

# **K** COUPLER REPLACEMENT GUIDE

## K-LINE BY LIONEL

**COUPLERS:** This K-Line By Lionel item is equipped with operating scale couplers for a more prototypical appearance. If you would like to replace the scale couplers with the operating O gauge couplers included in the box, the instructions are below. You may also choose to replace the rear coupler for operational reasons and leave the scale coupler on the front for a more prototypical appearance.

1. Turn engine over and remove the two screws holding on the rear scale coupler.
2. Attach the O gauge coupler to the inside set of holes.
3. Repeat for the front of the engine, if desired.

**O GAUGE COUPLER**

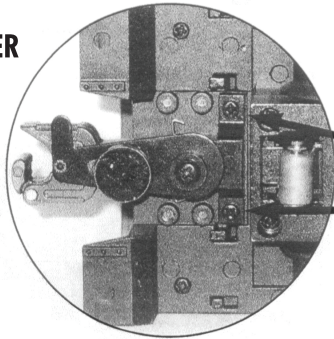

**COUPLER SCREWS**

**SCALE COUPLER**

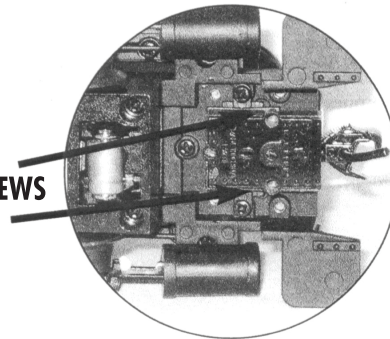

---

## Limited Warranty/Lionel Service

**T**his Lionel product, including all mechanical and electrical components, moving parts, motors and structural components, except for light bulbs, is warranted to the original consumer-purchaser, for **one year** against original defects in materials or workmanship when purchased through an authorized Lionel merchant.

This warranty does NOT cover normal wear and tear, light bulbs, defects appearing in the course of commercial use, or damage resulting from abuse or misuse of the product by the purchaser. Transfer of this product by the original consumer-purchaser to another person voids this warranty. Modification of this product voids this warranty.

Any warranted product which is defective in original materials or workmanship and is delivered by the original consumer-purchaser to Lionel L.L.C. or an authorized Lionel L.L.C. Service Center, together with proof of original purchase will, at the option of Lionel L.L.C., be repaired or replaced, without charge for parts or labor. In the event the defective product cannot be repaired, and a replacement is not available, a refund of the original purchase price will be granted. Any products on which warranty service is sought must be sent freight or postage prepaid, as transportation and shipping charges are not covered by the warranty.

### **In no event shall Lionel L.L.C. be liable for incidental or consequential damages.**

Some states do not allow the exclusion or limitation of incidental or consequential damages, so the above exclusion may not apply to you.

This limited warranty gives you specific legal rights, and you may have other rights which vary from state to state.

### **Instructions for Obtaining Service**

If service for this Lionel L.L.C. product is required, bring the item, along with your dated sales receipt and completed warranty information to the nearest Authorized Lionel Service Center. Your nearest Lionel Service Center can be found by calling 1-800-4-Lionel, or by accessing our Website at [www.lionel.com](http://www.lionel.com).

If you prefer to send your product back to Lionel L.L.C. for repair in Michigan, you must first call 586-949-4100 or FAX 586-949-5429, or write to Customer Service, P.O. Box 748, New Baltimore, MI 48047-0748, stating what the item is, when it was purchased and what seems to be the problem. You will be sent a return authorization letter and label to ensure your merchandise will be properly handled upon receipt.

Once you have received your return authorization and label, make sure that the item is packed to prevent damage during shipping and handling. We suggest that you use the product's original packaging. This shipment must be prepaid and we recommend that it be insured.

Please make sure you have followed all of the above instructions carefully before returning any merchandise for service. You may choose to have your product repaired by one of our Authorized Lionel Service Centers after its warranty has expired. A reasonable service fee will be charged.

### **Warranty Information**

Please complete the information below and keep it, along with your dated sales receipt. You must present this and your dated sales receipt when requesting warranty service.

Name \_\_\_\_\_

Address \_\_\_\_\_

Place of Purchase \_\_\_\_\_

Date of Purchase \_\_\_\_\_

Product Number \_\_\_\_\_

Product Description \_\_\_\_\_



© 2008 LIONEL L.L.C., CHESTERFIELD, MI 48051-2495  
UNITED STATES OF AMERICA  
PRINTED IN CHINA