

RF 1527 Learning Code Remote Control System

05/03/21

Introduction and General Description

This document describes the basic capability of a family of RF remote control boards that have been developed specifically for model train automation.

The remote control modules encompass both the transmit functions and receive functions. All of the units are based on off the shelf 433hz 1527 Learning Code transmit and receive modules with added circuitry to adapt them to the model train environment.

Transmitters

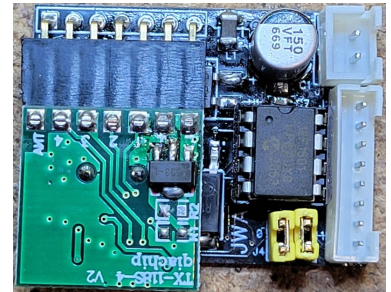

Two transmitter options are offered. The first is the familiar 4-button handheld key-fob controller. The second option is a 4-channel discrete input triggered board for permanent installation into locomotives, rolling stock, layout accessories, or lighting automation.

Receivers

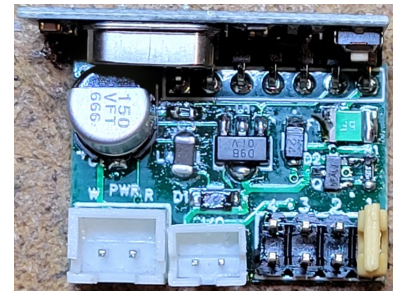
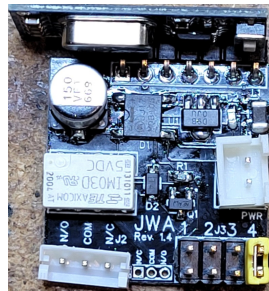
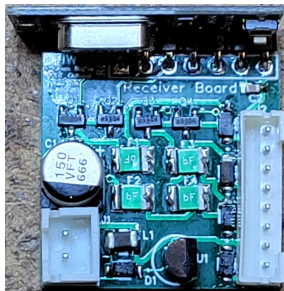
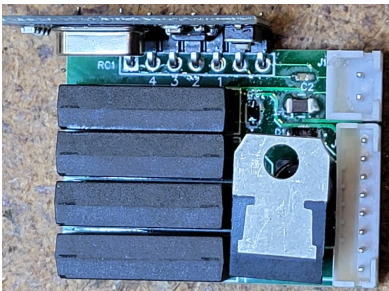

Four receiver board options are offered, a 4 channel reed relay based board, a 4 channel FET switch based board, 1 channel high current relay based board, and a 1 channel FET switch based board.

1527 Learning Code Receiver Programming

The receiver module used for all the receiver boards must be programmed to pair with the transmitter or transmitters you would like to use in conjunction with the specific receiver. The program description below details the pairing procedure for various receiver options.

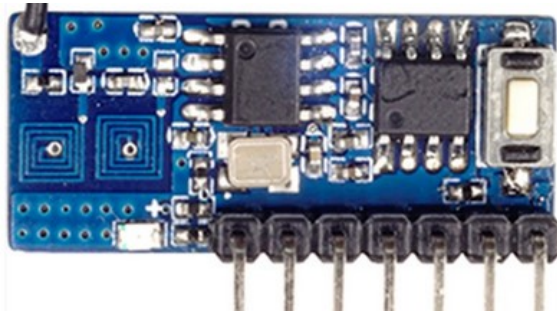

Figure 1: 433mhz 4-channel 1527 Learning Code Receiver

On the receiver is a small pushbutton used to do the transmitter/receiver pairing function. This button is referred to as the learning key in the following descriptions. Note a couple seconds of delay is needed between the delete existing data step and entering learning mode to program a new remote.

1. Delete existing data: Press learning key 8 times quickly. The receiver LED flashes 7 times.
2. Enter learning Mode: press learning key (on the receiver once, twice, or three times (see below). LED turns on: learning mode is active.
3. Pair Transmitter with remote: Press any button of the keyfob remote. For transmitter board, trigger any channel. LED indicator flashes three times if the learning process is successfully completed.
4. Test: The receiver board can be controlled by the remote control transmitter used in the above steps.

More transmitters with different IDs can be learned and stored additionally, starting with step 2 above.

You can also mix the modes for different paired transmitters. That means you could pair one receiver in momentary mode and another one in toggle mode, and finally a third receiver in interlocked mode. This would result in the receiver having different behavior based on which remote was triggering the action.

Button usage (sets mode and starts pairing process)

1. Press once (on the receiver): momentary mode (receiver output is only active until transmitter signal ceases)
2. Press twice (on the receiver) : self-Lock Mode (For each transmission, channel is toggled on or off)
3. Press three times (on the receiver): interlocked mode (selected channel is set active; all other channels are set inactive)

For more information or product support, contact: remotecontrol@will-enterprises.com

4-Channel Transmitter Board Connections and Configuration

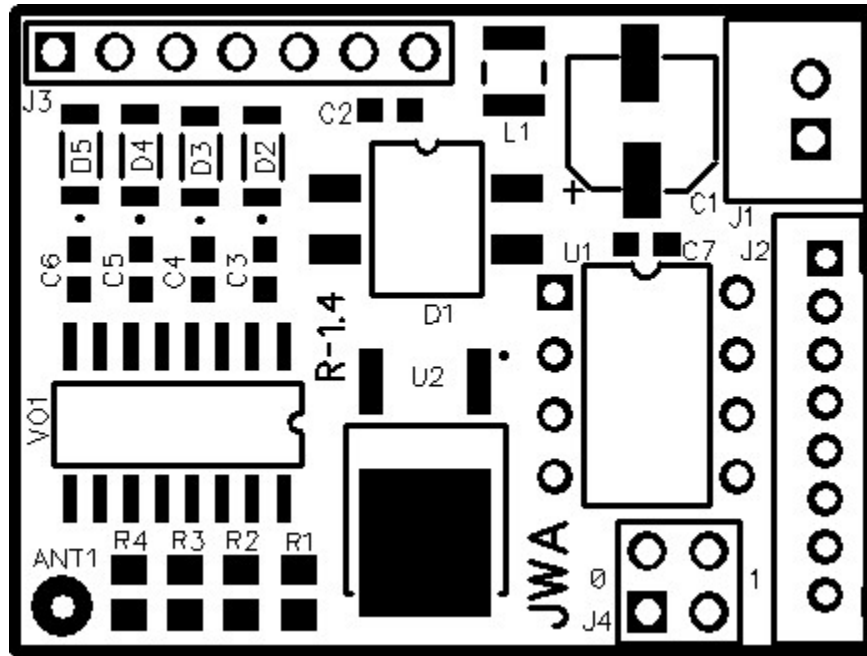

Figure 2: 4-channel Transmitter External Connections

For the following tables, refer to Figure 1 for the connector and pin locations. Note that the black square denotes pin 1 of a connector or jumper field.

J1 is the input power connection to the transmitter module. This input can be from 8 volts to 18 volts AC or DC of any polarity. Voltage in excess of 18 volts will damage the module. The module consumes from around 20 to 50 milliamps, depending on the specific inputs and transmission activity.

Pin	Description of Function
1	Power Connection (polarity not significant) [SQUARE PIN]
2	Power Connection (polarity not significant)

Table 1: J1 - Board Power, 8V to 18V AC or DC

J2 is the direct connection channel triggers for each of the four transmit channels. Note that each channel trigger input is two wires, and the pairs are numbered from one to four. This is because each channel is independently optically isolated from all other channels and any other board connections. This allows connection to any trigger voltage source without regard to common grounds or other electrical cross-connections. Any voltage between 2 volts and 18 volts AC or DC will trigger the channel. Input trigger current ranges from about 1 milliamp at 2V input voltage to about 16 milliamps at an 18V input voltage.

Note that exceeding 18 volts on any input may damage the transmitter module.

Pin	Description of Function
1	#1 Channel Trigger A (2 to 18V, AC or DC) [SQUARE PIN]
2	#1 Channel Trigger B (2 to 18V, AC or DC)
3	#2 Channel Trigger A (2 to 18V, AC or DC)
4	#2 Channel Trigger B (2 to 18V, AC or DC)
5	#3 Channel Trigger A (2 to 18V, AC or DC)
6	#3 Channel Trigger B (2 to 18V, AC or DC)
7	#4 Channel Trigger A (2 to 18V, AC or DC)
8	#4 Channel Trigger B (2 to 18V, AC or DC)

Table 2: J2 – Transmit Channel Trigger Inputs

J4 is the configuration jumper field. The first two channels of the transmit board have a microprocessor controlled configuration option and can be jumpered for multiple output options. The last two channels on the transmit board operate in pass-thru mode all of the time, the input signal is directly reflected in the output transmission.

The configuration option for the first channels allows use of trigger signals with characteristics that otherwise wouldn't be suitable for triggering the channel. Primarily, those characteristics would be a continuous signal that would cause continuous transmission thus blocking any other 433mhz transmission for other controllers transmitters or keyfobs in the same location.

1-2	3-4	Channel #1 & #2 Operation For The Jumpering Option Selected
0	0	Pass-thru: Output active as long as input trigger active.
0	1	Leading edge momentary: Output active for 100ms on trigger leading edge.
1	0	Leading/trailing edge momentary: Output active for 100ms on trigger leading edge, again active for 100ms on trigger trailing edge.
1	1	Two channel interlock: Output active on channel #1 for 100ms on trigger leading edge, output active on channel #2 for 100ms on trigger trailing edge. In this mode, any channel #2 input is ignored by the transmitter processor.

Table 3: J4 – Channel Configuration Options

The configuration options for channels #1 & #2 above work in conjunction with the 1527 receiver configuration options. This offers a wide variety of operating flexibility. Also, the short transmissions for most of the operating modes of the channels allow the use of multiple transmitters and receivers with minimal issues of RF channel conflicts. Note that continuous transmission from any transmitter will block the use of additional separate transmitters or keyfobs to access other receivers. Configuring the transmitter for short control transmissions avoids this potentially serious operational issue if using multiple transmitters, and is a key design element of the transmitter board.

One Channel FET Receiver Board

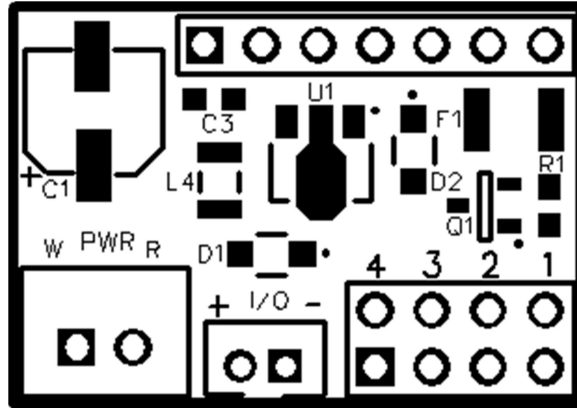

Figure 3: 1-channel FET Receiver External Connections

For the following tables, refer to Figure 2 for the connector and pin locations. Note that the black square denotes pin 1 of a connector or jumper field.

J1 is the input power connection to the FET receiver module. This input can be from 8 volts to 18 volts AC or DC of any polarity. Voltage in excess of 18 volts will damage the module. The module consumes from around 10 to 20 milliamps, depending on the any RF transmission activity.

Pin	Description of Function
1	Power Connection (Frame common, negative connection for DC) [SQUARE PIN]
2	Power Connection ((Center track, positive connection for DC))

Table 4: J1 - Board Power, 8V to 18V AC or DC

J2 is the output connection from the receiver module for the external load. Typically, for most applications, this will be one side of the load with the other side of the load going to the high side of the load power supply. Note that this board is rated at 200ma with a surge to around 500ma.

Pin	Description of Function
1	Output control FET drain (connect to power common)
2	Switched load negative lead.

Table 5: J2 – Output Connections to Load

J3 is the channel selection jumper field. One and only one of these should be jumpered to select the receiving channel for this receiver module.

Pin	Description of Function
1	Channel #4 Select
2	Channel #3 Select
3	Channel #2 Select
4	Channel #1 Select

Table 6: J3 – Channel selection

One Channel Relay Receiver Board

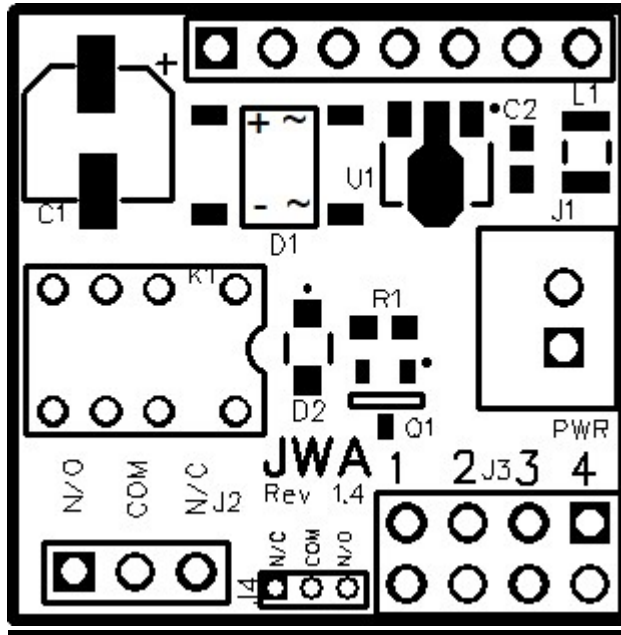

Figure 4: 1-channel Relay Receiver External Connections

For the following tables, refer to Figure 3 for the connector and pin locations. Note that the black square denotes pin 1 of a connector or jumper field.

J1 is the input power connection to the receiver module. This input can be from 8 volts to 18 volts AC or DC of any polarity. Voltage in excess of 18 volts will damage the module. The module consumes from around 10 to 40 milliamps, depending on the specific inputs and transmission activity.

Pin	Description of Function
1	Power Connection (polarity not significant) [SQUARE PIN]
2	Power Connection (polarity not significant)

Table 7: J1 - Board Power, 8V to 18V AC or DC

J2 is the output connection from the receiver module for the external load. .

Pin	Description of Function
1	N/C Relay Contact
2	COM Relay Contact
3	N/O Relay Contact

Table 8: J2 – Relay Contacts for Output Loads

J3 is the channel selection jumper field. One and only one of these should be jumpered to select the receiving channel for this receiver module.

<u>Pin</u>	<u>Description of Function</u>
1	Channel #4 Select
2	Channel #3 Select
3	Channel #2 Select
4	Channel #1 Select

Table 9: J3 – Channel selection

J4 is a secondary output connection from the receiver module for external loads. This is a second set of relay contacts provided for an optional additional isolated circuit.

<u>Pin</u>	<u>Description of Function</u>
1	N/C Relay Contact
2	COM Relay Contact
3	N/O Relay Contact

Table 10: J4 – Secondary Relay Contacts for Output Loads

Four Channel Relay Receiver Board

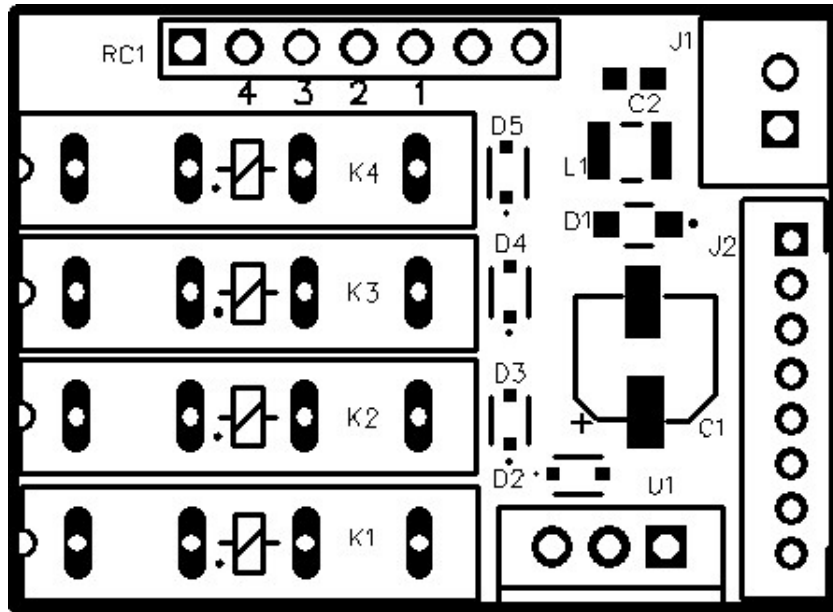

Figure 5: 4-channel Relay Receiver External Connections

For the following tables, refer to Figure 4 for the connector and pin locations. Note that the black square denotes pin 1 of a connector or jumper field.

J1 is the input power connection to the receiver module. This input can be from 8 volts to 18 volts AC or DC. Voltage in excess of 18 volts will damage the module. The module consumes from around 20 to 50 milliamps, depending on the specific inputs and transmission activity.

Pin	Description of Function
1	Power Connection (AC or Positive DC) [SQUARE PIN]
2	Power Connection (AC or Negative DC)

Table 11: J1 - Board Power, 8V to 18V AC or DC

J2 is the output connection from the receiver module for the external load. The relays on the 4-channel board are rated at 0.5 amp maximum load.

Pin	Description of Function
1	Relay contact Channel #1
2	Relay contact Channel #1
3	Relay contact Channel #2
4	Relay contact Channel #2
5	Relay contact Channel #3
6	Relay contact Channel #3
7	Relay contact Channel #4
8	Relay contact Channel #4

Table 12: J2 – Relay Contacts for Output Loads

Four Channel FET Receiver Board

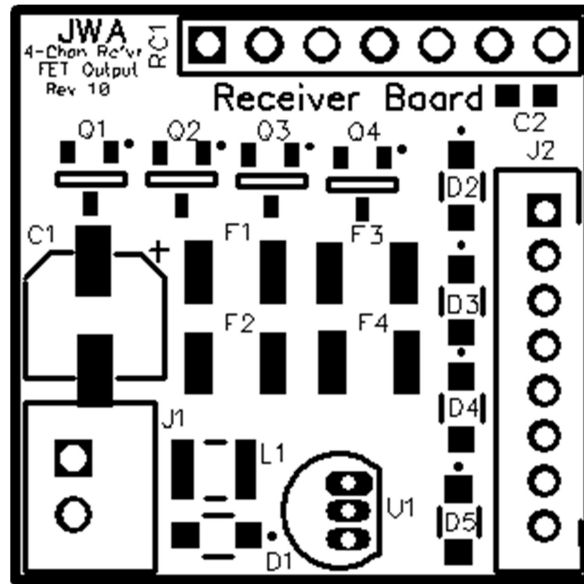

Figure 6: 4-channel FET Receiver External Connections

For the following tables, refer to Figure 4 for the connector and pin locations. Note that the black square denotes pin 1 of a connector or jumper field.

J1 is the input power connection to the receiver module. This input can be from 8 volts to 18 volts AC or DC. Voltage in excess of 18 volts will damage the module. The module consumes from around 10 to 20 milliamps, depending on the specific inputs and transmission activity.

Pin	Description of Function
1	Power Connection (AC or Positive DC) [SQUARE PIN]
2	Power Connection (AC or Negative DC) (Common for switched outputs)

Table 13: J1 - Board Power, 8V to 18V AC or DC

J2 is the output connection from the receiver module for the external load. The relays on the 4-channel board are rated at 0.5 amp maximum load.

Pin	Description of Function
1	Positive Power for Load (Connected to J1, pin-1)
2	Channel 4 Switched Open Drain to Common
3	Positive Power for Load (Connected to J1, pin-1)
4	Channel 3 Switched Open Drain to Common
5	Positive Power for Load (Connected to J1, pin-1)
6	Channel 2 Switched Open Drain to Common
7	Positive Power for Load (Connected to J1, pin-1)
8	Channel 1 Switched Open Drain to Common

Table 14: J2 – FET Connections for Output Loads