

MP3 Universal Sound Module

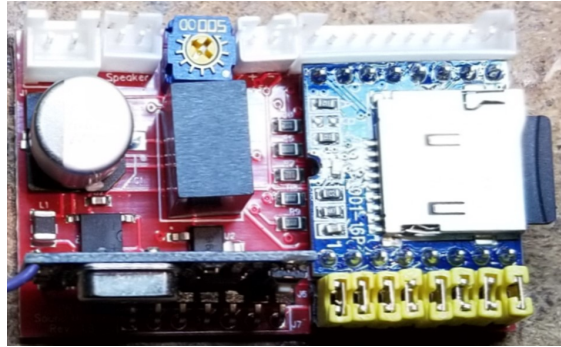

Figure 1: MP3 Universal Sound Module

1. Description

The **MP3 Universal Sound Module** is an electronic module that provides up to five separate selectable output sound tracks. Sound tracks are user configurable and are recorded as MP3 files on a Micro SD card. These output sound clips are individually playable using the RF remote key fob or the discrete optically isolated inputs to the module. Input trigger sources can be mixed and used in conjunction with each other, some triggered by the RF key fob and some by the discrete module connections. The sound tracks can be of any length, the supplied one gigabyte Micro-SD card has a storage capacity of between 80 and 100 hours of MP3 sound. The sound module output is a 3 watt 8 ohm amplifier capable of driving any common 8 ohm speaker from 2 to 5 watt capacity. An on-board volume control is provided. RF operation is provided by a 4-channel long range 1527 learning code superhet receiver. The MP3 Universal Sound Module circuit board is 2" x 1.25", with an overall height is approximately 5/8".

The total package includes the MP3 Universal Sound Module, matching 4-channel 1527 LC key fob transmitter, 1GB micro-SD card, USB micro-SD reader/writer, and all necessary connection cables.

Input discrete sound triggers can be any voltage from 2V to 18V AC or DC. Each discrete input is electrically isolated from all other discrete inputs. There are no restrictions on how the trigger is derived as long as it is within the voltage specifications. **See NOTE with J6 Input Selection Jumpers before connection!**

The MP3 files can be formatted using a variety of software applications. A popular and very capable free audio application for this use is the excellent Audacity sound editor. (<https://www.audacityteam.org/>).

2. Sound Module Board Connections

Figure 2 denotes the locations of the connectors and jumper blocks on the Universal Sound Module board. Each of the connections is further detailed in the following tables.

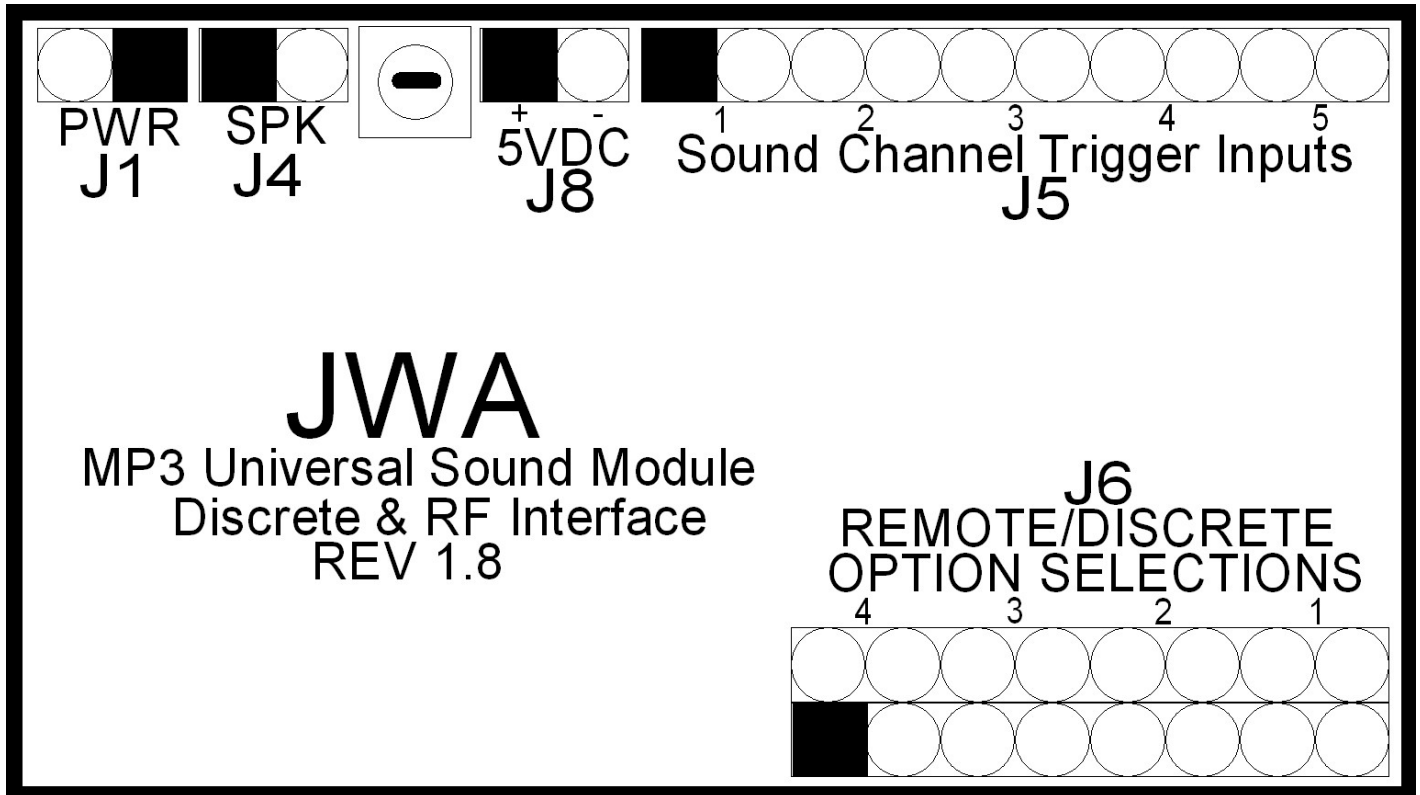

Figure 2: Sound Module External Connection Graphic

For the following tables, refer to Figure 2 for the connector and pin locations. Note that the black square denotes pin 1 of a connector or jumper field.

J1 is the input power connection to the sound module. This input can be from 8 volts to 18 volts AC or DC. Voltage in excess of 18 volts will likely damage the module. Connection polarity is not significant, for DC either polarity will work. The module consumes from 40 to 100 milliamps when audio is active, depending on the input voltage, audio content, and the volume setting. Standby power consumption is from 10-25 milliamps, again based on the above factors.

<u>Pin</u>	<u>Description of Function</u>
1	Power Connection (polarity not significant) [SQUARE PIN]
2	Power Connection (polarity not significant)

Table 1: J1 - Board Power, 8V to 18V AC or DC

J4 is the speaker connection. The speaker impedance should be 8 ohms, and the speaker should be rated between 2 watts and 5 watts. The connection polarity is not significant and will work with either polarity. Two 4 ohm speakers in series or two 16 ohm speakers in parallel can also be used if multiple speaker operation is desired.

Pin	Description of Function
1	Speaker Connection #1
2	Speaker Connection #2

Table 2: J4 – 8 Ohm Speaker Output

J5 is the direct connection channel triggers for each of the five playable audio sound clips. Note that each channel trigger input is two wires, and the pairs are numbered from one to five. This is because each channel is independently optically isolated from all other channels and any other board connections. This allows connection to any trigger voltage source without regard to common grounds or other electrical cross-connections. Any voltage between 2 volts and 18 volts AC or DC will trigger the channel. *Note that exceeding 18 volts may damage the sound module.*

Pin	Description of Function
1	#1 Channel Trigger A (2 to 18V, AC or DC) [SQUARE PIN]
2	#1 Channel Trigger B (2 to 18V, AC or DC)
3	#2 Channel Trigger A (2 to 18V, AC or DC)
4	#2 Channel Trigger B (2 to 18V, AC or DC)
5	#3 Channel Trigger A (2 to 18V, AC or DC)
6	#3 Channel Trigger B (2 to 18V, AC or DC)
7	#4 Channel Trigger A (2 to 18V, AC or DC)
8	#4 Channel Trigger B (2 to 18V, AC or DC)
9	#5 Channel Trigger A (2 to 18V, AC or DC)
10	#5 Channel Trigger B (2 to 18V, AC or DC)

Table 3: J5 – Sound Channel Trigger Inputs

J6 is the trigger source selection jumpers to select between RF remote or direct connections sound triggering. The module comes with all jumpers installed to enable use with the RF key fob remote for the first four channels. To use the direct connection for any of the first four sound triggers, you must remove the two RF selection jumpers associated with the channel in question. The fifth sound channel is only available as a direct connection; it has no RF selection jumper set as the RF receiver is a 4-channel device. Refer to *Figure 2: Sound Module External Connection Graphic* for the location of the jumper pairs for the respective channels.

NOTE: To use the opto-isolated direct connection for channels #1 through #4, you MUST remove the source selection jumpers corresponding to that channel from the J6 jumper field. Failure to remove these jumpers will damage the RF receiver and likely render it inoperative!

<u>Pin</u>	<u>Description of Function</u>
1	#4 RF Remote Input Channel Select - A [SQUARE PIN]
2	#4 RF Remote Input Channel Select – B
3	#3 RF Remote Input Channel Select – A
4	#3 RF Remote Input Channel Select – B
5	#2 RF Remote Input Channel Select – A
6	#2 RF Remote Input Channel Select – B
7	#1 RF Remote Input Channel Select – A
8	#1 RF Remote Input Channel Select - B

Table 4: J6 – Remote / External Jumper Selection (configured in pairs)

J8 is an internally supplied 5V power source. This is only for use for specific add-on board features; it must never be connected to an outside circuit that shares any connection with the input power source.

NOTE: Improper use of the internal 5V supply will destroy the board! Only connect this output as directed in this document or documentation for add-on boards!

<u>Pin</u>	<u>Description of Function</u>
1	+5VDC Output [SQUARE PIN]
2	-5VDC Output

Table 5: J8 – 5V DC Output (200ma max)

3. MP3 micro-SD File Format Considerations

Up to five MP3 format sound files are written to the micro-SD, corresponding to the five possible sound channels. These files should be monophonic format files, not stereo format files as the player only plays a single channel. The files are all written to the root folder on the micro-SD, the naming is non-critical, as long as it's a valid file name.

The proper technique for writing your sound file to the micro-SD card is to start with a completely blank micro-SD. This is because order in which the files are written to the micro-SD card will determine their mapping to the sound channels. The first file to be written to the card will be played by the channel #1, the second one by #2, etc. This is regardless of what their file names are. This behavior is due to the way the MP3 player module processes the micro-SD sound files. A recommendation to keep things visually straight is to adopt a naming convention as follows for the five sound files.

- 1-First Sound File
- 2-Second Sound File
- ...

You still have to write them in order, but when you look at the file list, it'll be easier to see which sound file is associated with which trigger channel.

For more information or product support, contact: mp3sound@will-enterprises.com

4. Typical Application Examples

For use with only the RF key fob, the connections are simply the power and the speaker. No other external connections are required for this configuration. For this configuration, all the jumpers for J6 are installed to enable all four RF channel inputs.

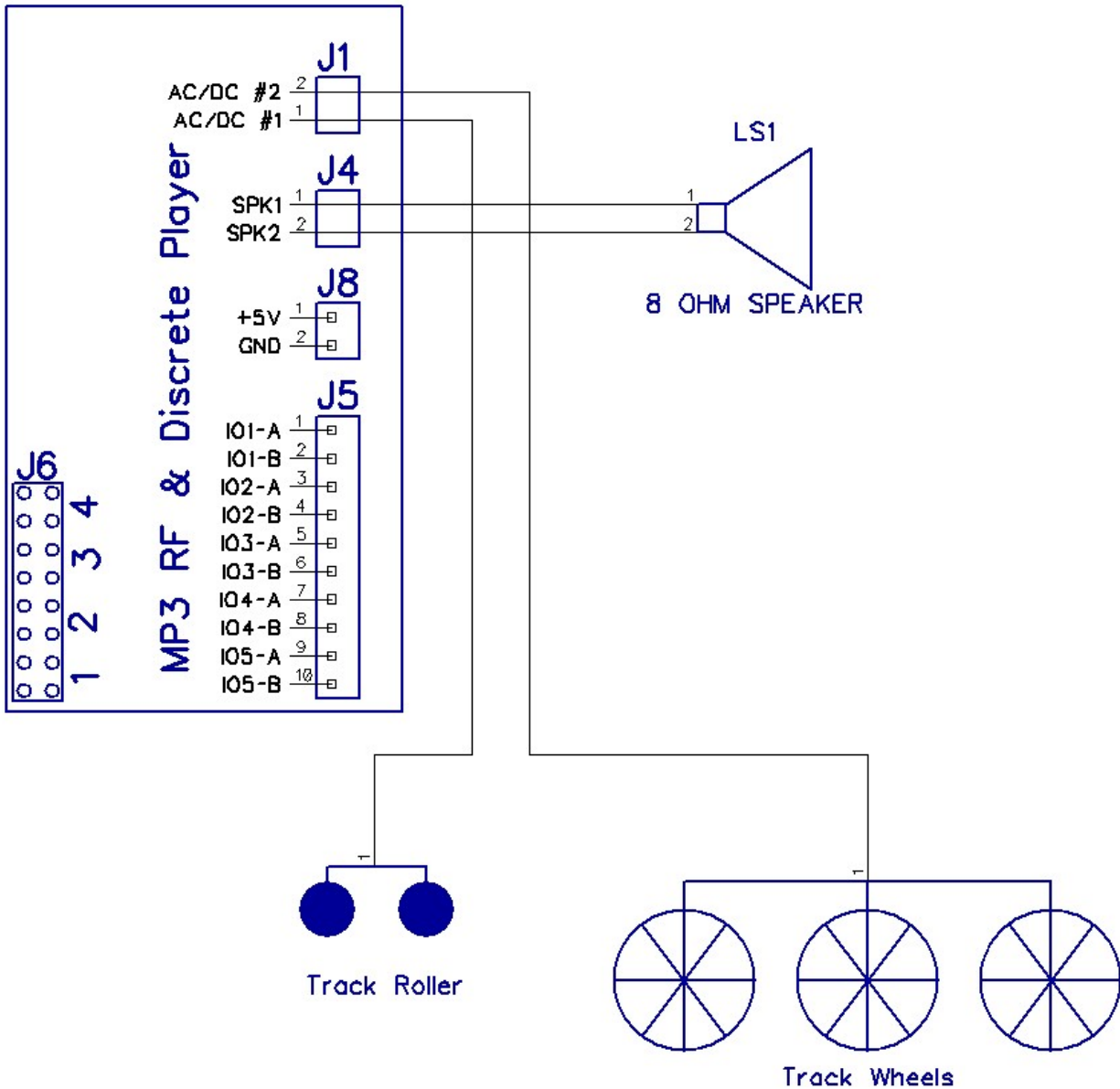

Figure 3: RF Remote Only Wiring Diagram

For mixed inputs from both the RF key fob and the discrete input connections, J5 is used to connect the discrete inputs. Be sure to also configure the Remote/External jumpers properly to avoid damage to the Receiver board. The example below only uses discrete input #5, thus doesn't require you to remove any jumpers from J6.

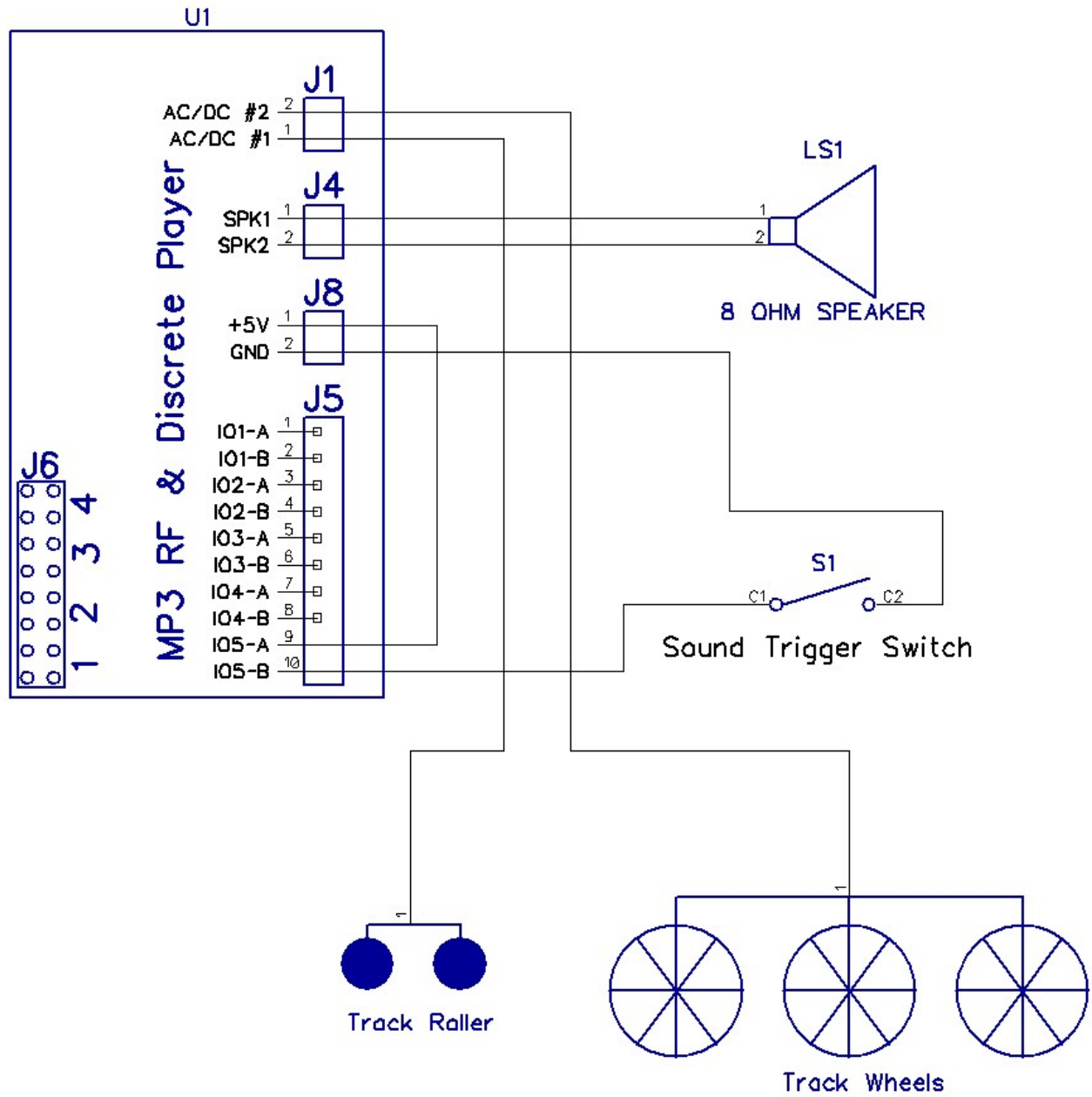

Figure 4: Mixed Connection Application

This example adds sound to a freight car. The freight car has provisions for sounds when stopped as well as changing sounds as the car moves faster to simulate actual prototype sounds. An add-on Wheel Speed Sensor board is used to sense the actual car speed and trigger the appropriate sound track for the current status of the car. For more information on the Wheel Speed Sensor, please consult the separate document for that board. Note that channel 1 of the trigger inputs is left open. This can be jumpered to use the RF key fob supplied with the MP3 sound board for a remote controlled sound using the key fob. Typical uses might be a loading or unloading scenario while the car is stopped.

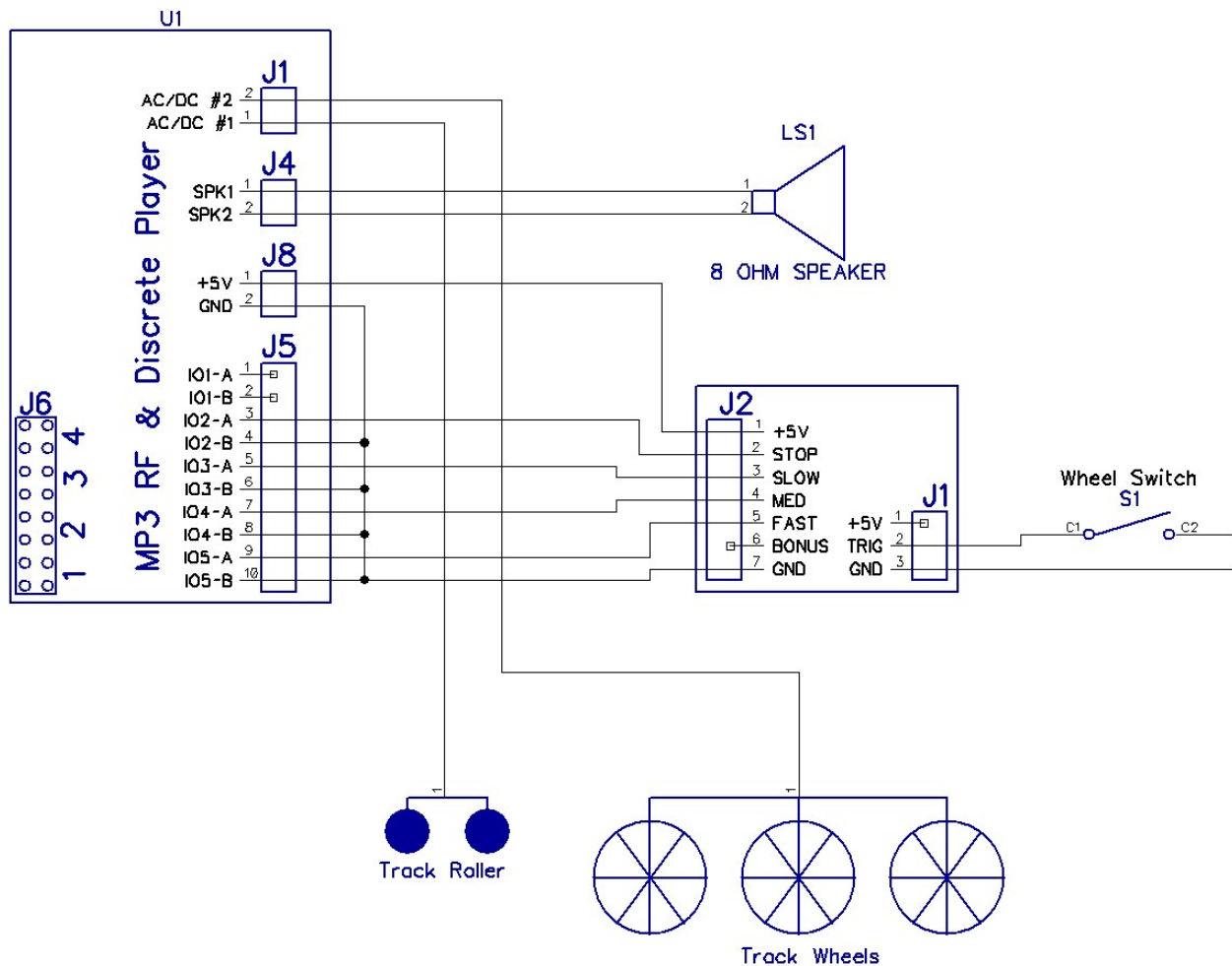

Figure 5: Typical Freight Car Application