

70-5121-250
3/05

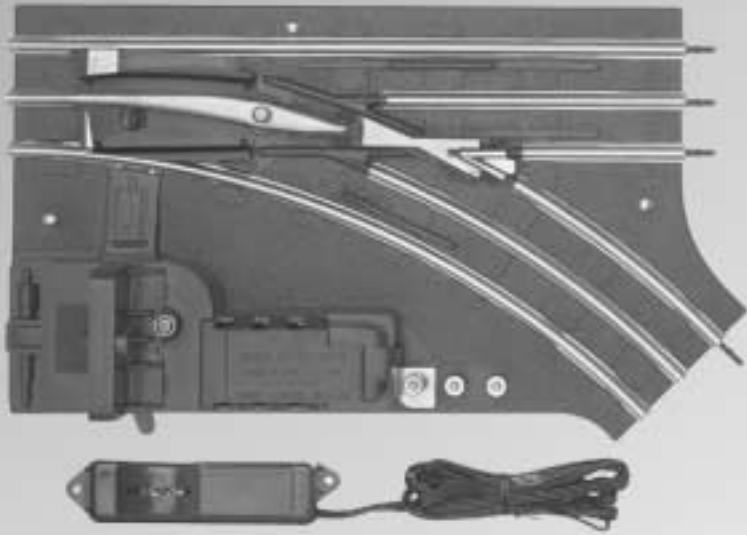

Lionel
0-27 Gauge 27" Path
Remote-Control Switch
Owner's Manual

Congratulations on your purchase of the Lionel O-27 Gauge 27" Path Remote-Control Switch! This non-derailing switch is operated by a remote control or a lever on the switch motor.

Table of Contents

Using your 27" Path Switch on your layout	3
Installing the switches	3
Connecting the switch controller	4
Throwing the switch	4
Operating the switch in the TrainMaster Command Control environment	5
Modifying the O-27 gauge switch for use with a fixed voltage power supply	5
Connecting the switch to an Accessory Switch Controller (ASC)	6
Connecting the switch to an SC-2 Switch Accessory Controller	7
Passing through a switch in the wrong direction	7
Limited Warranty/Lionel Service	8

The following Lionel marks may be used throughout this instruction manual and are protected under law. All rights reserved.

Lionel®, *TrainMaster®*, *Odyssey®*, *RailSounds®*, *CrewTalk™*, *TowerCom™*, *DynaChuff™*, *StationSounds™*, *Pullmor®*, *ElectroCoupler™*, *Magne-Traction®*, *CAB-1® Remote Controller*, *PowerMaster®*, *Lionel ZW®*, *ZW®*, *PowerHouse®*, *TMCC®*, *Lionelville™*, *Lockon®*, *Wireless Tether™*, *LionMaster®*, *FatBoy™*, *American Flyer®*, *TrainSounds™*

Using your 27" Path Switch on your layout

With the addition of track switches, you can vary the route taken by your trains. For example, you can maneuver your train into a different loop or send it to a siding. See Figure 1.

Keep in mind that most layouts use right- and left-hand switches together so that the trains can get back to the mainline without backing up. Refer to the first two layouts shown in Figure 1.

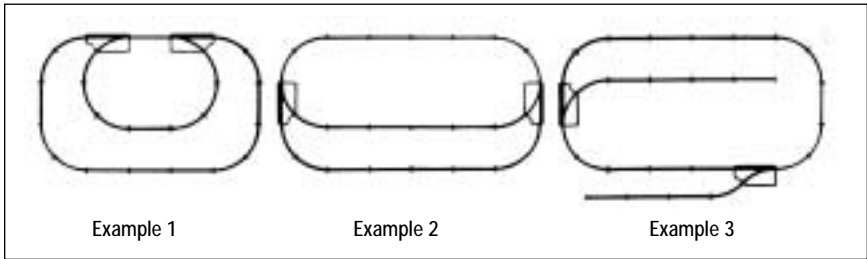

Figure 1. Layout examples

Installing the switches

Join the track sections together by inserting the track pins into the openings at the end of the switch rails. For good electrical contact, pins must be completely inserted so that the track joints are tightly fitted together.

If you find that the switch insulator pins interfere with the pins in the regular track sections, carefully remove the **metal track pins** with a pair of pliers. Leave the **switch insulator pins** in place.

Note! Do not remove the insulating pins.

The switch mechanism draws its power from the track, so no additional power connections are necessary.

Connecting the switch controller

The switch controller is connected to the switch by three wires. Connect the ribbed trace wire to the thumbscrew terminal closest to the switch box. The middle wire should be connected to the middle terminal, and the remaining wire is attached to the remaining terminal. Refer to Figure 2.

Note! Reverse the two wires farthest from the switch motor to reverse the operation of the switch and the signal indicator.

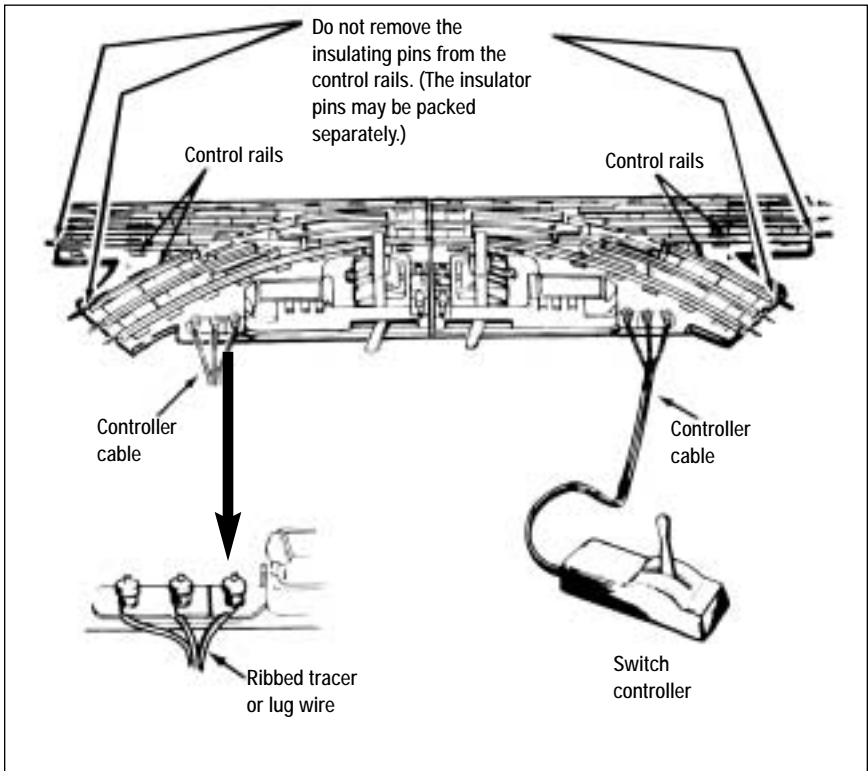

Figure 2. Controller connections

Throwing the switch

Manually slide the switch lever at the base of the switch or use the controller lever to throw the switch. The swivel rails, or "points", will snap over and the direction indicator will change.

Note! Because the switch is powered through the track, be sure that track power is set to 8 to 14 volts (AC) before you throw the switch with the separate controller.

Operating the switch in the TrainMaster Command Control environment

You may choose to operate your switch in the TrainMaster Command Control environment using an Accessory Switch Controller (available separately, 6-14182) or an SC-2 Switch and Accessory Controller (available separately, 6-22980).

Modifying 0-27 gauge switches for use with a fixed voltage power supply

O-27 gauge switches receive their power from variable track voltage. In order to operate this type of switch with a fixed voltage power source, you need to make the following modifications.

First, take the top cover off of the switch by removing the screw from the top of the motor housing. This will expose the double coils. Next, find the two wires that are located at the center of the two coils. These wires are contained inside one piece of insulation. Gently pull on the insulation to expose the wires. Now, clip the two wires about 1/2" from the coils. Using electrical tape, wrap the wire ends that come up from the bottom of the switch. Use the heat from your soldering iron to remove 1/4" of the varnish insulation from the remaining wires, then twist the wires together. Using your soldering iron, put a small amount of solder on the ends of these wires and solder a jumper wire to them. Wrap this connection with electrical tape to keep it from coming in contact with the coil housing. The switch will operate best at 10-14 volts (AC).

Before you replace the switch cover, you may need to cut a notch (using a hobby knife) for the wire to come through. You may also route the wire through the holes used to vent any heat generated by the coils on top of the cover. Replace the cover on the switch, then attach the jumper wire to a fixed voltage power source.

You will need to attach a ground wire from this separate power source to the outside rail of your track, or you can attach this ground wire to the "U" post on the track power supply. Connect the switch as discussed in the previous section.

Note! The separate power supply must be in phase with the track power supply for proper operation.

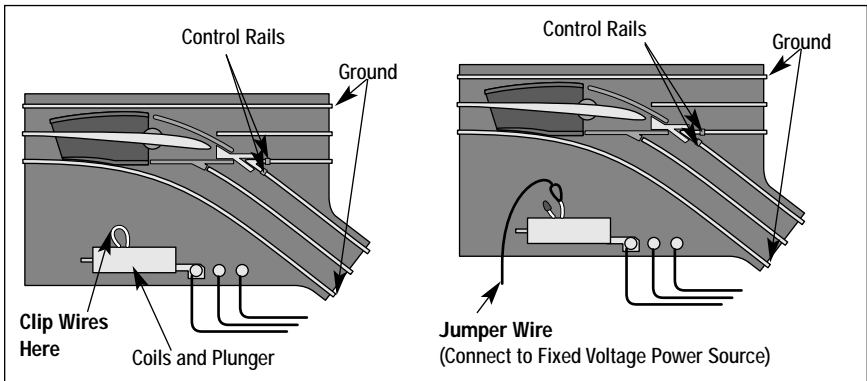

Figure 3. Wiring Lionel 0-27 gauge switches

Connecting the switch to an Accessory Switch Controller (ASC)

After modifying your switch (refer to the previous section), you may connect the switch to your Accessory Switch Controller (available separately, 6-14182). Connect the terminal closest to the switch box to the COM terminal on the ASC. Connect the middle switch terminal to a numbered O terminal on the ASC. Connect the remaining terminal to the corresponding T terminal on the ASC. Refer to Figure 4.

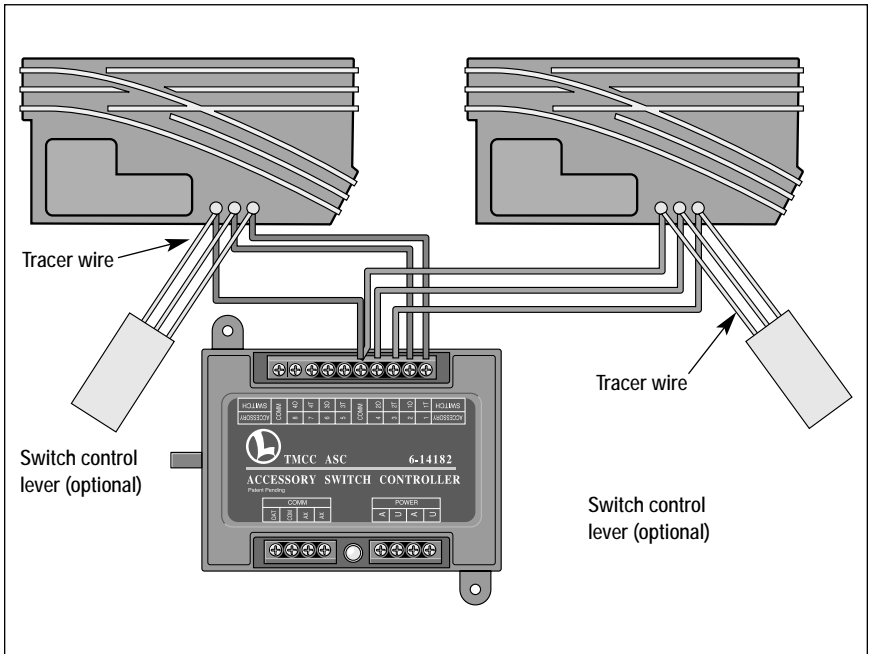

Figure 4. ASC connections

Connecting the switch to an SC-2 Switch Accessory Controller

After modifying your switch (refer to the previous section), you may connect the switch to your SC-2 Switch Accessory Controller (available separately, 6-22980). Connect the terminal closest to the switch box to the COM terminal on the SC-2. Connect the middle switch terminal to a numbered OUT terminal on the SC-2. Connect the remaining terminal to the corresponding THROUGH terminal on the SC-2. Refer to Figure 5.

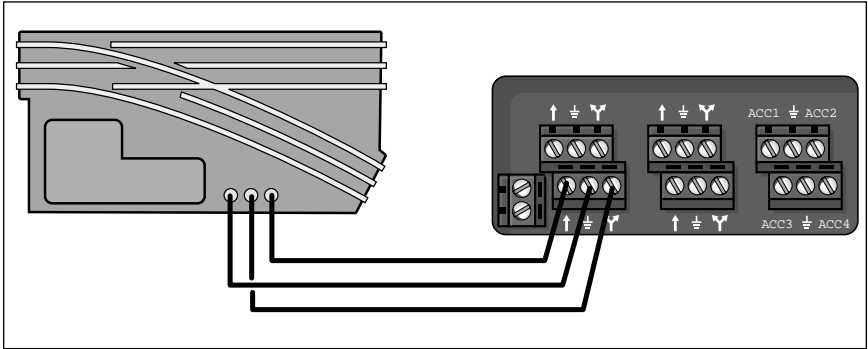

Figure 5. SC-2 connections

Passing through a switch in the wrong direction

Your switch is equipped with a “non-derailing” feature. When a train enters the “closed” branch of the switch, the wheels and axles complete an electrical circuit that causes the control arm to swing open. This feature allows your trains to pass though without a problem.

Note! Be sure to keep the insulating pins in the switch rails for this feature to function properly.

Caution! The “non-derailing” feature is activated as long as any part of the train is on the switch. Allowing your train to remain on the switch for an extended period of time will overheat and damage the switch.

Limited Warranty/Lionel Service

This Lionel product, including all mechanical and electrical components, moving parts, motors and structural components, except for light bulbs, is warranted to the original consumer-purchaser, for **one year** against original defects in materials or workmanship when purchased through an authorized Lionel merchant.

This warranty does NOT cover normal wear and tear, light bulbs, defects appearing in the course of commercial use, or damage resulting from abuse or misuse of the product by the purchaser. Transfer of this product by the original consumer-purchaser to another person voids this warranty. Modification of this product voids this warranty.

Any warranted product which is defective in original materials or workmanship and is delivered by the original consumer-purchaser to Lionel L.L.C. or an authorized Lionel L.L.C. Service Center, together with proof of original purchase will, at the option of Lionel L.L.C., be repaired or replaced, without charge for parts or labor. In the event the defective product cannot be repaired, and a replacement is not available, a refund of the original purchase price will be granted. Any products on which warranty service is sought must be sent freight or postage prepaid, as transportation and shipping charges are not covered by the warranty.

In no event shall Lionel L.L.C. be liable for incidental or consequential damages.

Some states do not allow the exclusion or limitation of incidental or consequential damages, so the above exclusion may not apply to you.

This limited warranty gives you specific legal rights, and you may have other rights which vary from state to state.

Instructions for Obtaining Service

If service for this Lionel L.L.C. product is required, bring the item, along with your dated sales receipt and completed warranty information to the nearest Authorized Lionel Service Center. Your nearest Lionel Service Center can be found by calling 1-800-4-Lionel, or by accessing our Website at www.lionel.com.

If you prefer to send your product back to Lionel L.L.C. for repair in Michigan, you must first call 586-949-4100 or FAX 586-949-5429, or write to Customer Service, P.O. Box 748, New Baltimore, MI 48047-0748, stating what the item is, when it was purchased and what seems to be the problem. You will be sent a return authorization letter and label to ensure your merchandise will be properly handled upon receipt.

Once you have received your return authorization and label, make sure that the item is packed to prevent damage during shipping and handling. We suggest that you use the product's original packaging. This shipment must be prepaid and we recommend that it be insured.

Please make sure you have followed all of the above instructions carefully before returning any merchandise for service. You may choose to have your product repaired by one of our Authorized Lionel Service Centers after its warranty has expired. A reasonable service fee will be charged.

Warranty Information

Please complete the information below and keep it, along with your dated sales receipt. You must present this and your dated sales receipt when requesting warranty service.

Name _____

Address _____

Place of Purchase _____

Date of Purchase _____

Product Number _____

Product Description _____



©2005 LIONEL L.L.C., CHESTERFIELD, MI 48051-2493
UNITED STATES OF AMERICA
PRINTED IN CHINA