



Lionel

FastTrack

Modular Railroad

Specification Manual

Ver 2.0

© Copyright 2012 by Lionel Collectors Club of America

Lionel®, Circle L Logo®, FasTrack®, and are registered trademarks of Lionel, LLC; LEGACY™ is a trademark of Lionel, LLC; All rights reserved.

Lionel FasTrack Modular Railroad

Specifications

Introduction

From the beginning, the Lionel FasTrack Modular Railroad has been a joint effort between Lionel L.L.C. and the Lionel Collectors Club of America. In February of 2012, the Lionel Collectors Club of America (LCCA) formed a committee to take on the task of designing standards for a FasTrack Module Layout System. Lionel was also enthusiastic about the prospects of a national FasTrack module specification and the committee was joined by three Lionel representatives.

The following specifications detail the work of the committee. Although this document details all the information necessary for the construction and wiring of the modules, we expect additions to be made to this manual, including additional photographs and layout suggestions.

An initial set of modules was built by TW TrainWorx and premiered at the LCCA Annual Convention in July of 2012. With tasks such as module construction, wiring, scenery and track laying, this is a great project to involve the entire family. And when completed, you'll have the opportunity to join with others and create a large layout, and finally the opportunity to run your trains using Lionel's Legacy Command Control System.

The system has been designed to allow a variety of uses. In addition to assembling a layout at an event where individuals gather with their modules, the modules can be included in a home layout and be easily removed to attend an event. The modules also provide a great way to assemble a home layout that can be easily rearranged or enlarged.

Those interested in participating in the Lionel FasTrack Modular Railroad system can do so in several ways:

- Build the module from scratch. Full details including plans and specifications are included in this manual. Those with the skill and equipment necessary can build their own modules from scratch. In order that your module mates with those by others, it is essential that dimensions be strictly adhered to.
- Build the module from a Lionel kit. Lionel is offering FasTrack Modular Railroad kits for the straight and both corner modules. Each kit will include all hardware, wood framing, electricals and two 5 inch sections of FasTrack used between adjoining modules. The corner modules also include a full size paper template. You supply the plywood top, the 2 x 2 legs and the track. These kits will be available through www.LionelStore.com.

- For those building the kit or from scratch, Lionel is also offering an approved No. 6-37150 Lionel FasTrack Modular Railroad Template. The plastic template will ensure precise placement of both track and rotolock latches on both sides of the module. It is a useful tool that can be used over and over again. The same template works for all four types of modules and is available in the Lionel online store - www.LionelStore.com.
- Fully assembled modules in a variety of styles from bare tables to fully decorated pieces built to your personal requests will be available from TW TrainWorx - www.twtrainworx.com.

Overview of Plans

Sheet 1 illustrates a top view of the straight module
 Sheet 2 shows an assembly view of the straight module
 Sheet 3 shows a top view of the full corner module
 Sheet 4 shows an assembly view of the full corner module
 Sheet 5 shows a top view of a straight module and two full corner modules
 Sheet 6 shows a top view of two reversible corner modules
 Sheet 7 shows an assembly view of the reversible corner module
 Sheet 8 shows details of the steel leg bracket
 Sheet 9 illustrates top view of the small radius module
 Sheet 10 illustrates an underside view of the small radius module
 Sheet 11 shows the module template
 Sheet 12 explains how to use the template

[A new section with track and module layout plans has been added to this manual. In this new section are plans that illustrate methods for incorporating O72 switches on straight modules. Also in this section are several suggested module layout plans in a variety of shapes. We expect this section to expand with additional plans for module setups.](#)

Materials Needed

Listed on the following pages are the contents of each of the kits. Those who wish to build a module, whether from a kit or from scratch will find the details for the parts necessary in these lists. Construction of the table frame is critical and it is strongly suggested that when placing the track and the rotolocks, all measurements be taken from the front of the module, rather than from both front and back. Whether building from scratch or from a kit, use of the FasTrack Module Template is recommended to ensure precise placement of the rotolock latches and the FasTrack.

Sources for some of the more difficult to find hardware are listed at the end of this manual.

Straight Module Kit
See drawing sheets 1,2 and 8

Quantity	Description
2	Pine framing 45 inches x 3 inches x 3/4 inch thick., rabbeted as shown in drawing sheet 1. The kits include clear, finger jointed pine which has been cut to size. This results in straight and relatively flat pieces.
2	3/4 inch birch plywood for the end pieces of the table frame, 28 1/2 inches by 2 1/2 inches. These are notched for the rotolocks as indicated in drawing sheet 1.
4	Wood biscuit joiners. These aid in precise assembly of the table rails in the kit.
4	#6 flat head wood screws 1 1/2 inches long - if biscuits are not used 8 are required
4	Steel leg brackets as per drawing sheet 8.
4	Hex head bolts for leg brackets 3/8-16 x 1 inch long
10	#8 Pan head screws 3/4 inch long to secure leg brackets and terminal strip
2	Rotolock sets (Each includes a male and female component) These are used to connect adjoining module tables.
1	Rotolock wrench
8	#10-24 flat head bolt 1 1/2 inches long to secure rotolocks
8	#10 washers
8	#10-24 Nylon insert locknuts
4	Leveling mount for legs w/1/4-20 thread
4	1/4-20 threaded inserts for bottom of legs
1	8 wire wiring harness
1	8 position terminal strip
4	Cable ties
2	1/2 inch cable clamp
2	1 inch cable clamp
4	#8 pan head screws 1/2 inch long used to secure cable clamps
23	#4D finishing nails - used to secure plywood top to frame
2	5 inch sections of FasTrack

Full Corner Module Kit
See drawing sheets 1, 3, 4, and 8

Quantity	Description
5	Pine framing 3 inches x 3/4 inch thick, cut at lengths and rabbeted as shown in drawing sheet 3. The kits include clear, finger jointed pine which has been cut to size. This results in straight and relatively flat pieces.
2	3/4 inch birch plywood for the end pieces of the table frame, 28 1/2 inches by 2 1/2 inches. These are notched for the rotolocks as indicated in drawing sheet 1.
7	Wood biscuit joiners. These aid in precise assembly of the table rails in the kit.
4	#6 flat head wood screws 1 1/2 inches long - if biscuits are not used 8 are required
4	Steel leg brackets as per drawing sheet 8.
4	Hex head bolts for leg brackets 3/8-16 x 1 inch long
10	#8 Pan head screws 3/4 inch long to secure leg brackets and terminal strip
2	Rotolock sets (Each includes a male and female component) These are used to connect adjoining module tables.
1	Rotolock wrench
8	#10-24 flat head bolt 1 1/2 inches long to secure rotolocks
8	#10 washers
8	#10-24 Nylon insert locknuts
4	Leveling mount for legs w/1/4-20 thread
4	1/4-20 threaded inserts for bottom of legs
1	8 wire wiring harness
1	8 position terminal strip
4	Cable ties
2	1/2 inch cable clamp
2	1 inch cable clamp
4	#8 pan head screws 1/2 inch long used to secure cable clamps
1	Full size paper template for table frame
20	#4D finishing nails - used to secure plywood top to frame
2	5 inch sections of FasTrack

Reversible Narrow Corner Module Kit
See drawing sheets 1, 6, 7, and 8

Quantity	Description
6	Pine framing 3 inches x 3/4 inch thick, cut at lengths and rabbeted as shown in drawing sheets 6 and 7. The kits include clear, finger jointed pine which has been cut to size. This results in straight and relatively flat pieces.
2	3/4 inch birch plywood for the end pieces of the table frame, 11 1/2 inches by 2 1/2 inches. These are notched the for rotolocks as indicated in drawing sheet 1.
8	Wood biscuit joiners. These aid in precise assembly of the table rails in the kit.
4	#6 flat head wood screws 1 1/2 inches long - if biscuits are not used 8 are required
4	Steel leg brackets as per drawing sheet 8.
4	Hex head bolts for leg brackets 3/8-16 x 1 inch long
10	#8 Pan head screws 3/4 inch long to secure leg brackets and terminal strip
1	Rotolock set (Includes a male and female component) These are used to connect adjoining module tables.
1	Rotolock wrench
4	#10-24 flat head bolt 1 1/2 inches long to secure rotolocks
4	#10 washers
4	#10-24 Nylon insert locknuts
4	Leveling mount for legs w/1/4-20 thread
4	1/4-20 threaded inserts for bottom of legs
1	8 wire wiring harness
1	8 position terminal strip
4	Cable ties
2	1/2 inch cable clamp
2	1 inch cable clamp
4	#8 pan head screws 1/2 inch long used to secure cable clamps
1	Full size paper template for table frame
17	#4D finishing nails - used to secure plywood top to frame
2	5 inch sections of FasTrack

Small Radius Corner Module Kit
See drawing sheets 1, 8, 9, and 10

Quantity	Description
5	Pine framing 3 inches x 3/4 inch thick, cut at lengths and rabbeted as shown in drawing sheet 3. The kits include clear, finger jointed pine which has been cut to size. This results in straight and relatively flat pieces.
2	3/4 inch birch plywood for the end pieces of the table frame, 28 1/2 inches by 2 1/2 inches. These are notched for the rotolocks as indicated in drawing sheet 1.
7	Wood biscuit joiners. These aid in precise assembly of the table rails in the kit.
4	#6 flat head wood screws 1 1/2 inches long - if biscuits are not used 8 are required
4	Steel leg brackets as per drawing sheet 8.
4	Hex head bolts for leg brackets 3/8-16 x 1 inch long
10	#8 Pan head screws 3/4 inch long to secure leg brackets and terminal strip
2	Rotolock sets (Each includes a male and female component) These are used to connect adjoining module tables.
1	Rotolock wrench
8	#10-24 flat head bolt 1 1/2 inches long to secure rotolocks
8	#10 washers
8	#10-24 Nylon insert locknuts
4	Leveling mount for legs w/1/4-20 thread
4	1/4-20 threaded inserts for bottom of legs
1	8 wire wiring harness
1	8 position terminal strip
4	Cable ties
2	1/2 inch cable clamp
2	1 inch cable clamp
4	#8 pan head screws 1/2 inch long used to secure cable clamps
1	Full size paper template for table frame
20	#4D finishing nails - used to secure plywood top to frame
2	5 inch sections of FasTrack

Module Assembly Notes

The plywood top and the legs are not included in the kits. The legs are 2 x 2s, which actually measure 1 1/2 inches square, and are easily available at most lumber supply stores. These should be cut to a length of 31 inches and leveler mounts installed at the bottom with threaded inserts (see sources below). In addition, you will need glue. We recommend the yellow carpenters glue. This glue is strong, dries quickly and is easily sanded once dry.

Begin by assembling the table frame sections. Once the frame is together, add the four leg brackets, one in each corner. These should be installed flush with the lower edge of the frame, allowing a view of the top of the leg when fully installed. The leg should be fully seated against the underside of the plywood top.

The plywood top sets within the rabbeted notch at the front and back edges of the table frame and is flush with the two ends. Due to the design of the table frame, the plywood top can be a bit smaller than exact size without effecting measurements made with the template. The template takes all measurements from the table frame not the plywood. ***It is important that the plywood not be cut larger than the correct size.*** Should the plywood extend beyond the table frame on either end, the module will not properly connect to another module.

Rotolock and Track Placement

An important aspect of any modular system is the ability to join adjacent modules together, while accurately maintaining track spacing between modules. This requires that both the rotolocks and the FasTrack be accurately positioned on the module. The photo below shows the male and female components of a rotolock. An installed male rotolock component can also be seen with the rotolock wrench in place and the rotolock in a partially locked position.

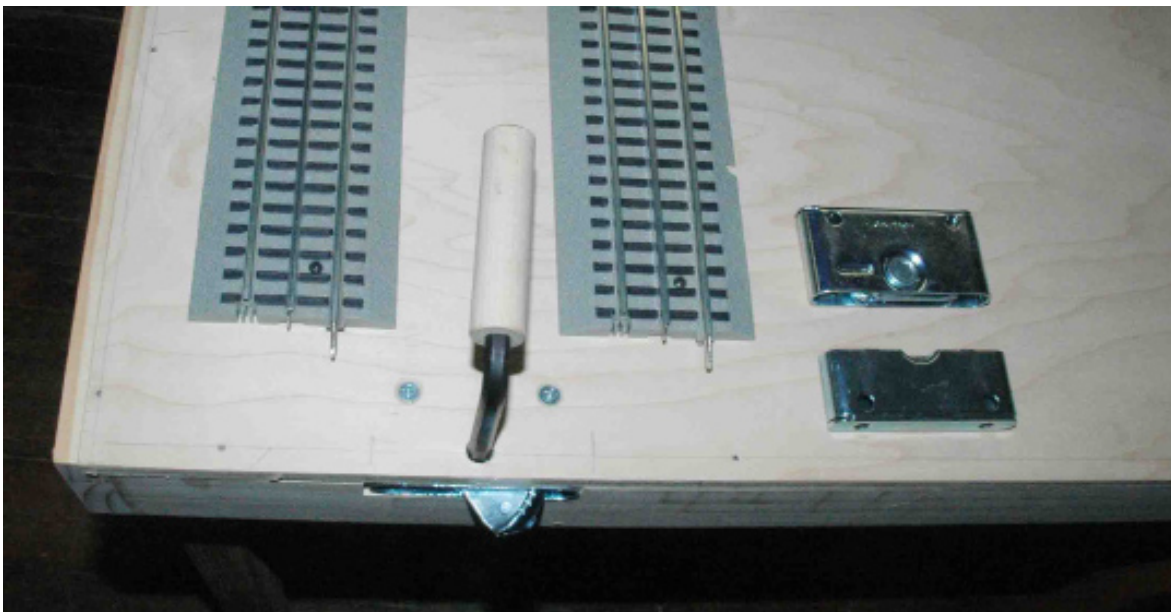

When making measurements to place the track and the rotolocks, be sure to make all measurements from the front edge. The front being the long edge nearest the track. In this way, any slight variation in top measurements will be compensated for. An easy and accurate way to accomplish this is to use the approved No. 6-37150 Lionel FasTrack Modular Railroad Template. The plastic template will ensure precise placement of both track and rotolock latches on both sides of the module. The same template works for all four types of modules and is available in the Lionel onsite store - LionelStore.com. When using the template, the table is assembled first and the template then used to accurately locate the mounting holes for the rotolock components. When placing the rotolock components, the male portion, the larger of the two, is placed on the right side and the female portion on the left side of the module, when facing module with the track side at the front. See the next section and drawing sheets 11 and 12 for additional information on using the template.

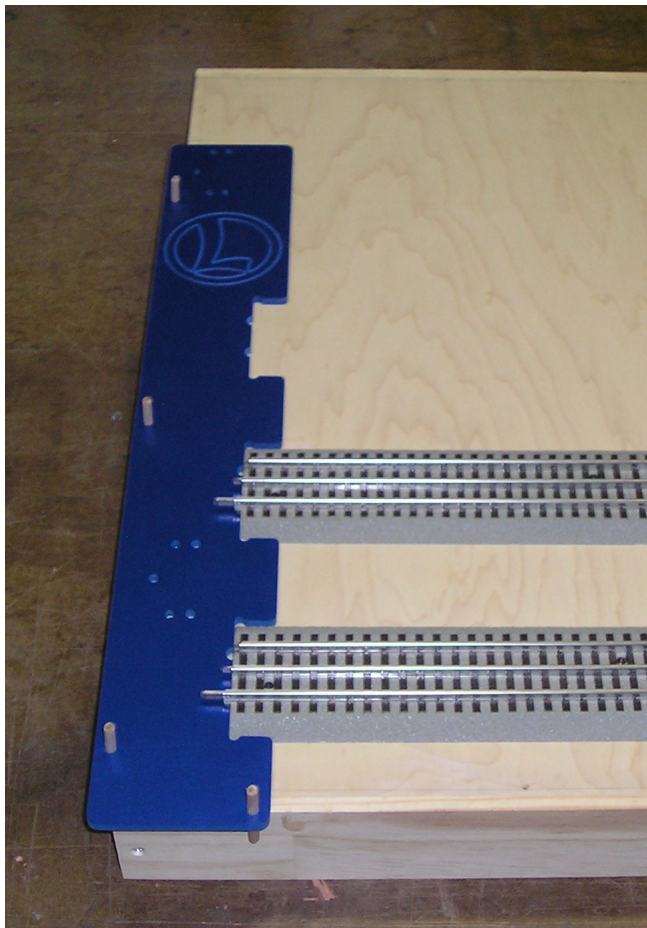

Left side - Lionel "L" face up

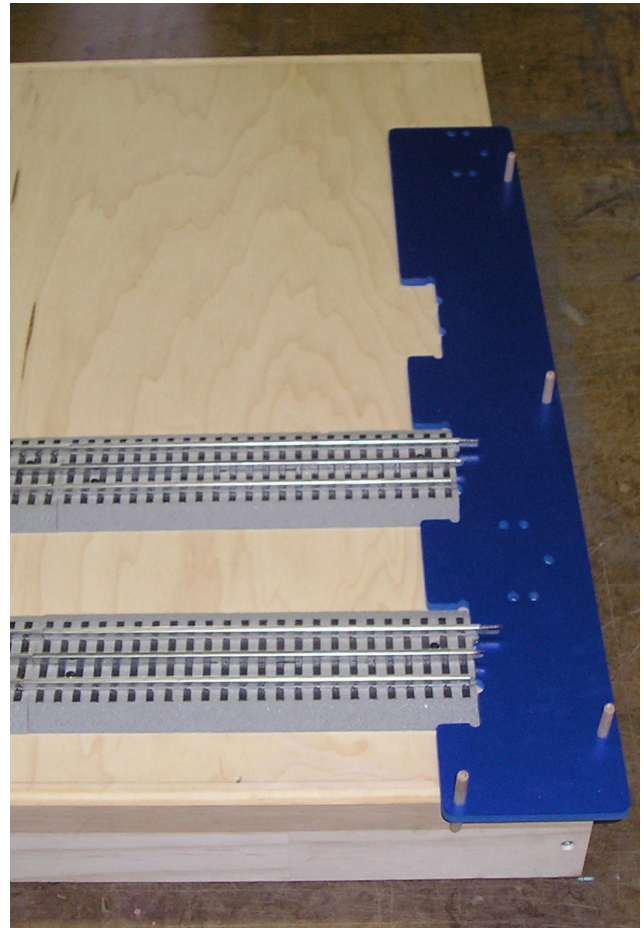

Right side - Lionel "L" face down

Fastrack Modular Railroad Template

The module template provides a way to accurately place the track and the rotolocks on the module to ensure that each module will connect with another. As shipped, the module template must be assembled by inserting the four supplied

wooden dowel pins into the specified holes as shown in drawing sheet 11.

Once the table is built, the module template is placed flat on the table. The portion labeled FRONT in the drawing goes against the long edge of the table nearest the track and the longer portion against the left or right side. For the left side, the template is positioned with the Lionel "L" facing up. Think of the "L" as left. For the right side, the template is turned face down. See drawing sheet 12 for the correct holes to use on each side. The module template can be used with all three types of modules and only one is needed, regardless of how many modules you are building.

Assembling a Reversible Corner

The reversible corner module can be assembled as either an inside or an outside curve. The right and left locations for the wiring harness and the rotolocks will be on opposite sides than stated above if the corner is to be assembled as an inside curve.

FasTrack Requirements

In order to ensure compatibility between modules, there are some strict requirements for the placement of track. Even with these requirements there is the possibility for variety in track layout.

Straight Modules

The straight module allows for the greatest number of options. The minimal requirement would be for two mainlines as shown in drawing sheet 1. Dimensions are given for placement of the two lines. The Lionel FasTrack Module Template will ensure proper placement. The module measures 45 inches in length, but 2 1/2 inches at each end must be allowed for the 5 inch section of FasTrack that will join two modules. This leaves 40 inches which is equal to four 10 inch sections of straight FasTrack. The drawing on sheet 1 shows one 30 inch straight and one 10 inch straight section. This would be the recommended arrangement as it eliminates two track joints on the module.

Each line is spaced 6 inches on center from the next and up to three lines may be used on a straight module. This geometry allows the use of O72 switches to be used between lines if desired. The third line was designed as a siding which can terminate with a bumper or be a passing siding using another straight module and O72 switch to connect again to the second line. [Drawings in the Track Plan section of this manual illustrate plans for adding O72 switches to a straight module.](#)

Corner Modules

The track requirements for the corner modules are more restrictive. The outside line on a corner module is made up of four sections of O84 FasTrack curves. The inner line is made up of two sections of O72 FasTrack curves. This arrangement

was chosen so that even the largest of Lionel's locomotives could be run on either line. Each corner module is 45 degrees, allowing for a variety of configurations. Two are required to make a 90 degree turn.

New Small Radius Corner

In response to many requests, we have designed a new corner module that uses O48 FasTrack curves for the outside line and O36 for the inside line. Only one is required for a 90 degree turn. Plans for this new module are included in the Drawing section of this manual. This new size allows the system to be used in a smaller area and is especially suited for typical home layout applications, or anywhere that space would not permit the larger O84 curves. Please note that in order to allow all Lionel locos to operate, the wider radius modules are preferred for Lionel/LCCA sponsored events.

Module Legs

Legs for the modules are made from 2 x 2 lumber. This type of lumber typically measures 1 1/2 inches square. Each leg is cut at 31 inches tall and a leveler leg installed with the use of a threaded insert. Sources for these are listed at the end of this document. The leveler leg provides an inch of adjustment to the height of the leg. The assembled modules and module kits make use of a steel leg bracket which has been made specifically for these modules. The steel bracket adds support to the module frame and allows each leg to be easily attached and removed. Use of this bracket is not mandatory. The leg can also be attached with a bolt through the outside frame and the leg.

Electrical Connections

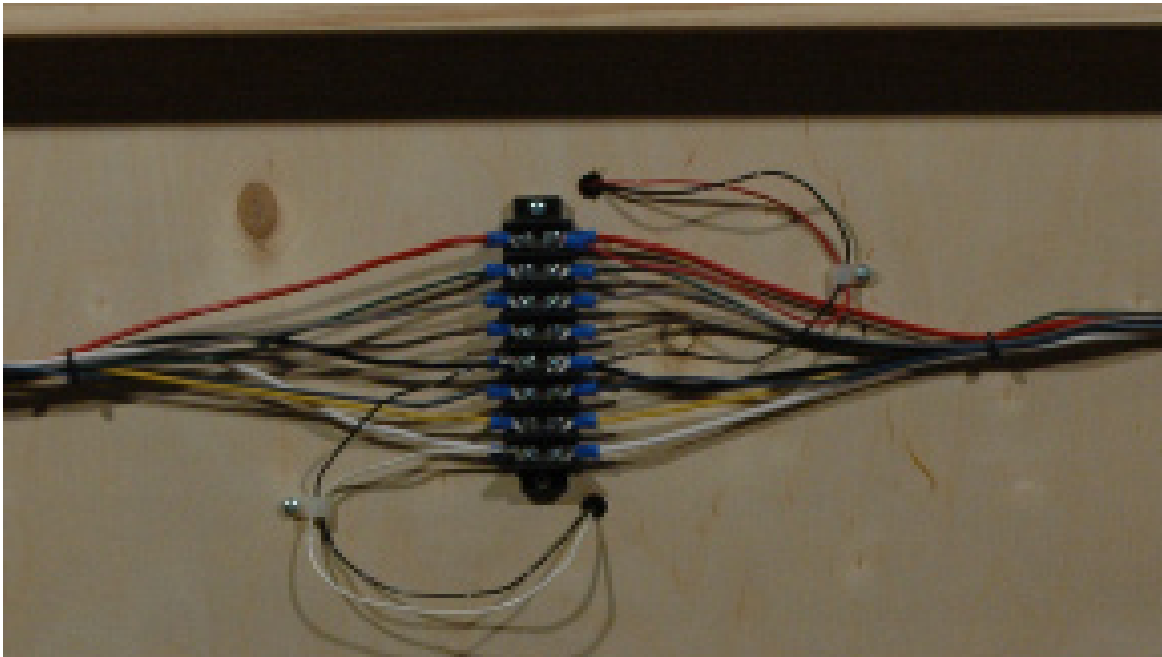

Modules must, of course, also be connected electrically. The electrical connection makes use of a 60 inch 8-wire harness with a male connector at one end and a female connector at the other. This is cut in half, and each of the wire ends connected to one side of an 8-position terminal strip, located on the underside of the module between the two mainlines and in the center left to right. Though not essential, spade terminals were used in the photo below and make a very

Position from front edge of module	Wire Color	Electrical Designation
Top - 1	Red	Outside track (front)
2	Green	Accessory voltage
3	Gray	Earth ground
4	Brown	Accessory voltage
5	Black	Common for all
6	Blue	Accessory voltage
7	Yellow	Optional third track
8	White	Second inside track

clean connection. They can be sourced from most hardware stores. As with the rotolocks, the harness is positioned so that when the module is in its upright position, the male end is at the right side. Connections from the track to the terminal strip can be made using the wire supplied with the 6-12016 FasTrack Terminal Section or the 6-12053 Lionel accessory power wire.

The photo on page 9 shows a view of the underside of a wired straight module. Each of the wires on the harness is a different color and the following table indicates the correct order of wires as the harness is viewed from the underside as in the photo. Notice also the holes drilled into the top, under the two track lines for wires which then connect from the track to the terminal strip. It is best to drill these holes from the top once you know exactly where the track connections are to be made.

Power Connections and Legacy Command Control

Once a layout of modules has been assembled, power must be supplied to the tracks. Transformer power is connected to one of the the 8-position terminal strips. A corner modules is probably the most convenient. On the initial layout built by TW Trainworx, a separate table measuring 30 inches wide by 24 inches deep, was constructed for the transformers. This table was 24 inches tall and was located on the inside of one of the narrow reversible corner modules. When planning on creating a control station, this footprint is suggested. This table size worked well and fit nicely into the table plan.

Mike Reagan, Lionel’s director of Customer Service will be supplementing this manual with a video providing additional information regarding power distribution and implementation of Lionel’s Legacy Command Control. Mike’s video will be

added to the many already posted at www.Lionel.com and YouTube. A corner module is probably the most convenient, but any module can be used. Depending on the size of the assembled layout, more than one transformer may be necessary - one for each track line for example. Separate transformers may also be used to power the accessory line. The module system has been designed with Lionel's Legacy Command Control system in mind. The 180 watt PowerHouse can be used for one of the lines designated as a Legacy line or one for each of the lines if the assembled layout is designated as Legacy only.

Electrical Tests

Once a module is completed, we strongly recommend that it be tested with a continuity tester or a simple ohm meter. One bad track joint, or one wire incorrectly connected would result in failure when connected with other modules. A demonstration of each of the following tests can be viewed on the video. We recommend the following tests:

- On the wiring harness, touch one meter lead to each pin on the male side while the other meter lead touches the corresponding socket hole on the female side, i.e. red to red, white to white etc. Test each color individually to be sure you have continuity from one end of the harness to the other. For example the pin connected to the red wire should show continuity with only the socket of the same color on the opposite end of the harness. Each pin should only have continuity with its matching color.
- On top of the module, check that each rail has continuity from from one end of the module to the other by placing a lead at each end of the same rail - you should have continuity.
- Next test continuity from each of the center rails to each of the 8 pins on the male end of the harness. You should show continuity on only one pin and that pin color should match the above table, i.e. outside track center rail shows continuity only with red wire. All other pins must show no continuity.
- Finally test each of the outside rails with one meter lead connected to the black wire. With the other lead touch each of the rails, one at a time. There should be continuity with all outside rails, but not with any of the center rails.

Sources

8 Wire Harness - 60 inches long
Del City Part #74825 - delcity.com

8 position terminal strip
Del City - Part #70018

Leveler Mount
McMaster Carr - Part #23015T82 - mcmaster.com

Threaded insert
McMaster Carr - Part #90267A697

Rotolock
Mutual Hardware - Part #H2001 - mutualhardware.com

In Conclusion

A video demonstrating the construction and electrical testing of a module from the kit can be viewed at www.Lionel.com. Watch also for Mike Reagan's video on Power Distribution and Legacy Command Control.

Members will be kept up to date with frequent updates to this site. Also planned are some illustrations of several different layout designs using the modules. Our hope is that you'll find this new way to become involved in the hobby exciting. Watch for special Lionel and LCCA events where module owners can assemble their units into a large layout. All modules to be used in a sponsored run are to be certified compatible with the published standards. There will be a compatibility test requirement before a module is placed in service.

Our hope is that you become involved with the Lionel FasTrack Modular Railroad and find great enjoyment putting together a large layout and running your trains at a Lionel or LCCA event.

Credits

These specifications and the design of the Lionel FasTrack Modular Railroad are the result of a joint effort between Lionel L.L.C. (www.Lionel.com) and the Lionel Collectors Club of America (www.Lionelcollectors.org). A special thanks goes to all of the committee members for their work in completing this task. I would also like to thank Lionel President Jerry Calabrese, LCCA President, Dennis DeVito and the LCCA Board of Directors for approving this project.

Final design details and drawings were by TW TrainWorx.
Template design and additional drawings by Wellington Enterprises

Respectfully submitted,
Bill Schmeelk - Committee Chairman

Committee Members

Ed Boyle (LCCA)
Roger Farkash (LCCA)
Joe Fea (Lionel L.L.C.)
Larry Franzen (LCCA)
Mike Reagan (Lionel L.L.C.)
Gary Richman (Lionel L.L.C.)



Lionel

FastTrack

Modular Railroad

Drawing Package

Ver 2.0

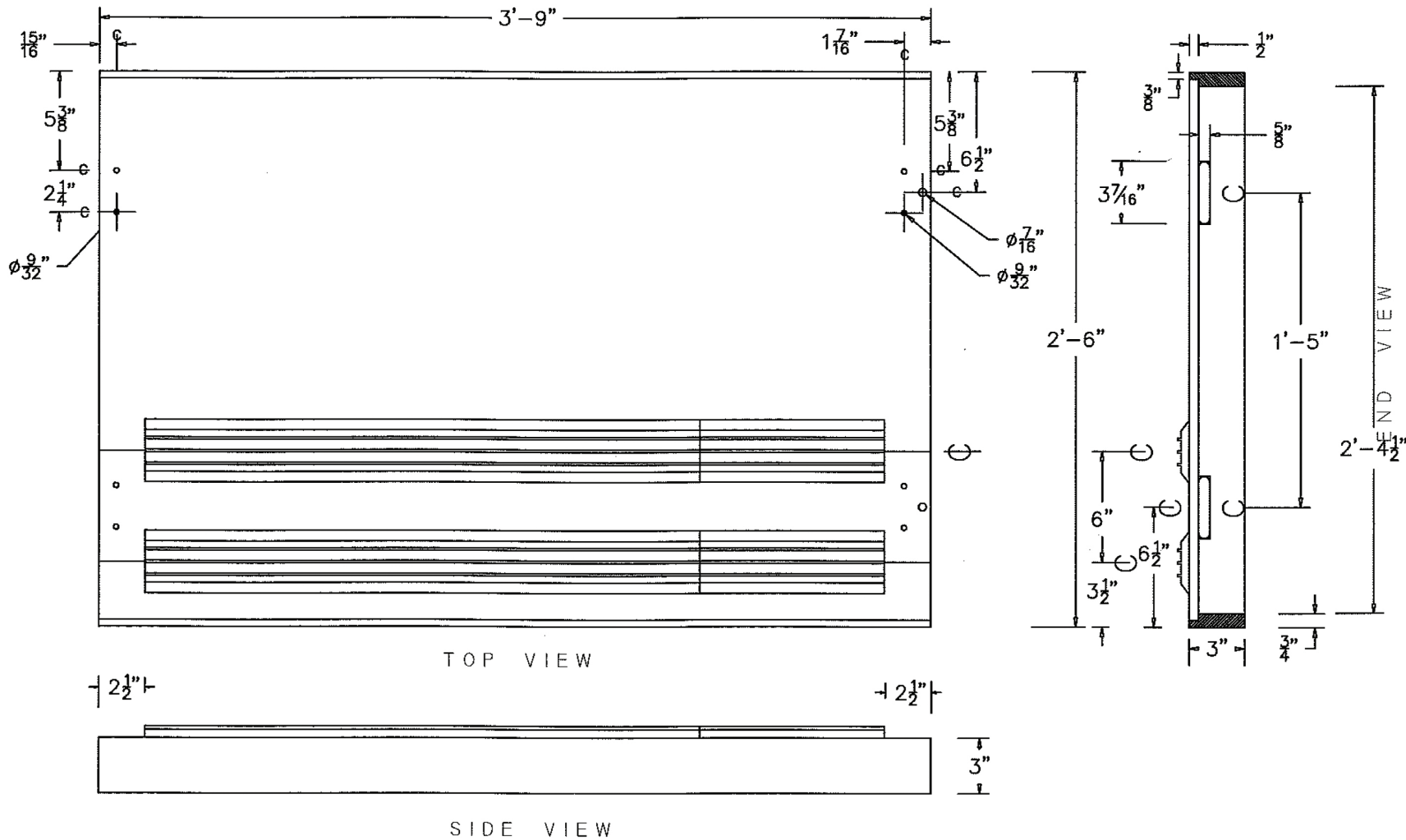

SCALE : 1-1/2" = 1'-0"

Straight Module Dimensions



Lionel FaTrack Modular Railroad

Sheet 1

Rev 2.0 12/12/12

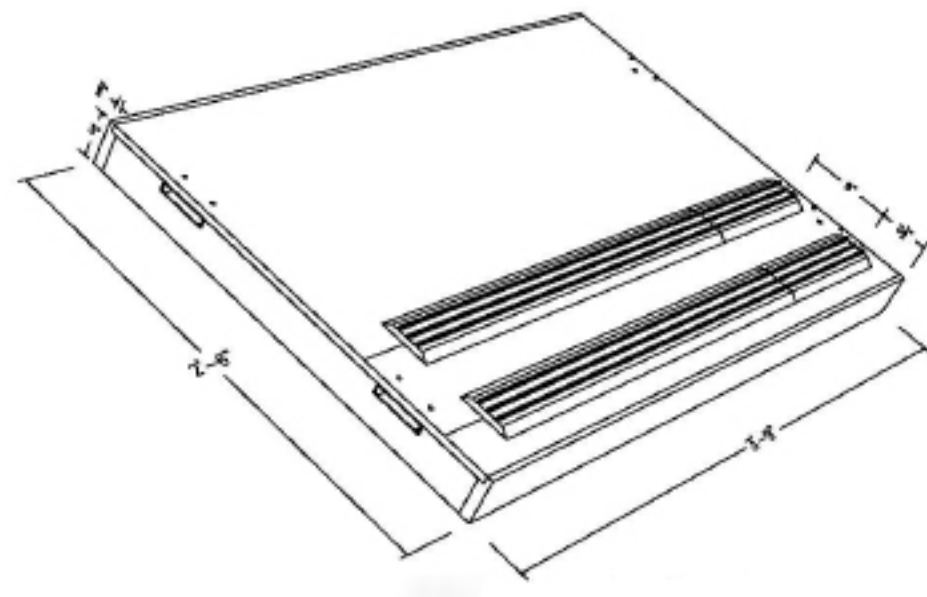
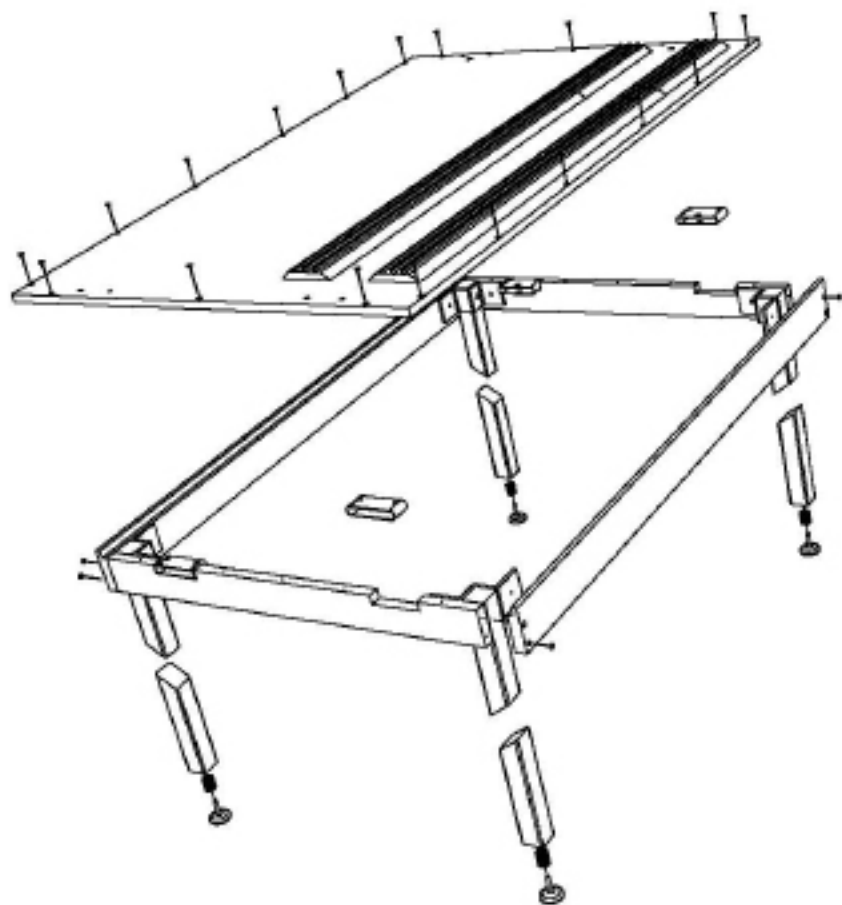

Straight Module Assembly



Lionel FaTrack Modular Railroad

Sheet 2

Rev 1.0 8/25/12

NOTES:

1. Miter angle on each of the three pieces along the outside edge is 11 1/2 degrees.
2. Miter angle on each of the two inside pieces is 22 1/2 degrees.

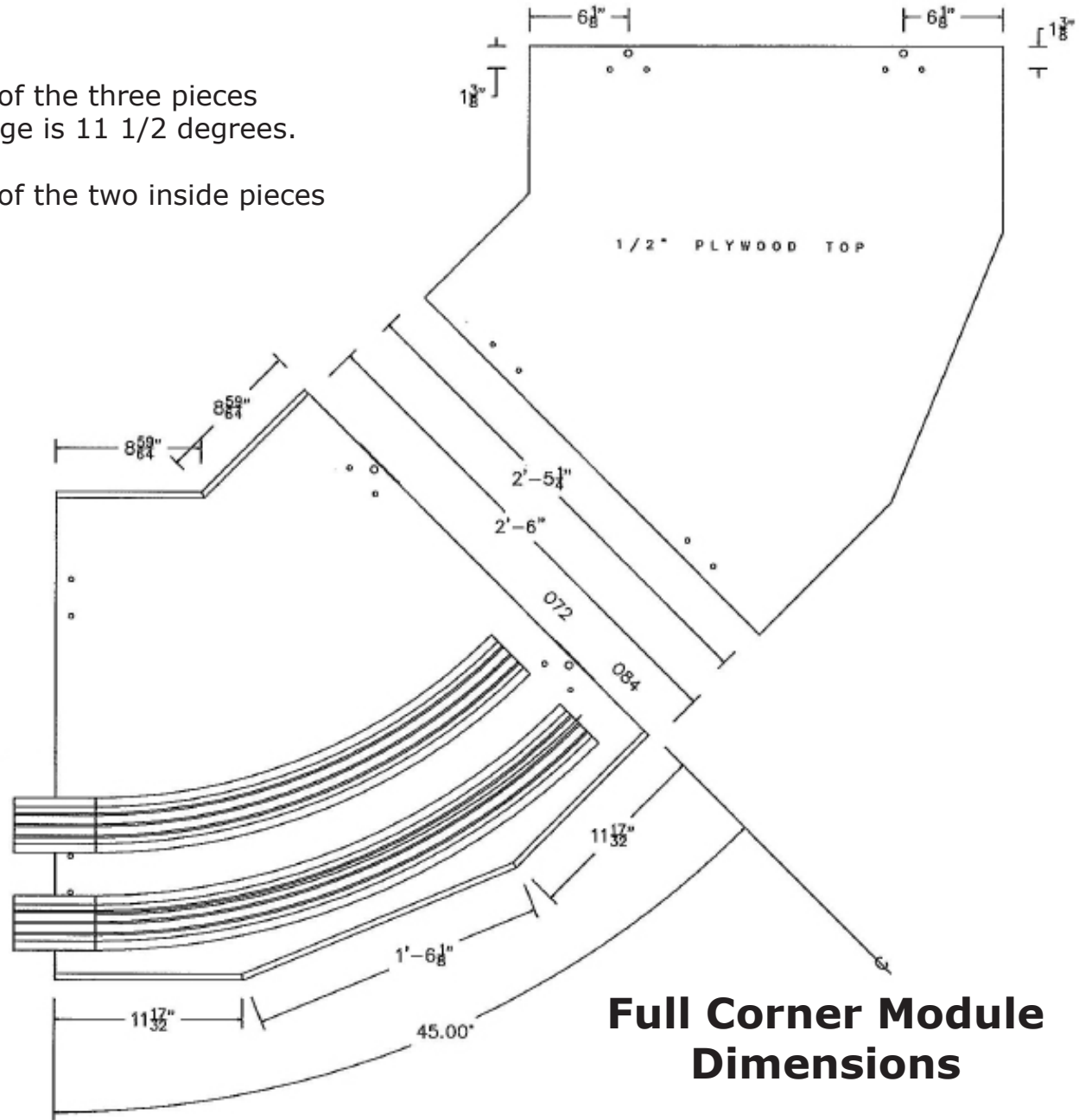

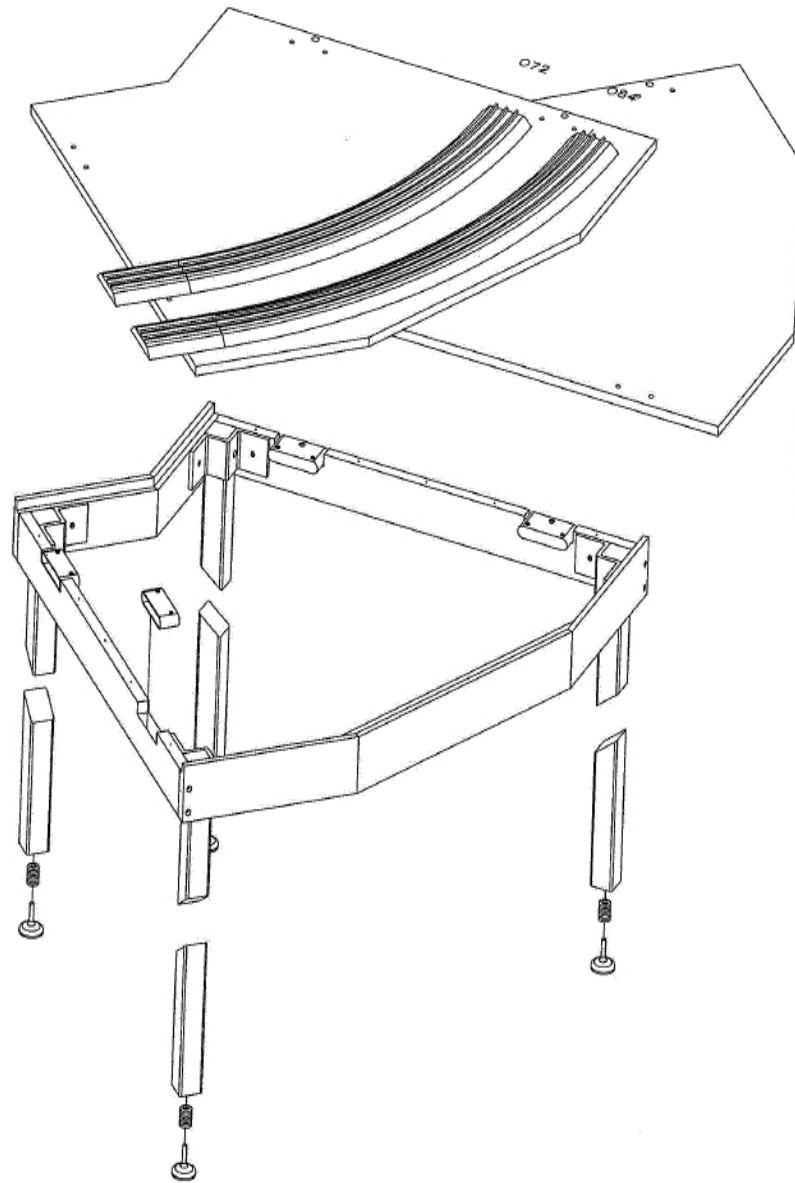

REPEAT ADJACENT
45 DEGREE CURVE UNIT
TO COMPLETE
90 DEGREE CORNER

Full Corner Module Assembly



Lionel FaTrack Modular Railroad

Sheet 4

Rev 1.0 8/25/12

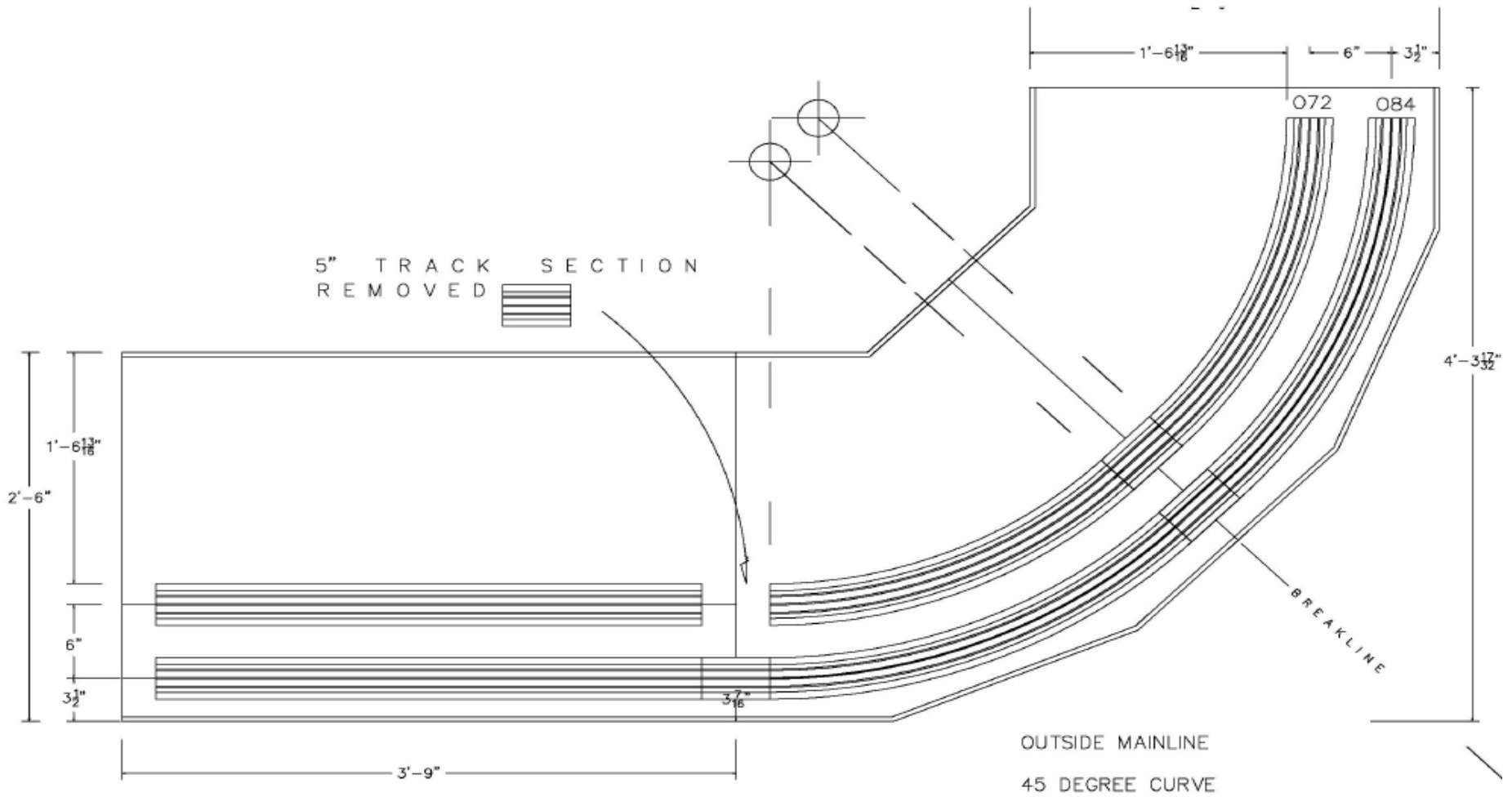

Assembled Modules with Track



Lionel FaTrack Modular Railroad

Sheet 5

Rev 1.0 8/25/12

NOTES:

1. Miter angle on each of the three pieces along the outside edge is 11 1/2 degrees.
2. Miter angle on each of the three inside pieces is 11 1/2 degrees.

Reversible Corner Modules Dimensions

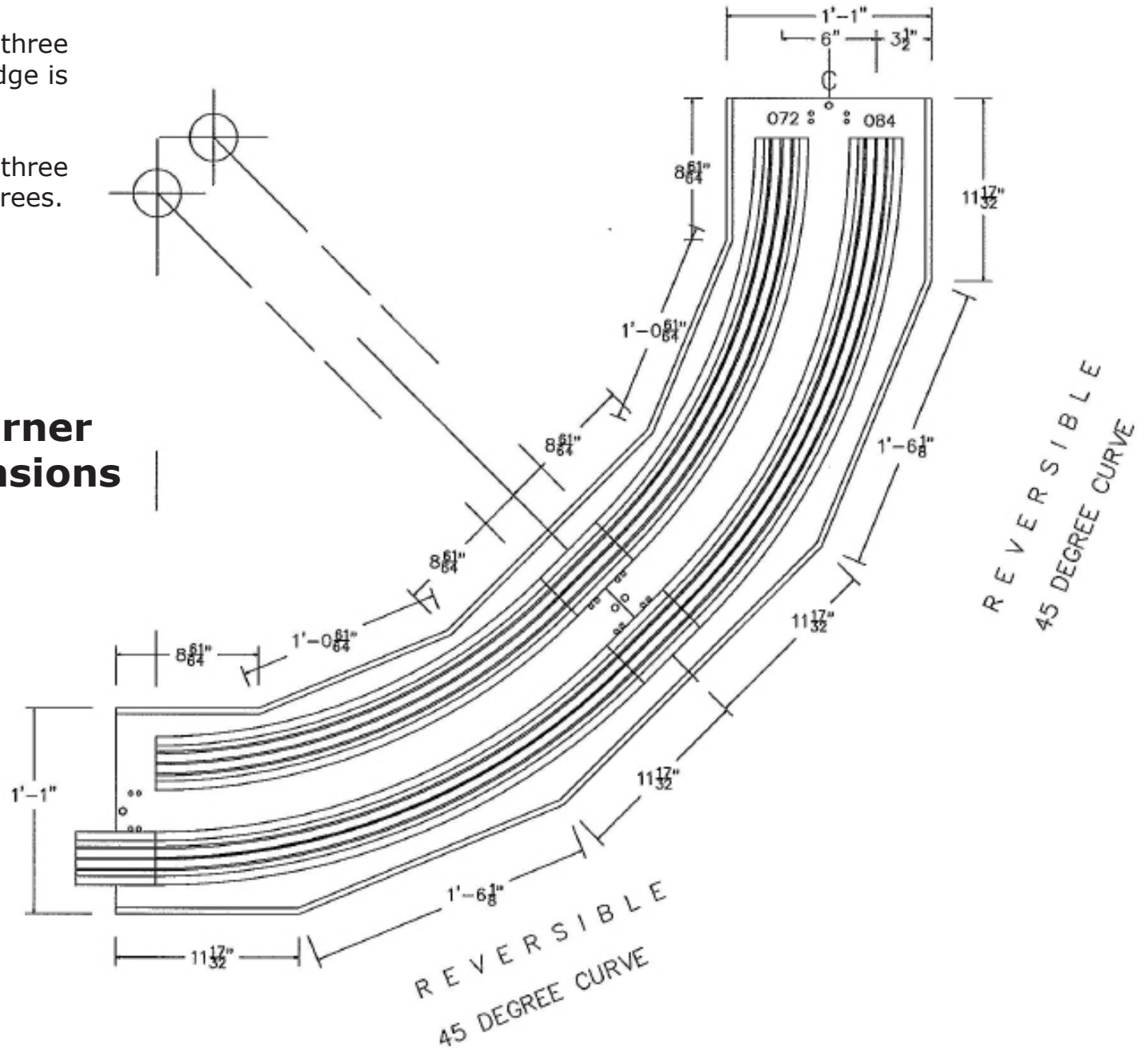

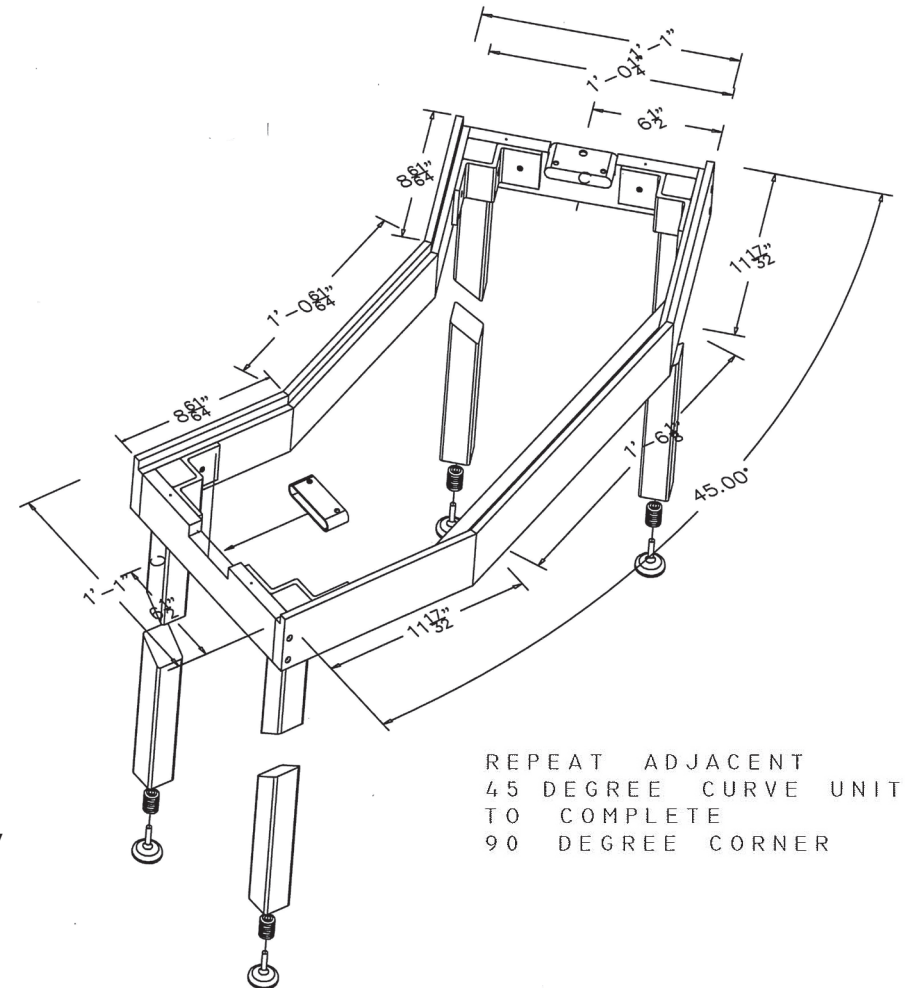
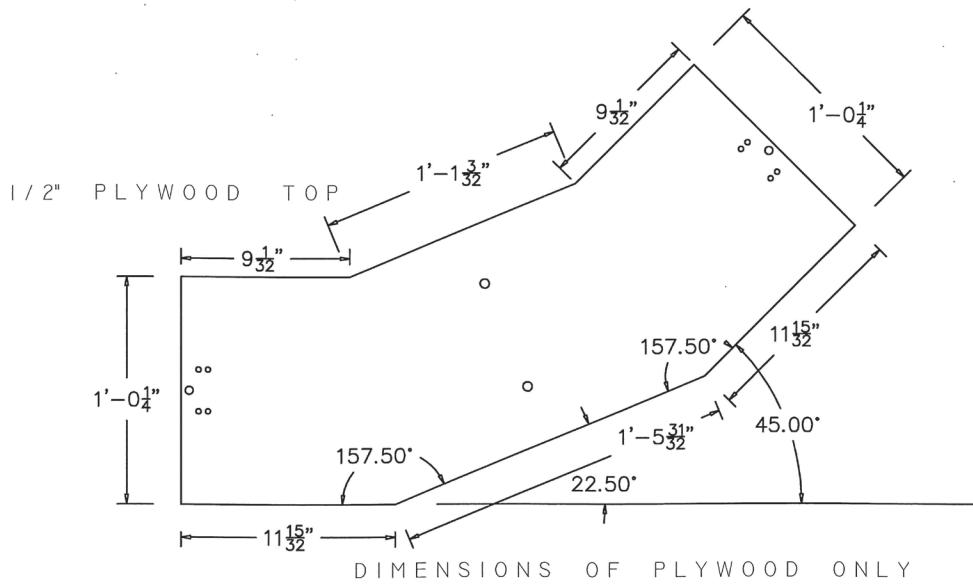

REPEAT ADJACENT
45 DEGREE CURVE UNIT
TO COMPLETE
90 DEGREE CORNER

Reversible Corner Module Assembly



Lionel FaTrack Modular Railroad

Sheet 7

Rev 1.0 8/25/12

NOTES:

1. Height of bracket is 2 inches and is formed from 1/4 inch thick steel.
2. Height of wooden 2 x 2 leg is 31 inches.
3. Actual dimension of leg commonly sold as a 2 x 2 is 1 1/2 x 1 1/2 inches
4. Bottom of leg is drilled with 11/32 inch drill, 1 inch deep to accept 1/4-20 threaded insert and adjustable leveler.

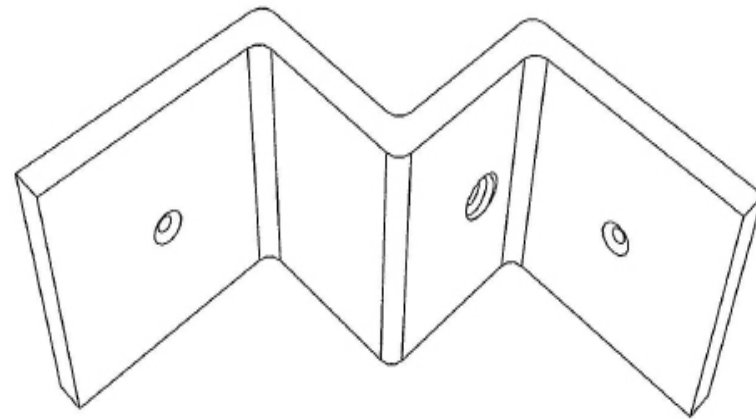

Steel Leg Bracket

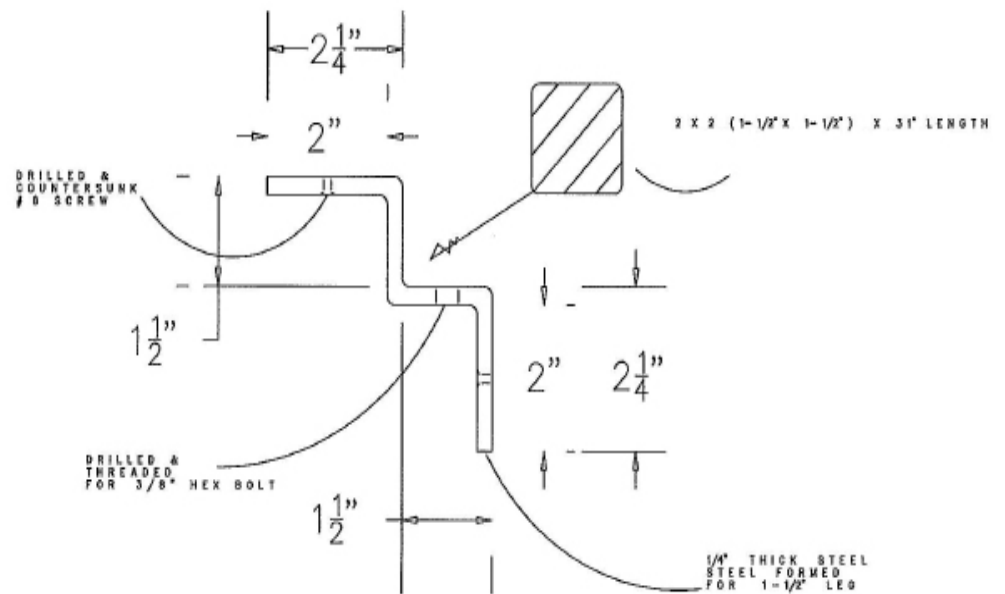

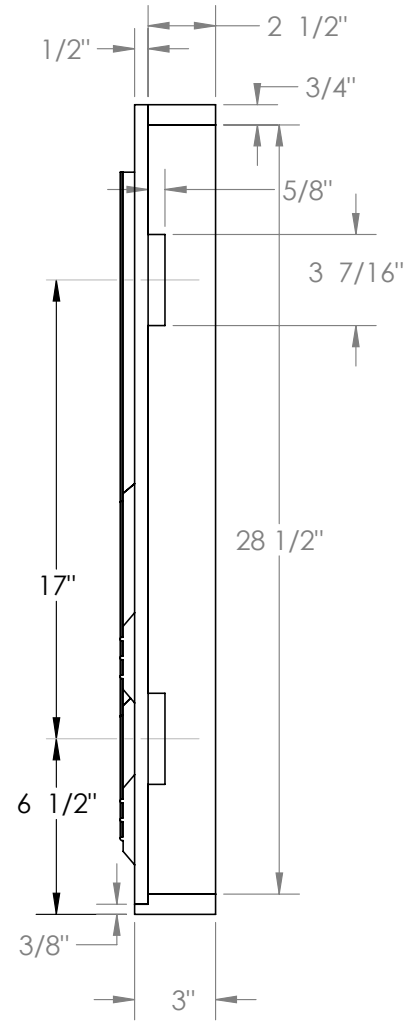
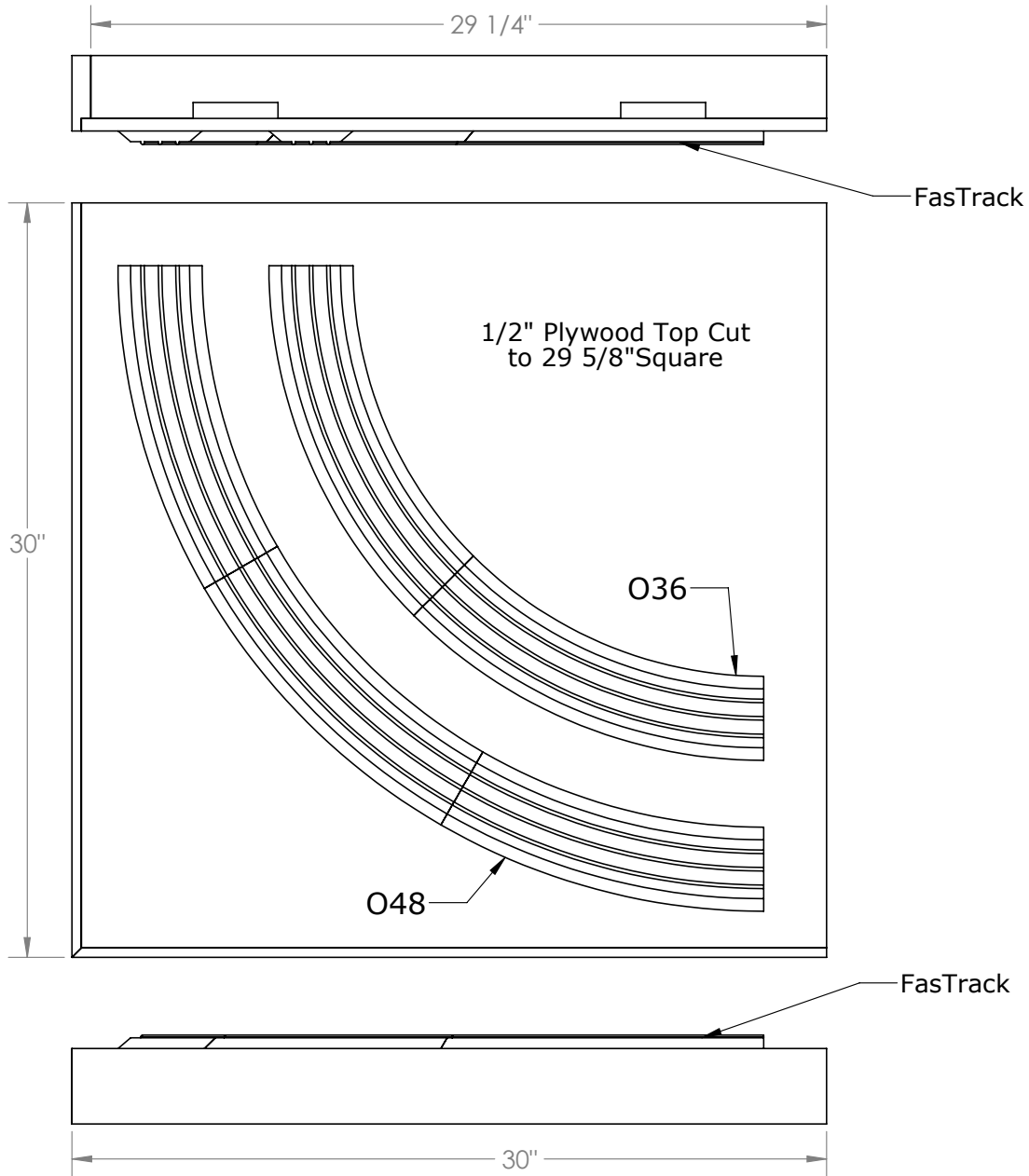

Small Radius Module



Lionel FaTrack Modular Railroad

Sheet 9

Rev 1.0 12/12/12

The two outside rails are rabbeted for the 1/2" top and are mitered at this corner. Both are 30" long

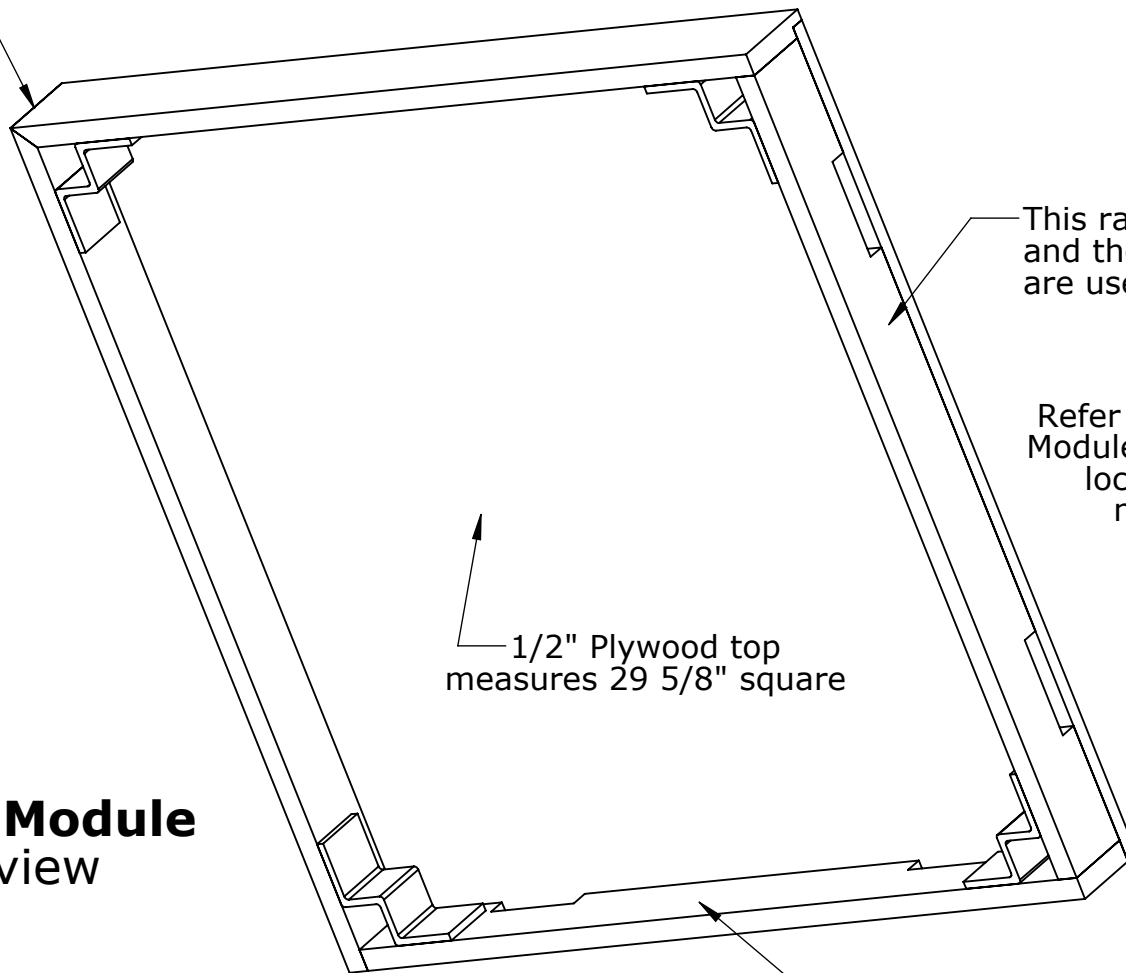

This rail is 28 1/2" long and the male rotolocks are used here.

Refer to Sheet 1 Straight Module drawing for typical location of rotolock mounting holes

1/2" Plywood top measures 29 5/8" square

This rail is 29 1/4" long and the female rotolocks are used here.

Small Radius Module Underside view



Left Side of Module

For drilling holes on the left side of the module as you face the front, use the template with the Lionel "L" side facing up.

To assemble the template, place one of the 2 inch dowels into each of the four holes along the edge of the front and left side. Hammer the dowel in place so that it extends above the template on each side about 7/8 inch.

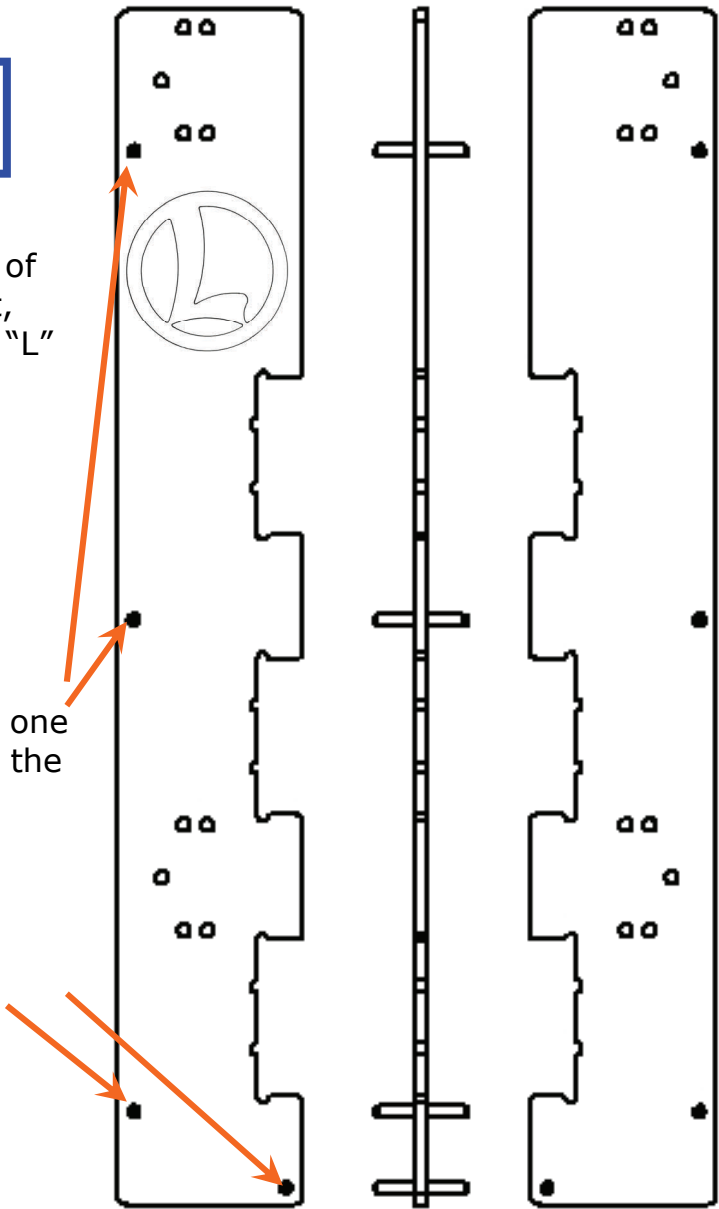

Right Side of Module

For drilling holes on the right side of the module as you face the front, use the template with the Lionel "L" side facing down against the table.

Module Template

Front of Module
(long side nearest the track)



Left Side of Module

Use only these two holes at top and bottom of template to drill for female (smaller) portion of rotolock.

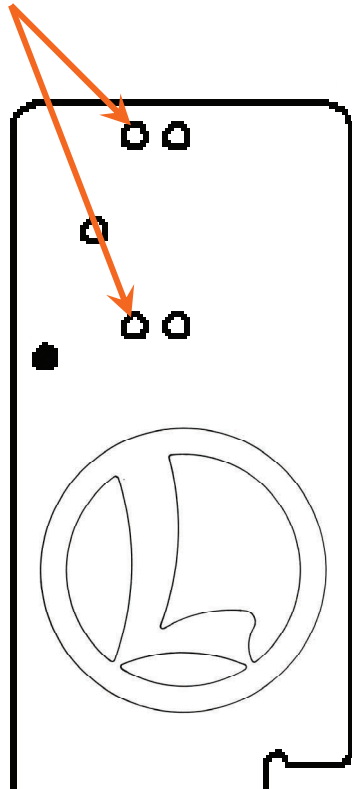

Module Template

Use only a 1/4 inch drill for all drilling through the template

Use this hole at top and bottom of template to drill for rotolock wrench. After drilling with template, enlarge the hole on the module to 7/16 inch. Once the rotolock is mounted to table, this hole is used with the rotolock wrench to operate the rotolock.

Right Side of Module

Use these two holes at top and bottom of template to drill for male (larger) portion of rotolock.

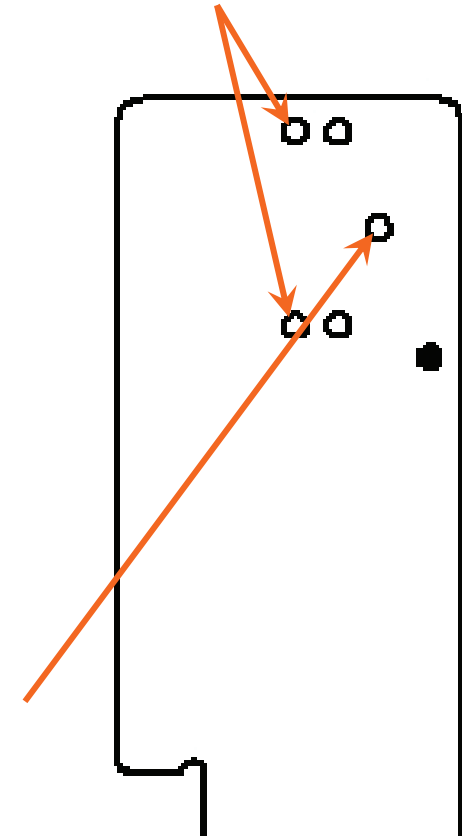

Front of Module



Lionel FasTrack Modular Railroad

Sheet 12

Rev 10 8/25/12



Lionel

FastTrack

Modular Railroad

Track and Module Layout Plans

Planning Your Layout

The following pages illustrate several examples of how modules might be combined to make a layout. Depending on the available space, each of them can be modified with the addition or removal of straight modules.

The 45 degree and reversible corners allow the modules components to be arranged in many creative configurations. Just a few ideas follow to stimulate your thinking.

The basic guidelines of configuration are:

1. Maintain the 45 degree corner modules in pairs so that each corner is 90 degrees or 180 degrees.
2. Any number of straights can be added between 90 degree corners - BUT **GENERALLY** NOT BETWEEN INDIVIDUAL 45 degree modules. So, for examples, an **L** and a **U** are illustrated in sheets 16 and 17. The straight runs can be extended to any length and can be asymmetrical - for example, one arm of the U could be much longer than the other. Using the alphabet as the base template it would be easy to create layouts that are variations on **E, F, H, T**, even **V** and **W** with 90 degree angles.
3. The exception to guideline #2: Two 45 degree modules of a 90 degree corner can be separated by straight sections if symmetry is maintained. The **Dog Bone** and **Modified Oval** plans, seen in Sheets 18 and 19, are examples. These two plans are similar and use the same end configurations.
4. A linked pair of one inside and one outside curve can be matched to a second pair to keep the geometry in balance. The **Off Center Dog Bone** on Sheet 20 illustrates this configuration principle.

We will be anxious to see your layout ideas and refine these layout guidelines.

Adding Switches

Sheets 13, 14 and 15 illustrate how O72 switches can be incorporated into track plans for straight modules. The O72 switches can be combined between two track lines and maintain the 6 inch centers established for the FasTrack Modular Railroad. Some of these track combinations require a number of smaller sections. The more track sections within a module, the more chance there is for a loss of power between track joints. For this reason, it is recommended that additional drops from the the track to the power connections under the module be made. This will ensure that power is not lost.

Another alternative is to replace several of the small sections of FasTrack with a custom cut length of FasTrack. The additional work to custom cut a track section

will eliminate the number of joints and reduce the number of track sections needed. For example, the track plan shown on sheet 14 incorporating two switches, requires 12 sections of FasTrack. If three custom cut sections are used, the total number of sections needed is reduced to six. The appendix includes detailed instructions on how to go about making custom FasTrack sections.

For Lionel/LCCA events it is preferred that no switches be used in the outer loop of track.

Also included in the Appendix is a handy reference chart showing how sections of FasTrack can be combined to achieve specific lengths.

Track Plan for a Siding to a Third Line

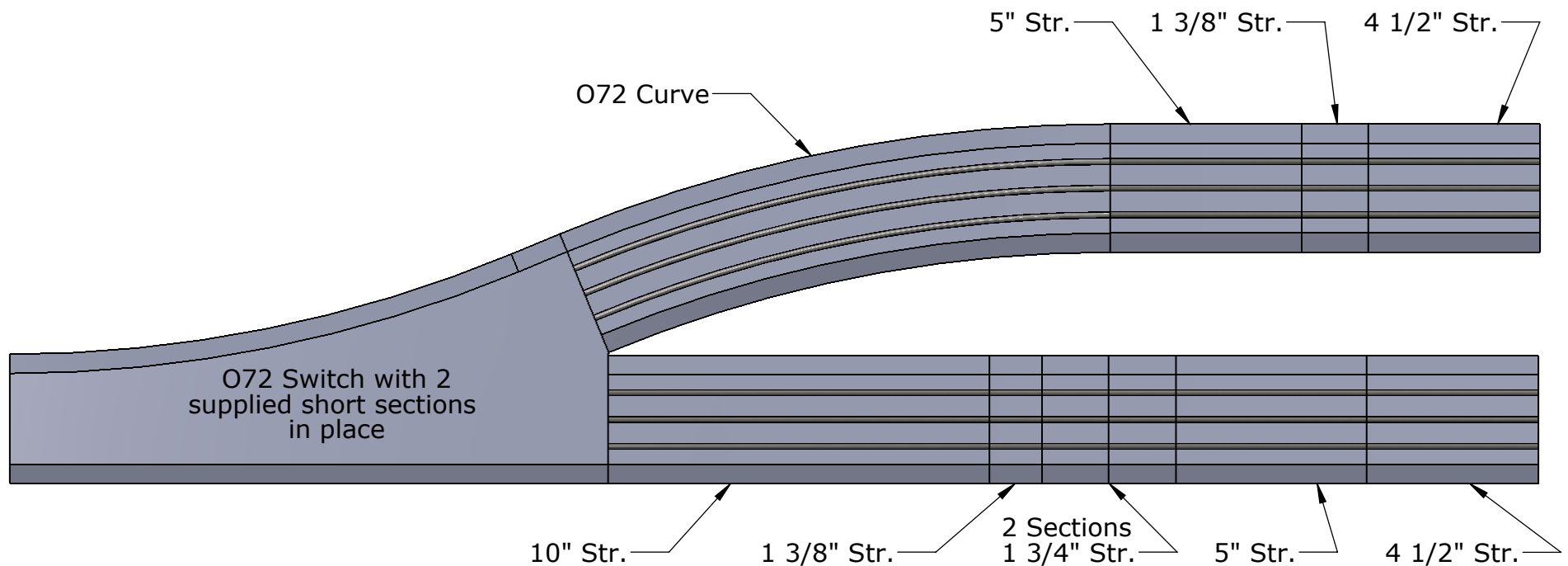

NOTES:

1. This arrangement is designed to be used between the second (inner) line and a third line.
2. A mirror image of this arrangement using Right hand switches can be used to complete a passing siding on another module.
3. This arrangement requires 9 sections of straight track. Due to the increased number of track joints, it is recommended that additional drops from the track to power bemade.
4. The number of straight sections can be reduced to 5 if 2 of them are custom cut as follows:
 The curved portion would require a custom cut straight $6 \frac{3}{16}$ " long.
 The straight portion would require a custom cut straight $9 \frac{11}{32}$ " long.
 See Appendix for instructions on cutting custom lengths of FasTrack.



Adding O72 Switches to Lines 1 and 2

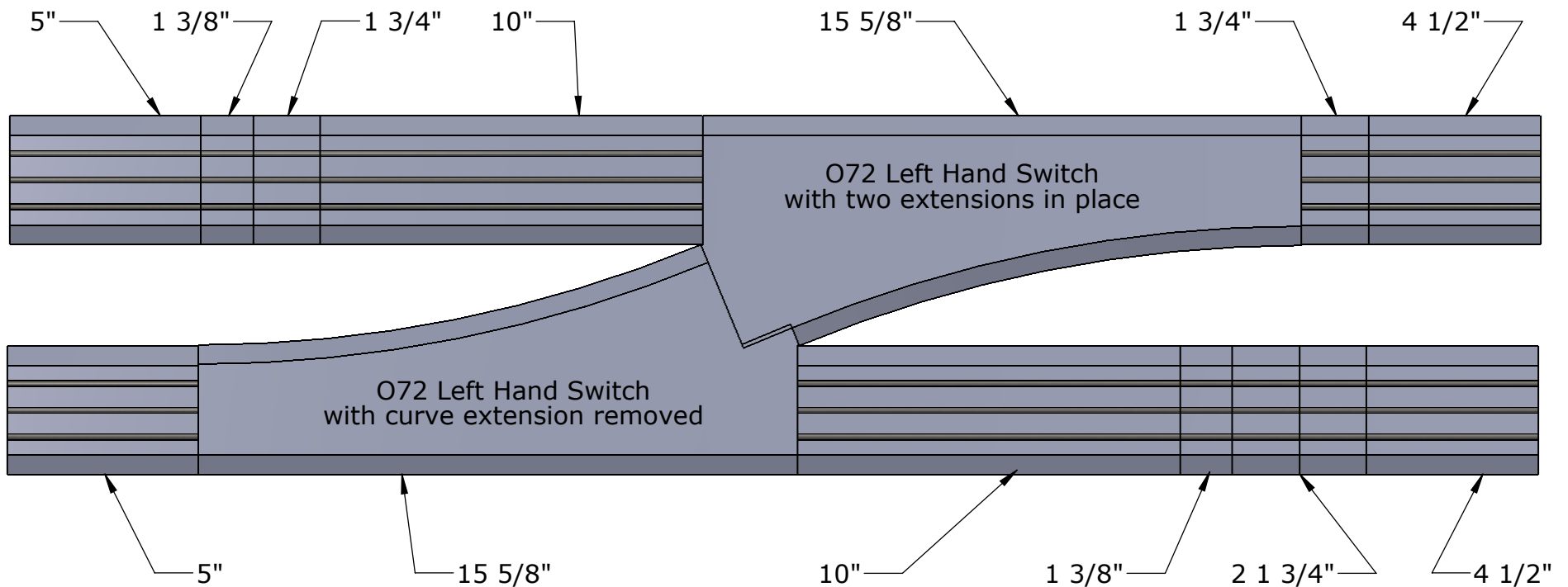

Notes:

1. This arrangement is designed primarily to connect the two outside lines, lines 1 and 2.
2. Note that the 1 3/8" extension to the curve on one of the switches has been removed to maintain the 6 inch spacing between the two lines. All other extension pieces, one on each straight and one on a curve, remain in place.
3. Ideally, this same arrangement would be duplicated on another module using right hand switches. This would allow trains to change from one line to the other and back again. With only one such module, a train would have to reverse to return to its original line.
4. Due to the number of track joints in this arrangement, it is recommended that additional drops from the track to power be made.
5. By cutting custom track sections the total number of sections can be reduced - See Appendix for instructions on how to do this.



Module Plan with Switches

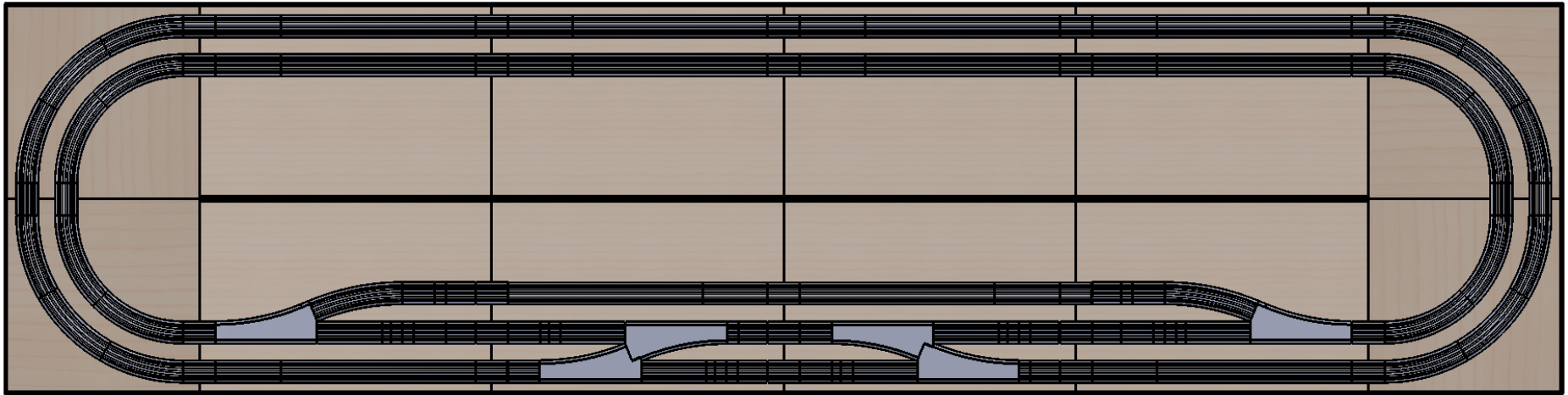

Notes:

Although the above plan illustrates the use of the Small Radius Module, the straight module plans shown could also be used with the larger radius corners. See Sheets 13 and 14 for exact track plans for each of the straight modules.

The two modules that each contain two switches between the outer two lines can also be separated. For example one might be on the opposite side of the layout. Having both of them allows a train on either line and operating in either direction to travel from one line to the other and back again.

If desired, straight modules can be added between the corner modules to increase the width of the layout. A straight module between two Small Radius Modules measures 105 inches. Substituting the larger radius corners would result in a layout width of just over 103 inches.



"L" Shape Module Plan

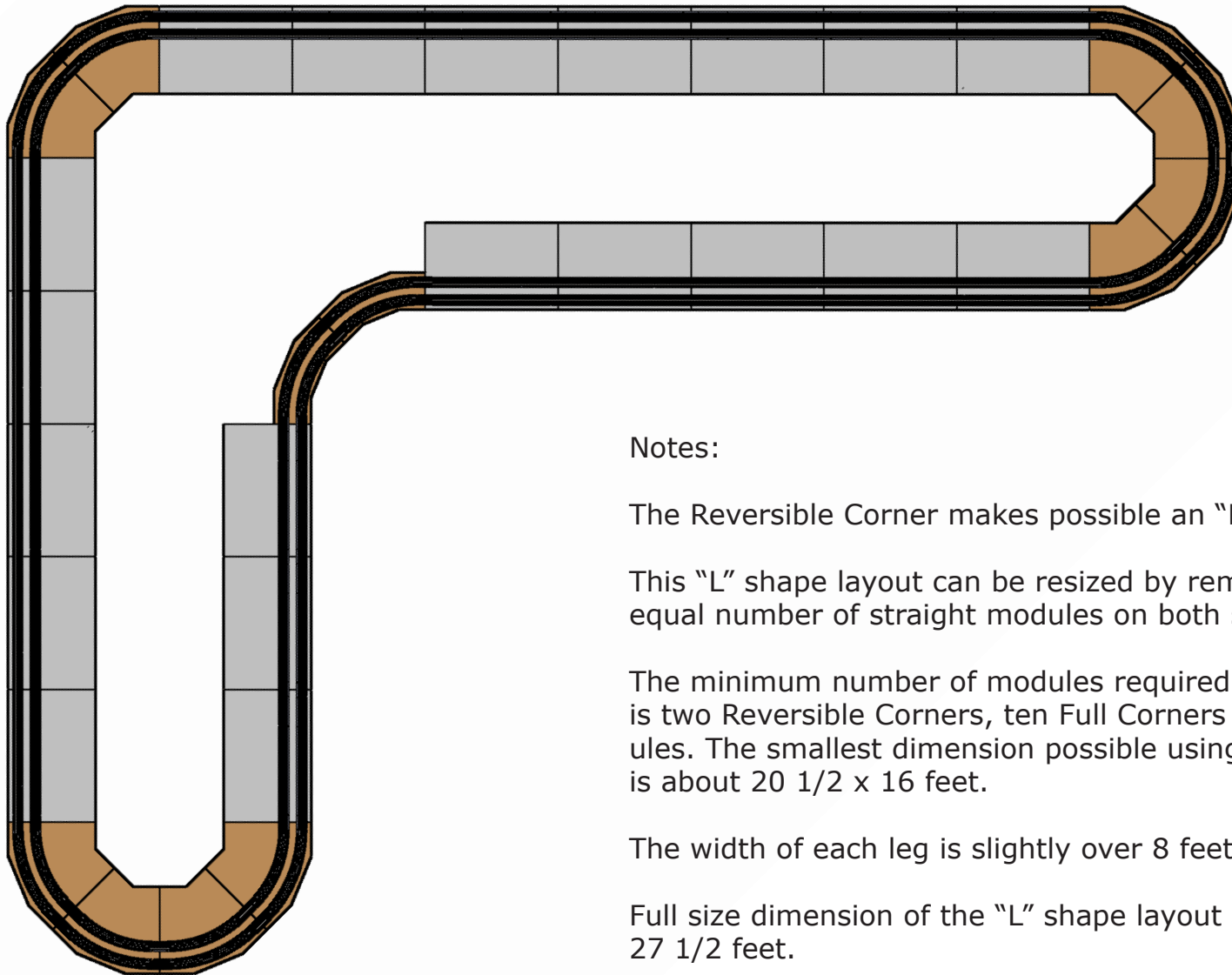

Notes:

The Reversible Corner makes possible an "L" shape layout.

This "L" shape layout can be resized by removing or adding an equal number of straight modules on both sides of either leg.

The minimum number of modules required for an "L" shape layout is two Reversible Corners, ten Full Corners and four Straight Modules. The smallest dimension possible using this minimum number is about 20 1/2 x 16 feet.

The width of each leg is slightly over 8 feet 7 inches.

Full size dimension of the "L" shape layout as shown is about 35 x 27 1/2 feet.



"U" Shape Module Plan

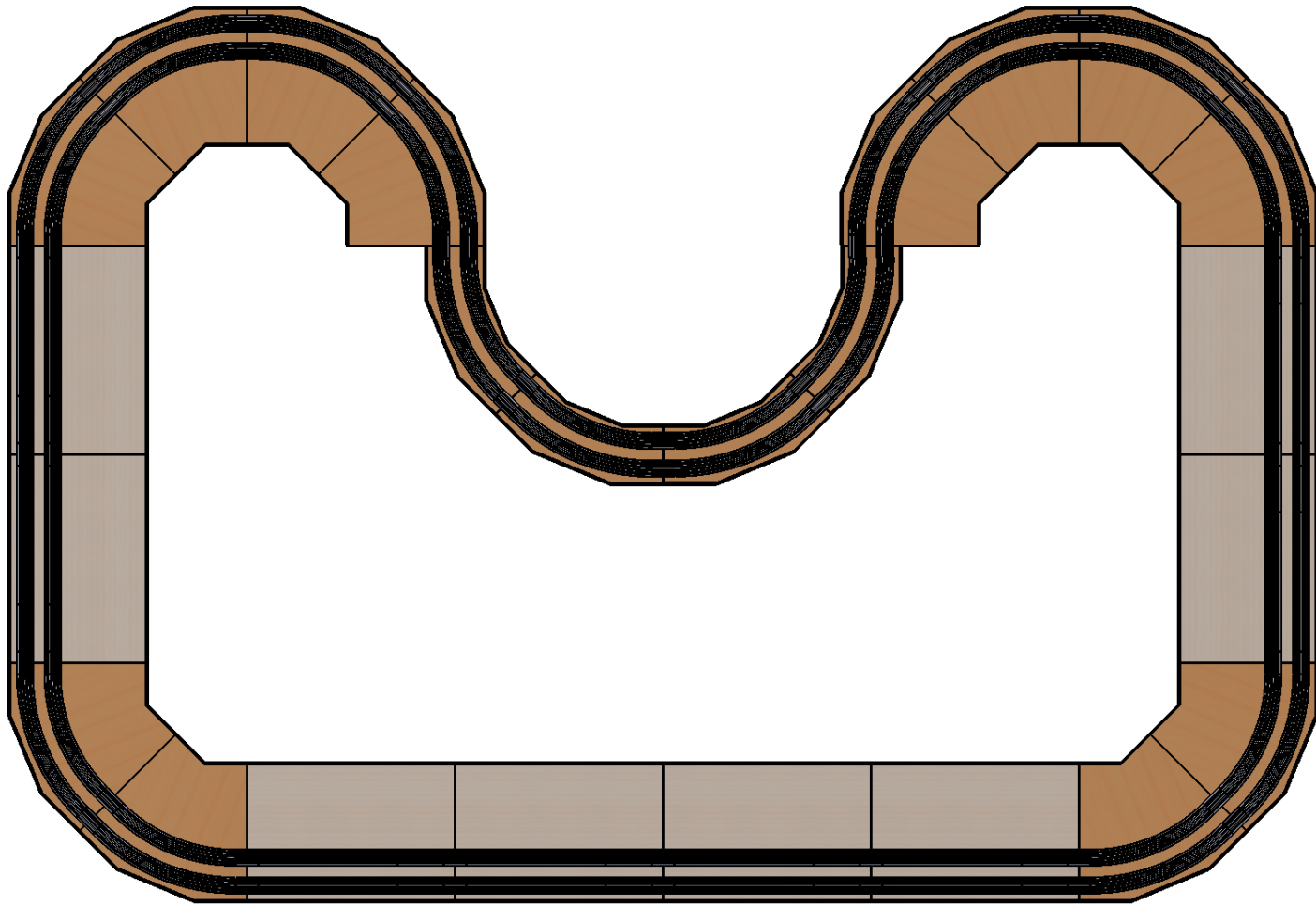

Lionel FaTrack Modular Railroad

Sheet 17

Rev 1.0 12/12/12

Modified Oval Layout

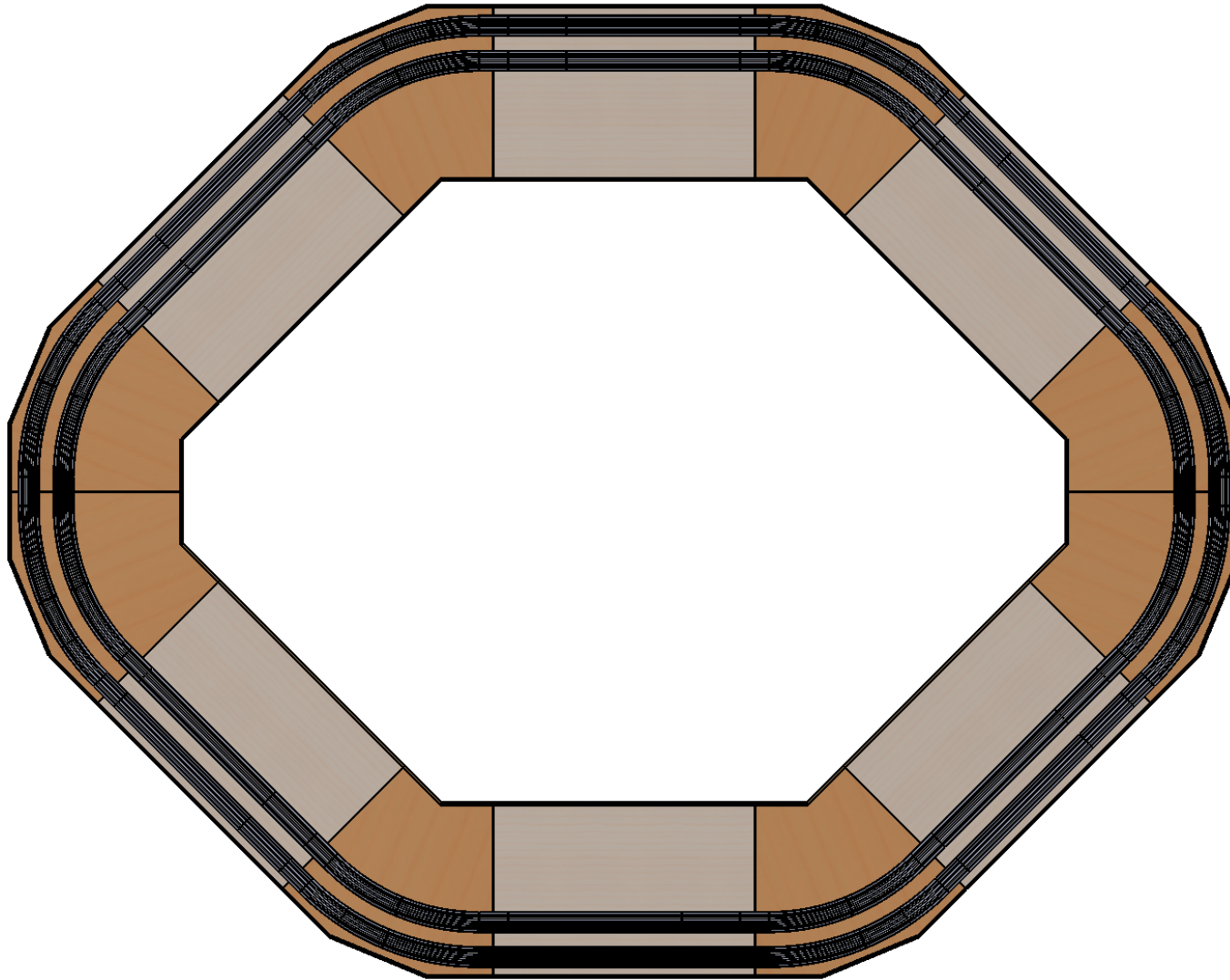

Lionel Fastrack Modular Railroad

Sheet 18

Rev 1.0 12/12/12

Dog Bone Layout

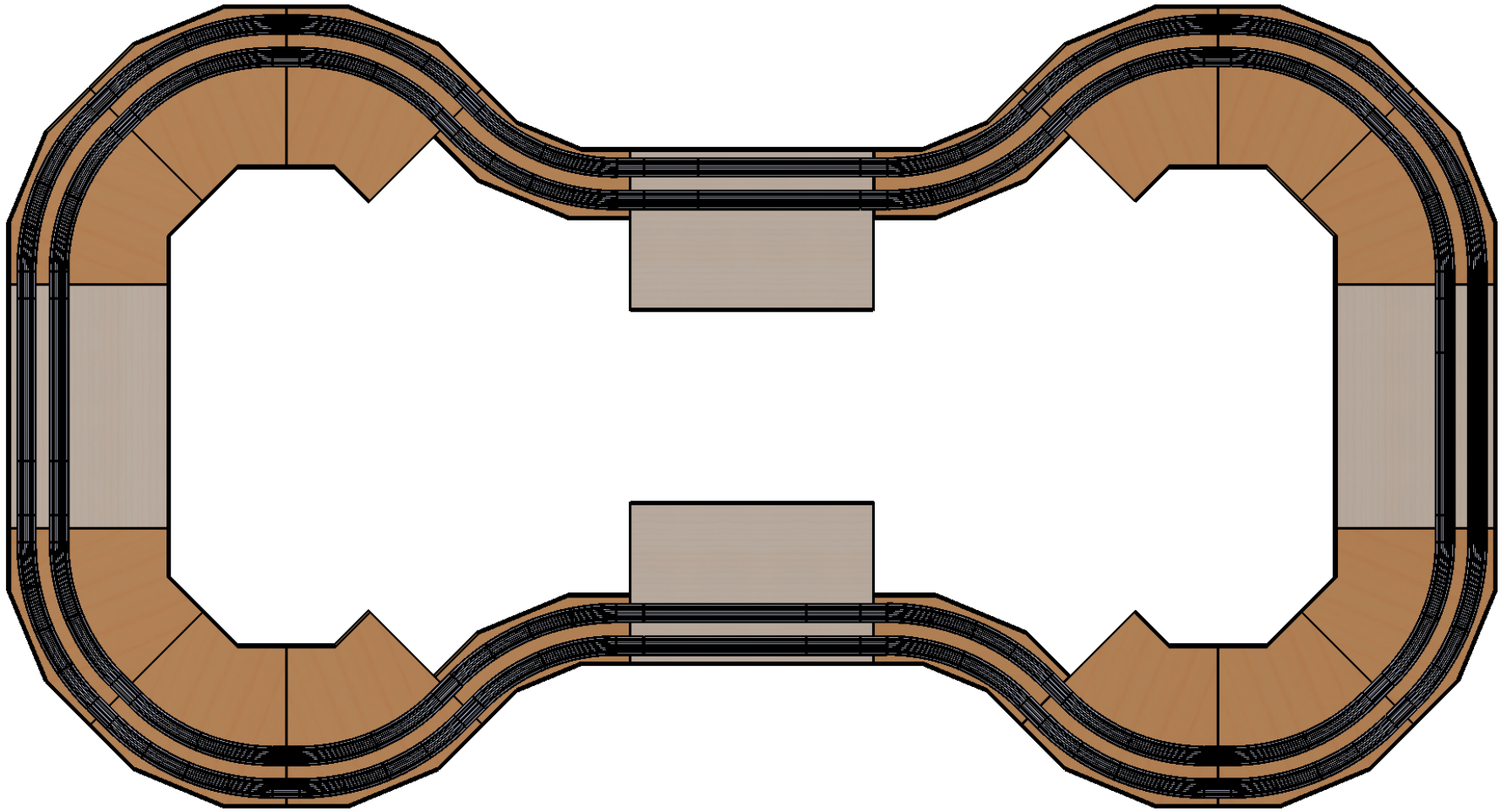

Off Center Dog Bone Module Plan

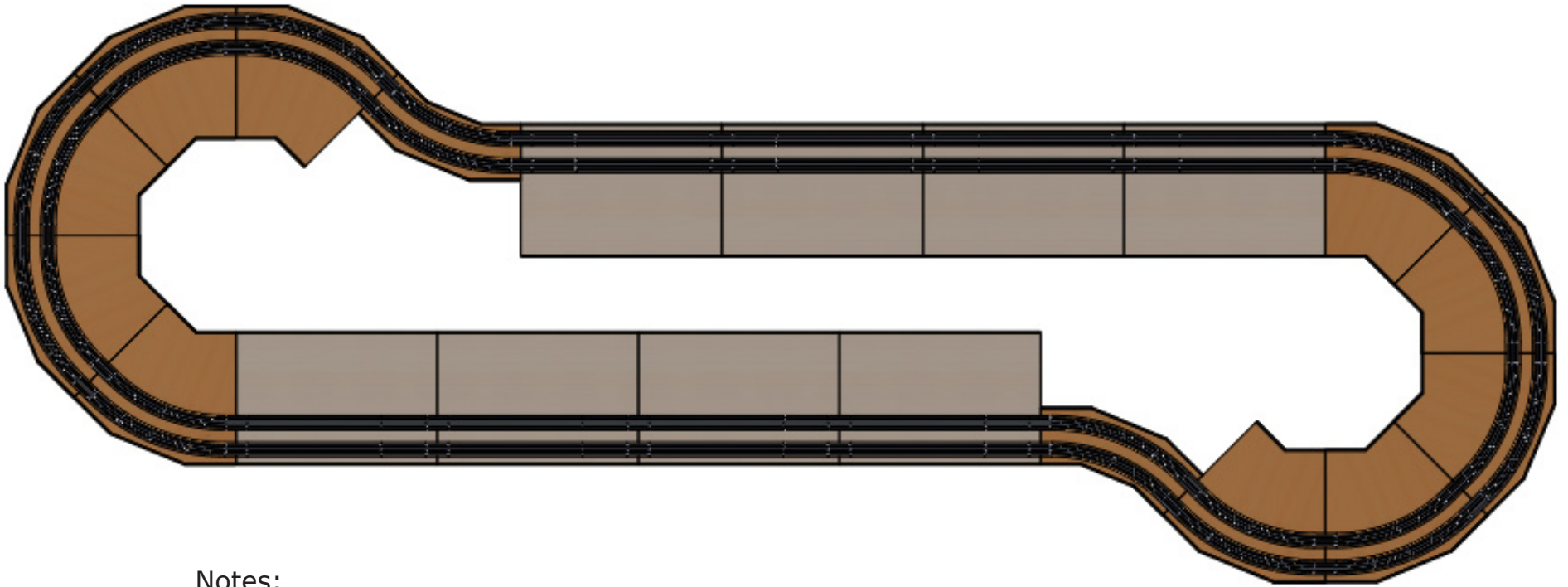

Notes:

Minimum requirements for smallest size would be 2 Reversible Corners, and 10 Full Corners. In the above illustration four Straight Modules were added to each side.

In its minimum configuration (no Straight Modules) this layout would require about 14 x 11 feet.

As illustrated above, this layout would require about 29 x 11 feet.



Lionel FaTrack Modular Railroad

Sheet 20

Rev 1.0 12/12/12



Lionel

FastTrack

Modular Railroad

Appendix

by Bill Schmeelk
HM 6643

New FasTrack Section – To Cut or Not To Cut

In the previous issue of *TLR*, we published a chart of track lengths that could be assembled using different combinations of FasTrack™ lengths. Although the addition of the 1-3/8-inch track section more than doubled the possible lengths that can be assembled, there are times when there might be a better answer. For instance, let's say you just finished assembling your layout and to complete it, you find that you need an 8-1/4-inch section. Great – refer to the chart for 8-1/4, and you'll find that such a section can be made by connecting six 1-3/8-inch sections. While making a section of that length is possible, an 8-1/4-inch section with six joints is not the most efficient method, nor is it economical.

In this case, the best answer is to custom cut a special section. As we discussed last issue, cutting FasTrack is a bit more complicated than cutting tubular track. You can't simply cut a piece off the end. If you did that, the section would not mate with any other FasTrack section, with the possible exception of the O-gauge transition piece. There is a better way; simply cut a section out of the middle of a track section. Before attempting to explain the procedure, I tried it myself and what follows is a complete description with photos on what I feel is the best method to make custom lengths of FasTrack.

Let the Cutting Begin

For our example, let's assume I need a section that is 8-1/4 inches long. If the section you want is less than 10 inches, it will only require one standard section of FasTrack. We want to remove a section from the middle and reassemble the track. That leaves us with a section that retains the two original ends and can easily be connected to other sections of FasTrack. The first decision is exactly where the first cut will be made. If you look at the underside of a section of FasTrack, you'll notice the bent metal tabs which secure the rails to the plastic roadbed. When the track is cut, you want to leave as many of these remaining in place as possible. You also want to avoid cutting the track over the metal plate which connects the two outer rails. If need be, this plate can be removed before cutting. Subtracting the length we want (8-1/4 inches) from the full length of 10 inches, we get a length of 1-3/4 inches to be cut away from the middle of the track in order to preserve the two ends of the track.

Cutting the track square is very important. For that reason, a miter box is a very efficient method. I purchased an inexpensive plastic one at a home improvement store. One feature that I liked was that its front side had a lip which overhangs the table and holds the miter box in position as you cut on the forward stroke of the saw. Typically, a back saw is used with a miter box. This is not acceptable for

cutting metal, and I substituted a hacksaw with a 32-teeth-per-inch blade.



Photo 1 shows the setup as the sawing proceeds. You must hold the track firmly while sawing. Once you get through the metal rails, the cutting will go quickly. After the first cut was made, I positioned the two pieces as shown in

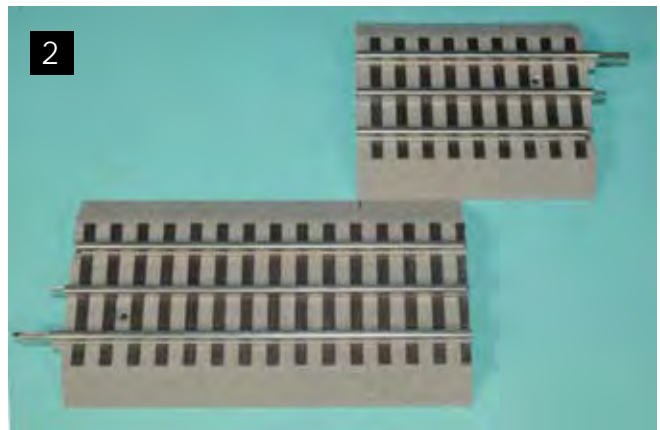
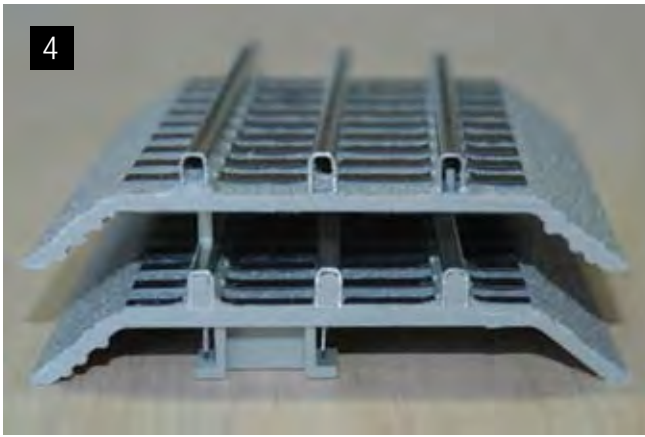

photo 2 and set them so that the measurement from the end of the cut piece to the end of the remaining piece was my desired track length – in this case, 8-1/4 inches. I then marked the larger section at the point where the smaller section ended. This is where the second cut must be made on the larger piece. This is cut in the same manner as before, using the miter box.



Photo 3 shows the result. The very short middle piece can be discarded. Next I used a sanding block with 120 grit sandpaper and carefully smoothed the cut edges. Be careful not to sand it too much; all you want to do is remove the saw marks and leave a smooth, square edge for gluing. It takes very little sanding to achieve this. If you sand too much, you may lose the squareness of each piece and they will not mate perfectly. **Photo 4** shows the two cut edges after sanding.



The next step is to drill into each of the rails at the cut end of each piece. This is done with a 7/64 inch drill as shown in **photo 5**. The drilling is necessary because there are plastic supports spaced at about 1/4-inch intervals under each



rail. These can be seen if you look at the small section to the left of the track being drilled in **photo 5**. Drill to a depth of at least one half the length of an O-gauge track pin. Be sure to keep the drill against the inside top of the rail and support the rail from above with your finger.

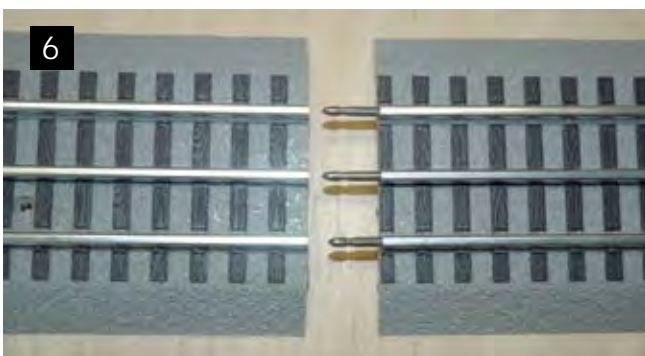

Now place a standard O-gauge track pin into each rail of one of the sections as seen in **photo 6**. You can now press the two sections together for a test fit. If you've been careful, the rail tops and the roadbed will line up properly. For the glue to hold properly, the joint of the two sections of roadbed should touch without any gaps. Next, separate the two sections and place the pins in one section. Sparingly apply Superglue™ (cyanoacrylate) to the edge of the roadbed

on the section without the pins. Place both sections on a flat surface and push them together and hold them tightly for about 10 seconds. Although many of these glues are called instant, their full strength is not developed for up to 24 hours. We're almost finished, but there is one more important step.

One Last Step

To assure the best conductivity, the rails of each section of the new piece should be soldered together. I usually prefer stranded wire, but in this case, the joint will not be moving and solid wire is quite suitable. I used 18-gauge copper wire. **Photo 7** shows the completed soldering. In this particular case, I soldered to the connecting plate. Depending on the

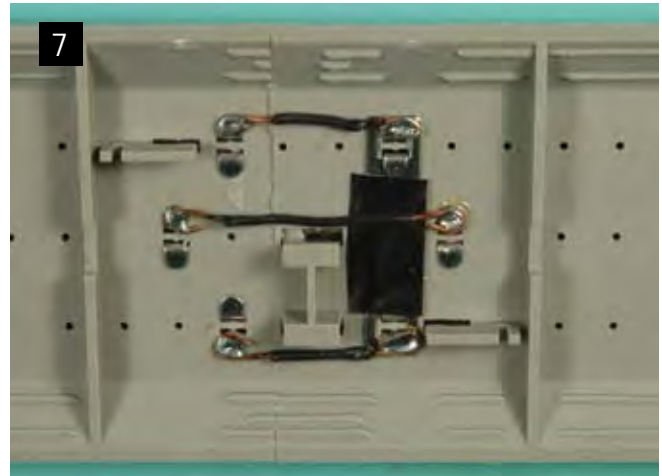

length you are making, this plate may not be there. Simply solder from the metal tabs of one rail to the tabs of the same rail on the other section. Do this with all three rails. Notice that in my example, I had to bring the center rail wire across the plate which connects the two outer rails. It is very important that this center rail wire does not make contact with this plate as that would result in a short circuit. I assumed that I would have no problem as the wire insulation would keep any contact from occurring. I discovered however, when I soldered the wire, that the insulation shrunk and bare wire came very close – too close – to the plate. I then removed the center wire and placed a piece of electricians tape over the plate. If I had it to do over again, I might simply remove the plate or at least loop the center

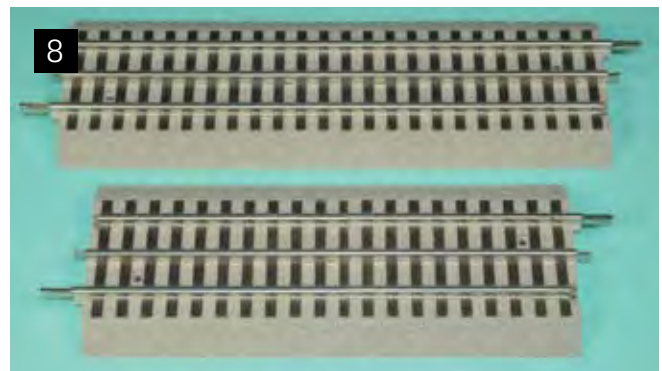

wire so that it approaches the connection from the opposite side. **Photo 8** shows the completed section along with a standard 10-inch piece for comparison.

Lionel Fastrack Size Table

Length	1 3/8	1 3/4	4 1/2	5	10	Pieces
1 3/8	1					1
1 3/4		1				1
2 3/4	2					2
3 1/8	1	1				2
3 1/2		2				2
4 1/8	3					3
4 1/2			1			1
4 7/8	1	2				3
5				1		1
5 1/4		3				3
5 1/2	4					4
5 7/8	1		1			2
6 1/4		1	1			2
6 3/8	1			1		2
6 5/8	1	3				4
6 3/4		1		1		2
6 7/8	5					5
7		4				4
7 1/4	2		1			3
7 5/8	1	1	1			3
7 3/4	2			1		3
8		2	1			3
8 1/8	1	1		1		3
8 1/4	6					6
8 3/8	1	4				5
8 1/2		2		1		3
8 5/8	3		1			4
8 3/4		5				5
9			2			2
9 1/8	3			1		4
9 3/8	1	2	1			4
9 1/2			1	1		2
9 5/8	7					7
9 3/4		3	1			4
9 7/8	1	2		1		4
10					1	1
10 1/8	1	5				6
10 1/4		3		1		4
10 3/8	1		2			3
10 1/2	4			1		5
10 3/4		1	2			3
10 7/8	1		1	1		3

11	8					8
11 1/8	1	3	1			5
11 1/4		1	1	1		3
11 3/8	1				1	2
11 1/2		4	1			5
11 5/8	1	3		1		5
11 3/4		1			1	2
11 7/8	5			1		6
12		4		1		5
12 1/8	1	1	2			4
12 1/4	2		1	1		4
12 3/8	9					9
12 1/2		2	2			4
12 5/8	1	1	1	1		4
12 3/4	2				1	3
12 7/8	1	4	1			6
13		2	1	1		4
13 1/8	1	1			1	3
13 1/4		5	1			6
13 3/8	1	4		1		6
13 1/2			3			3
13 1/2		2			1	3
13 5/8	3		1	1		5
13 3/4		5		1		6
13 7/8	1	2	2			5
14			2	1		3
14 1/8	3				1	4
14 1/4		3	2			5
14 3/8	1	2	1	1		5
14 1/2			1		1	2
14 5/8	1	5	1			7
14 3/4		3	1	1		5
14 7/8	1		3			4
14 7/8	1	2			1	4
15				1	1	2
15 1/8	1	5		1		7
15 1/4		1	3			4
15 1/4		3			1	4
15 3/8	1		2	1		4
15 1/2	4				1	5
15 5/8	1	3	2			6
15 3/4		1	2	1		4
15 7/8	1		1		1	3
16		4	2			6

16 1/8	1	3	1	1		6
16 1/4		1	1		1	3
16 3/8	1			1	1	3
16 1/2		4	1	1		6
16 5/8	1	1	3			5
16 5/8	1	3			1	5
16 3/4		1		1	1	3
16 7/8	5				1	6
17		4			1	4
17 1/8	1	1	2	1		5
17 1/4	2		1		1	4
17 3/8	1	4	2			7
17 1/2		2	2	1		5
17 5/8	1	1	1		1	4
17 3/4	2			1	1	4
17 7/8	1	4	1	1		7
18			4			4
18		2	1		1	4
18 1/8	1	1		1	1	4
18 1/4		5	1	1		7
18 1/4	6				1	7
18 3/8	1	2	3			6
18 3/8	1	4			1	6
18 1/2			3	1		4
18 1/2		2		1	1	4
18 5/8	3		1		1	5
18 3/4		3	3			6
18 3/4		5			1	6
18 7/8	1	2	2	1		6
19			2		1	3
19 1/8	3			1	1	5
19 1/4		3	2	1		6
19 3/8	1		4			5
19 3/8	1	2	1		1	5
19 1/2			1	1	1	3
19 5/8	1	5	1	1		8
19 5/8	7				1	8
19 3/4		1	4			5
19 3/4		3	1		1	5
19 7/8	1		3	1		5
19 7/8	1	2		1	1	5
20					2	2