

250-316 SAE NET HORSEPOWER



JOHN DEERE

J

LOADERS

724J | 744J | 824J



Make a big production out of everything.

Unmatched stability, the smoothest ride on the jobsite, and impressive loading performance in tough materials — the 724J, 744J, and 824J Loaders deliver everything you want in a production-class loader. Each is brimming with productivity and uptime-boosting advantages, including

a smooth-as-silk Smart-Shift™ transmission, high-torque turbocharged Deere diesel, and state-of-the-art multi-function monitor with advanced diagnostics. That's just for starters. Read on to learn all the ways the J-Series Loaders will help make a big production out of your operation.



724J

250 horsepower (186 kW)

33,079-lb. tipping load

27,763-lb. 40-degree full-turn tipping load

31,742-lb. breakout

40,704-lb. operating weight

PowerTech™ engines deliver torque reserves that top out at a whopping 54 percent in the 824J. Plus, these turbocharged diesels have a built-in Power Bulge that generates additional horsepower when the rpms drop. It's a John Deere advantage that helps deliver good boom and bucket speed going into the pile, for big bucket loads, even in wet or hard-packed materials.

All three loaders ride on a wide stance that provides additional lateral stability for handling heavy loads and work on uneven terrain.

Low center of gravity and optimized fore-and-aft balance deliver unmatched stability and impressive full-turn tipping load capacities.

Superior combined powertrain and hydraulic performance enables the J-Series to maintain quick ground speeds and boom lift, even on steep ramps. For faster trips from pile to hopper.

Same-side ground-level service access makes the daily routine quick and easy.

824J

316 horsepower (236 kW)
43,523-lb. tipping load
35,708-lb. 40-degree full-turn tipping load
42,916-lb. breakout
57,374-lb. operating weight



744J

288 horsepower (215 kW)
38,978-lb. tipping load
32,839-lb. 40-degree full-turn tipping load
44,526-lb. breakout
51,467-lb. operating weight

Deluxe air-suspension armchair seat adjusts multiple ways for daylong comfort and support.

Automotive-style directional louvers including two directed at the pedals and independently adjustable defrosters provide effective airflow to help keep the glass clear and the pressurized cab comfortable.

Spacious cab provides plenty of room to store your stuff with a compartment for a cooler, beverage holders, and a 12-volt power port for cell-phone hookup.



1

1. Platforms, handrails, and steps are designed to allow uninterrupted three-point access. Continuous railings run all around the machine. Unlike other loaders, there are no crossbars, decreasing the risk of slipping.

2. An advanced, multi-language monitor with analog gauges and LED indicators provides:

- **Detailed diagnostic readings** of most sensors and switches for quick troubleshooting.
- **Vital and general operating information** including transmission mode, gear, engine rpms, and ground speed.
- **Customized machine settings** that allow the operator to match operating characteristics to specific applications by preselecting transmission functions such as Quick Shift and Auto-to-1st for maximum productivity.



2

3. Floor-to-ceiling front glass and expansive side and rear windows allow an unmatched panoramic view ahead, beside, and behind you.



3





Comfort. Able.

From the programmable electronic controls that allow customized machine operation, to a comfortable fully adjustable air-suspension armchair seat, these loaders have everything your operators need to do their best. All-around visibility is virtually

unobstructed, and an efficient HVAC system keeps the view clear, the cab comfortable. Up-front, a state-of-the-art multi-function monitor with easy-to-read messaging, large analog gauges, and LED warning lights provides vital operating info at a glance.



Maximum productivity is at your fingertips.

Top productivity is within easy reach on a John Deere J-Series Loader. Short-throw levers provide low-effort control of the excavator-style hydraulics. The closed-center system senses the load and delivers the power needed for smooth boom and bucket functions and fast cycles.

You won't find a smoother shifting loader, either. The PowerShift™ torque-converter transmission employs Smart-Shift™ technology to continuously evaluate speed and load conditions, and adjusts clutch-pack engagement to suit, for maximum productivity with minimum effort.



Smart-Shift™ technology ensures that gear changes are smooth-as-silk regardless of whether the bucket is empty or fully loaded.

Spin control boosts productivity by improving traction in troublesome material or underfoot conditions. Reduces tire wear, fuel costs, and operator fatigue, too.

Responsive steering combined with full 80-degree articulation provides exceptional maneuverability in tight quarters, for faster cycle times.

Closed-center hydraulic system delivers only the power required, so there's no wasted horsepower or fuel.

Programmable clutch cutoff increases productivity in all kinds of terrain. It allows you to select the braking force that best matches the slope at your dumpsite — level, small, or steep. When the brake pedal is depressed, the transmission disconnects while keeping engine speed high for smoother dumps and faster cycles.

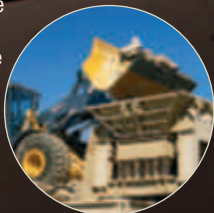

Boom height kick-out sets maximum desired dump height, while **return-to-carry** predetermines the lowered boom position — perfect for repetitive loading applications.



1. Pilot-operated controls are comfortable to operate and incorporate John Deere's innovative Quick-Shift feature for convenient fingertip gear changes. Single-lever option employs a finger-operated F-N-R switch and top-of-the-grip pushbuttons for one-hand boom, bucket, ground speed, and forward/reverse control.

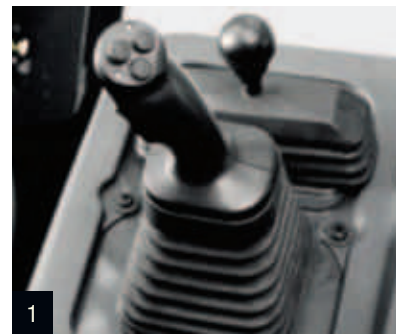

2. Backlit pushbuttons in the sealed switch module allow fingertip control of various functions. What's more, no more tools are required to adjust boom height kick-out and return-to-carry. Instead, the operator can set these from the seat, for more uptime and productivity.

2



Self-adjusting wet-disc brakes are mounted inboard where they run cool, clean, and unexposed to corrosive materials. Brake lines are equally protected.

Standard features such as automatic park brake, bypass-start protection, continuous handrails, and wide slip-resistant steps and platforms help keep the operator out of harm's way.

Wet-sleeve liners provide uniform cooling for reduced ring wear and oil breakdown — and longer engine life.

Large-capacity, quick-to-fill fuel tanks let you run longer for more uptime and productivity.

Steering cylinders are well-protected, yet readily accessible within the loader and engine frame.



1

1. Electrical distribution center employs extremely reliable circuit-board technology and solid-state switches, eliminating the need for a multitude of wiring harnesses, fuses, relays, and connectors.



2

2. Four steel plates support the far end of the boom pivot, extending pin life while protecting the boom cylinder hoses.



3

3. Planetary final drives are mounted inboard. Since gear size isn't limited by wheel hub diameter, larger, more durable components are utilized.



4

4. Radiators and coolers are mounted side-by-side for efficient cooling and quicker clean-out.





Built to the hilt.

Uptime isn't everything. It's the only thing. And the reason we loaded these loaders with durability features such as solid-state electrical distribution centers, advanced diagnostic monitors, and extended service intervals. Your bottom line will also benefit

from wet-sleeve engine cylinder liners, inboard planetary axles with self-adjusting wet-disc brakes, and booms and main-frames so tough they're warranted for three years or 10,000 hours. When you know how they're built, you'll run a Deere.



The right stuff.

J-Series Loaders are capable of handling almost anything. But if yours isn't just any application, we've got you covered. Choose from a wide variety of factory-installed options to fit your needs. From

high-lift booms to purpose-built waste handlers to corrosion-protection packages, John Deere can equip your 724J, 744J, or 824J with exactly what you need to be productive in your kind of work.



Axle options include front differential lock with conventional rear and front and rear differential locks.

Corrosion package shields electrical components and connections for longer life — so corrosion won't short-circuit productivity.

With their unique reversible and interchangeable design, Jagz™ edges allow you to easily custom-build a bucket cutting edge. What's more, they're self-sharpening and guaranteed against breakage.

Advanced air-screen kits protect the engine and cooling system from debris while increasing airflow and preventing overheating.

High-lift loaders feature an optional, factory-installed boom that extends reach by 14 to 22 inches so you can move materials — and push productivity — to even greater heights.

Fire-resistant hydraulic fluids are available for added protection in extreme temperature conditions.



1

1. 724J and 744J Waste Handlers deliver the same excellent performance as our standard loaders, but with extra guarding, cooling, and other purpose-built features designed to withstand harsh environments.

2. Fender extenders and flaps keep mud and debris off the cab windows and articulation areas.

3. Onboard weighing systems enable you to load each truck to its full legal payload for maximum productivity.

4. Choose either single-lever joystick or two-lever fingertip control. Add up to three extra hydraulic functions.

5. Ride-control option cushions the ride, so the loader can travel more quickly without losing its load.



2



3



5



4

Large hinged service doors swing open, easily providing ample ground-level access. A convenient service and lubrication chart provides a quick reference that helps ensure that no maintenance gets overlooked.

Large-capacity fuel tanks have filler necks that accommodate up to 60 gpm, for fast ground-level fueling.

No stacked coolers back here. Their side-by-side positioning makes the radiator, hydraulic cooler, transmission cooler, and air conditioner condenser easy to inspect, easy to clean.

No breathers to check, no exposed brake lines to replace — the J-Series' inboard planetary final drives and wet-disc brakes are virtually maintenance free.

Maintenance personnel will appreciate the commonsense locations and ease with which power-train, hydraulic, and cab filters are replaced.



The bucks stop here.

We're always looking for ways to reduce your daily operating costs. And you won't have to look far to see the results of our efforts. Large hinged side shields swing open easily, providing spacious ground-level access. Same-side service points are

conveniently grouped and clearly visible to make quick work of the daily routine. And easy-to-read sight gauges, extended service intervals, and advanced self-diagnostics help keep daily and periodic maintenance manageable.

1. Daily service points are grouped on the same side for quick and convenient ground-level access.

4. Greasing is less messy with centralized lube banks providing easy access to difficult-to-reach zerks.

2. Sight gauges and coolant reservoir let you check transmission, hydraulic, and radiator fluid levels at a glance.

5. Vertical spin-on engine, transmission, and hydraulic filters; quick-release fuel filters; and environmentally friendly engine oil drain allow quick, no-spill changes.

3. If something goes wrong, the advanced monitor provides easy-to-understand diagnostic information to help you get back up and running more quickly.

6. Your John Deere dealer has the parts and service you need to stay productive, and offers a wide variety of preventative maintenance and support programs to help control costs.



Specifications



Engine 724J

Type	John Deere POWERTECH™ 6081H; meets EPA Tier II non-road emissions regulations
Cylinders	6
Valves Per Cylinder	2
Displacement	496 cu. in. (8.1 L)
Net Peak Power	250 hp (186 kW) @ 1,800 rpm
Net Rated Power	215 hp (160 kW) @ 2,200 rpm
Net Peak Torque	765 lb.-ft. (1040 Nm) @ 1,300 rpm
Net Torque Rise	49%
Net Power Bulge	16%
Fuel System	high-pressure common rail
Lube System	full-flow spin-on filter and integral cooler
Aspiration	turbocharged, charge air cooled
Air Cleaner	dual element dry type; restriction indicator in cab monitor for service
Fan Drive	hydraulically driven, proportionally controlled, fan aft of coolers
Electrical System	24 volt with 80-amp alternator
Batteries (two 12 volt)	1,400 CCA; reserve capacity: 200 min.

Transmission

Type	countershaft-type power shift	
Torque Converter	single stage, single phase	
Shift Control	electronically modulated, adaptive, load and speed dependent	
Operator Interface	steering column-mounted twist-grip shift lever, quick-shift button on hydraulic lever	
Shift Modes	auto/manual, auto to 1st or 2nd, kick down or kick up/down, three clutch cutoff settings	
Travel Speeds*	<i>Forward</i>	<i>Reverse</i>
Gear 1	4.6 mph (7.4 km/h)	4.9 mph (7.9 km/h)
Gear 2	7.6 mph (12.2 km/h)	8.0 mph (12.8 km/h)
Gear 3	14.7 mph (23.6 km/h)	15.5 mph (24.9 km/h)
Gear 4	22.0 mph (35.4 km/h)	

*Equipped with 23.5 R 25 tires.

Axles/Brakes

Final Drives	heavy-duty inboard planetary
Differentials*	hydraulic locking front, conventional rear — standard; dual locking front and rear — optional
Rear Axle Oscillation, Stop to Stop**	26 degrees
Brakes (conform to SAE J1473, ISO3450)	
Service Brakes	hydraulically actuated, inboard, carrier mounted, pressure oil cooled, self adjusting, multi disc
Parking Brake	automatically spring applied, hydraulically released, oil cooled, multi disc

*Contact dealer for information regarding limited slip and conventional front and rear availability.

**Equipped with 23.5 R 25 tires.

Tires

Choice of (with five-piece rims)	Tread Width	Width Over Tires	Change In Vertical Height
23.5-25, 20 PR L3	85.4 in. (2170 mm)	113.4 in. (2880 mm)	- 0.1 in. (- 3 mm)
28L-26, 14 PR LS2 [†]	89.4 in. (2272 mm)	117.6 in. (2987 mm)	+ 0.4 in. (+ 10 mm)
23.5 R 25, 1-Star L2 Radial	85.4 in. (2170 mm)	113.2 in. (2875 mm)	0 in. (0 mm)
23.5 R 25, 1-Star L3 Radial	85.4 in. (2170 mm)	109.1 in. (2771 mm)	+ 1.2 in. (+ 30 mm)
750/65 R 25, 1-Star L3-T Radial*	86.8 in. (2204 mm)	120.7 in. (3066 mm)	- 0.3 in. (- 8 mm)

*Requires 9-degree rear axle stops.

[†]With single-piece rims.

Refill Capacities (U.S.)

Fuel Tank (with ground-level fueling)	100 gal. (379 L)
Cooling System	32 qt. (31 L)
Engine Lubrication, Including Vertical Spin-	
On Filter	26 qt. (25 L)
Powershift Transmission, Including Filter	27 qt. (26 L)
Differential (front and rear, each axle)	30 qt. (29 L)
Loader Hydraulic Reservoir and Filters	31 gal. (118 L)
Sealed Wet-Disc Parking Brake	20 oz. (600 mL)

Hydraulic System/Steering

724J

Pump (loader and steering)	variable-displacement, axial piston pump; closed-center, pressure-compensating system	
Maximum Flow @ 2,200 rpm	74 gpm (280 L/min.) @ 1,000 psi (6895 kPa)	
Pressure	loader and steering relief 3,600 psi (24 850 kPa)	
Loader Controls	two-function valve; single- and dual-lever controls; control lever lockout feature; optional third- and fourth-function valve with auxiliary lever	
Steering (conforms to SAE J1511)		
Type	power, fully hydraulic	
Pressure	3,600 psi (24 850 kPa) relief	
Articulation Angle	80-degree arc (40 degrees each direction)	
Hydraulic Cycle Times	<i>Standard Z-Bar</i>	<i>High-Lift Z-Bar</i>
Raise	6.0 sec.	6.2 sec.
Dump	1.2 sec.	1.4 sec.
Lower	3.0 sec. (float down)	3.0 sec. (float down)
Total	10.2 sec.	10.6 sec.
Maximum Lift Capacity	<i>with 4.75-cu.-yd. (3.6 m³) general-purpose bucket with bolt-on cutting edge</i>	<i>with 4.25-cu.-yd. (3.3 m³) general-purpose bucket with bolt-on cutting edge</i>
Lift at Ground Level	30,881 lb. (14 005 kg)	30,764 lb. (13 952 kg)
Lift at Maximum Height	19,830 lb. (8993 kg)	16,899 lb. (7664 kg)
Turning Radius (measured to centerline of outside tire)	18 ft. 0 in. (5500 mm)	18 ft. 0 in. (5500 mm)

Dimensions with Pin-On Bucket

	<i>Standard Z-Bar</i>	<i>High-Lift Z-Bar</i>
A Height to Top of Cab and Canopy	11 ft. 2 in. (3412 mm)	11 ft. 2 in. (3412 mm)
B Height to Top of Exhaust	11 ft. 0 in. (3362 mm)	11 ft. 0 in. (3362 mm)
C Ground Clearance	17.8 in. (453 mm)	17.8 in. (453 mm)
D Length from Centerline to Front Axle	63 in. (1600 mm)	63 in. (1600 mm)
E Wheelbase	126 in. (3200 mm)	126 in. (3200 mm)
F Dump Height	▲ (see page 17)	▲ (see page 18)
G Height to Hinge Pin, Fully Raised	13 ft. 7 in. (4136 mm)	15 ft. 0 in. (4562 mm)
H Dump Reach	▲▲ (see page 17)	▲▲ (see page 18)
I Maximum Digging Depth	2.8 in. (71 mm)	6.7 in. (169 mm)
J Overall Length	▲▲▲ (see page 17)	▲▲▲ (see page 18)
K Maximum Rollback at Ground Level	40 degrees	40 degrees

724J LOADER WITH PIN-ON BUCKET

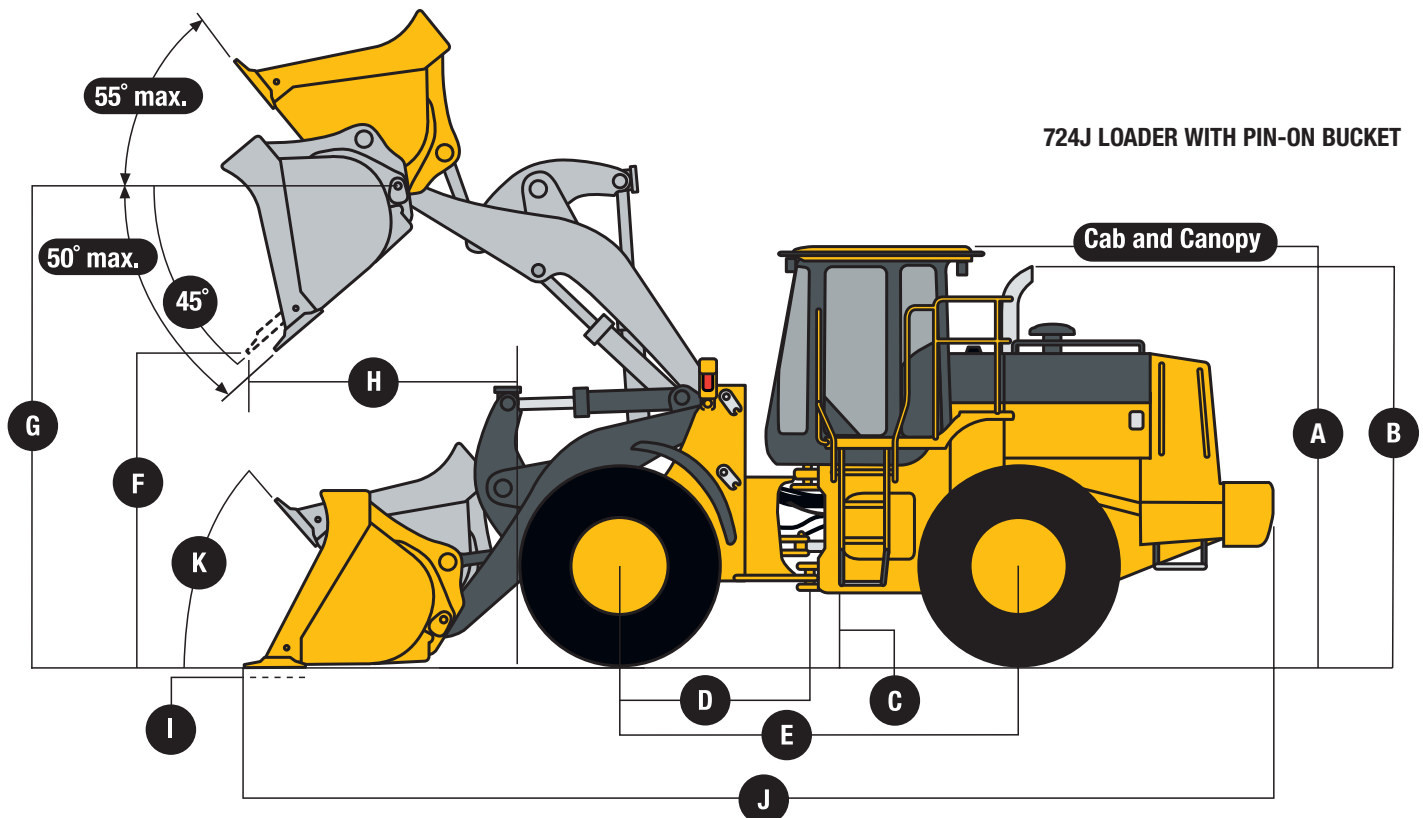

Dimensions with Quick-Coupler and Bucket

724J

- A** Dump Clearance ▲ (see page 17)
- B** Dump Reach ▲▲ (see page 17)
- C** Maximum Digging Depth 2.8 in. (71 mm)
- D** Height to Hinge Pin, Fully Raised 13 ft. 7 in. (4136 mm)
- E** Overall Length ▲▲▲ (see page 17)
- F** Maximum Rollback, Boom Fully Raised 55 degrees
- G** Maximum Bucket Discharge Angle, Fully Raised 45 degrees
- H** Maximum Rollback at Ground Level 39 degrees

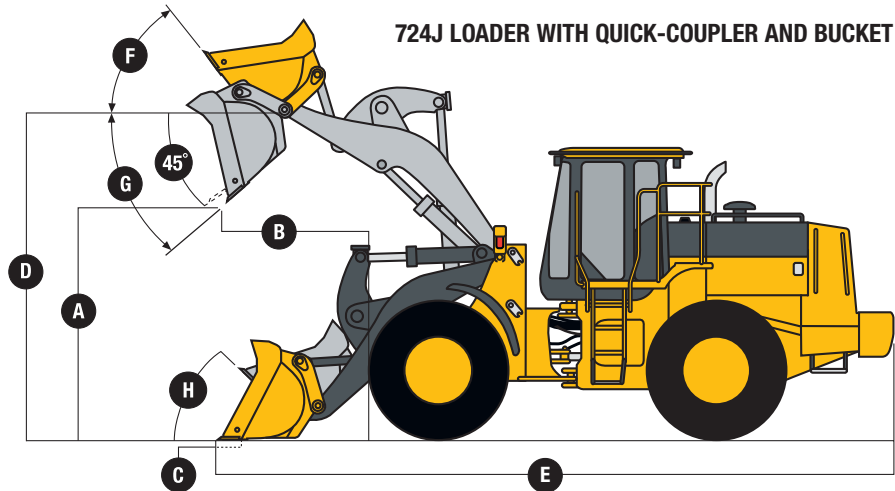

724J LOADER WITH QUICK-COUPLER AND BUCKET

Dimensions with Quick-Coupler and Construction Fork

724J

- A** Reach, Fully Raised 2 ft. 5 in. (732 mm)
- B** Fork Height, Fully Raised 12 ft. 7 in. (3845 mm)
- C** Maximum Reach, Fork Level 5 ft. 4 in. (1627 mm)
- D** Fork Height, Maximum Reach 5 ft. 9 in. (1764 mm)
- E** Reach, Ground Level 3 ft. 4 in. (1021 mm)
- F** Depth Below Ground 1.4 in. (35 mm)
- G** Tine Length 72 in. (1829 mm)
- H** Overall Length 29 ft. 6 in. (8982 mm)

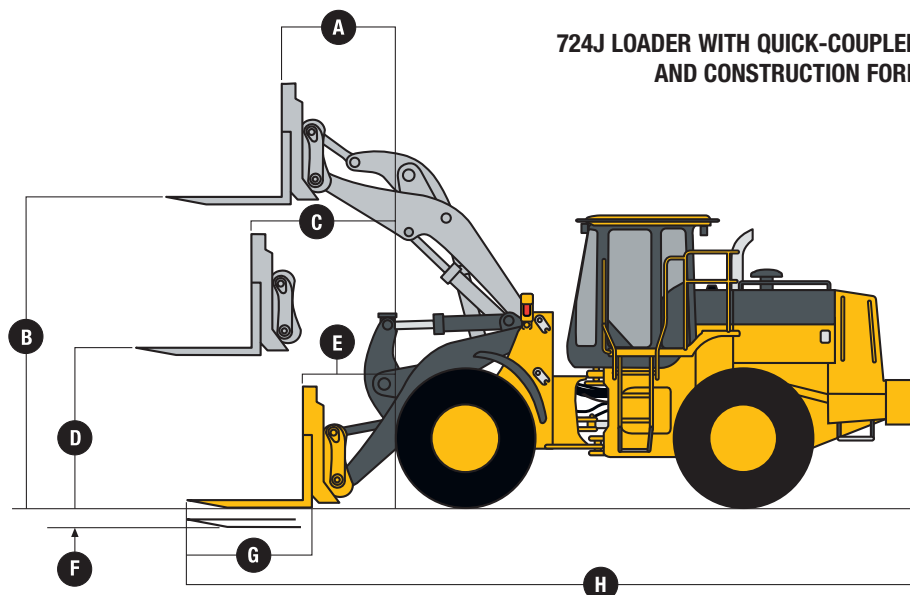

724J LOADER WITH QUICK-COUPLER AND CONSTRUCTION FORK

**Standard Z-Bar Information
with Pin-On Type Bucket**

724J

	<i>General Purpose w/Bolt-on Edge</i>	<i>General Purpose w/Teeth & Segments</i>	<i>General Purpose w/Jagz™</i>	<i>General Purpose w/Bolt-on Edge</i>	<i>General Purpose w/Teeth & Segments</i>
Bucket Type/Size					
Capacity, Heaped SAE	4.75 cu. yd. (3.6 m³)	4.75 cu. yd. (3.6 m³)	4.75 cu. yd. (3.6 m³)	4.5 cu. yd. (3.4 m³)	4.25 cu. yd. (3.3 m³)
Capacity, Struck SAE	4.2 cu. yd. (3.2 m³)	4.2 cu. yd. (3.2 m³)	4.2 cu. yd. (3.2 m³)	3.8 cu. yd. (2.9 m³)	3.7 cu. yd. (2.8 m³)
Bucket Weight	4,006 lb. (1817 kg)	4,112 lb. (1865 kg)	4,108 lb. (1863 kg)	3,709 lb. (1682 kg)	3,682 lb. (1670 kg)
Bucket Width	119.0 in. (3040 mm)	119.0 in. (3040 mm)	119.0 in. (3040 mm)	119.7 in. (3040 mm)	114.2 in. (2900 mm)
Breakout Force, SAE J732C	31,742 lb. (14 398 kg)	31,742 lb. (14 398 kg)	31,440 lb. (14 261 kg)	34,340 lb. (15 576 kg)	34,407 lb. (15 604 kg)
Tipping Load, Straight	33,079 lb. (15 002 kg)	32,978 lb. (14 956 kg)	33,340 lb. (15 120 kg)	33,767 lb. (15 314 kg)	33,721 lb. (15 293 kg)
Tipping Load, 40-Degree Full Turn, SAE	27,763 lb. (12 591 kg)	27,664 lb. (12 546 kg)	27,973 lb. (12 686 kg)	28,389 lb. (12 875 kg)	28,343 lb. (12 854 kg)
Reach, 45-Degree Dump, 7-ft. (2.13 m) Clearance	67.6 in. (1718 mm)	70.1 in. (1780 mm)	61.3 in. (1558 mm)	65.7 in. (1668 mm)	67.6 in. (1718 mm)
▲▲ Reach, 45-Degree Dump, Full Height	45.4 in. (1152 mm)	49.9 in. (1267 mm)	41.1 in. (1045 mm)	42.2 in. (1072 mm)	46.2 in. (1174 mm)
▲ Dump Clearance, 45 Degree, Full Height	113.5 in. (2883 mm)	109.7 in. (2786 mm)	109.7 in. (2786 mm)	115.8 in. (2942 mm)	111.9 in. (2841 mm)
▲▲▲ Overall Length, Bucket on Ground	26 ft. 11 in. (8195 mm)	27 ft. 5 in. (8345 mm)	27 ft. 0 in. (8215 mm)	26 ft. 7 in. (8100 mm)	27 ft. 1 in. (8253 mm)
Loader Clearance Circle, Bucket In Carry Position	42 ft. 10 in. (13 067 mm)	43 ft. 2 in. (13 160 mm)	42 ft. 11 in. (13 080 mm)	42 ft. 8 in. (13 010 mm)	42 ft. 7 in. (12 978 mm)
Operating Weight	40,704 lb. (18 460 kg)	40,810 lb. (18 508 kg)	40,806 lb. (18 506 kg)	40,360 lb. (18 304 kg)	40,380 lb. (18 313 kg)

Loader operating information is based on machine with all standard equipment; 23.5 R 25, 1-Star L2 Radial tires; ROPS/FOPS cab; 175-lb. (79 kg) operator; and full fuel tank. This information is affected by tire size, ballast, and different attachments.

Adjustments to Operating Weights for Standard Z-Bar with Pin-On Type Buckets

Adjustments to operating weights and tipping loads based on standard boom and 4.75-cu.-yd. (3.6 m³) general-purpose bucket with bolt-on cutting edge

Add (+) or deduct (-) lb. (kg) as indicated

	<i>Operating Weight</i>	<i>Tipping Load, Straight</i>	<i>Tipping Load, 40-Degree Full Turn, SAE</i>
for loaders with			
23.5-25, 20 PR L3	- 309 lb. (- 140 kg)	- 213 lb. (- 97 kg)	- 182 lb. (- 83 kg)
28L-26, 14 PR LS2 [†]	+ 88 lb. (+ 40 kg)	+ 61 lb. (+ 28 kg)	+ 52 lb. (+ 24 kg)
23.5 R 25, 1-Star L2 Radial	0 lb. (0 kg)	0 lb. (0 kg)	0 lb. (0 kg)
23.5 R 25, 1-Star L3 Radial	+ 928 lb. (+ 421 kg)	+ 641 lb. (+ 290 kg)	+ 548 lb. (+ 248 kg)
750/65 R 25, 1-Star L3-T Radial*	+ 983 lb. (+ 446 kg)	+ 679 lb. (+ 308 kg)	+ 580 lb. (+ 263 kg)

*Requires 9-degree rear axle stops.

†With single-piece rims.

Standard Z-Bar Information with Quick-Coupler and Bucket

	<i>General Purpose w/Bolt-on Edge</i>	<i>General Purpose w/Bolt-on Edge</i>
Bucket Type/Size		
Capacity, Heaped SAE	4.5 cu. yd. (3.4 m³)	4.0 cu. yd. (3.06 m³)
Capacity, Struck SAE	3.8 cu. yd. (2.9 m³)	3.2 cu. yd. (2.5 m³)
Bucket Weight with Coupler	4,456 lb. (2021 kg)	3,890 lb. (1764 kg)
Bucket Width	114.2 in. (2900 mm)	114.2 in. (2900 mm)
Breakout Force, SAE J732C	28,795 lb. (13 059 kg)	32,019 lb. (14 521 kg)
Tipping Load, Straight	33,126 lb. (15 023 kg)	34,197 lb. (15 509 kg)
Tipping Load, 40-Degree Full Turn, SAE	27,781 lb. (12 599 kg)	28,758 lb. (13 042 kg)
Reach, 45-Degree Dump, 7-ft. (2.13 m) Clearance	63.0 in. (1601 mm)	67.6 in. (1718 mm)
▲▲ Reach, 45-Degree Dump, Full Height	44.8 in. (1137 mm)	45.3 in. (1151 mm)
▲ Dump Clearance, 45 Degree, Full Height	106.4 in. (2703 mm)	113.5 in. (2883 mm)
▲▲▲ Overall Length, Bucket on Ground	27 ft. 4 in. (8334 mm)	26 ft. 11 in. (8194 mm)
Loader Clearance Circle, Bucket In Carry Position	42 ft. 9 in. (13 027 mm)	42 ft. 5 in. (12 940 mm)
Operating Weight	41,154 lb. (18 664 kg)	40,587 lb. (18 407 kg)

Loader operating information is based on machine with all standard equipment; 23.5 R 25, 1-Star L2 Radial tires; ROPS/FOPS cab; 175-lb. (79 kg) operator; and full fuel tank. This information is affected by tire size, ballast, and different attachments.

Standard Z-Bar Information with Quick-Coupler and Construction Fork 724J

Tine Length	72 in. (1829 mm)
Overall Length	29 ft. 6 in. (8982 mm)
Tipping Load, Straight (fork level, load centered 36-in. [914 mm] on tine)	24,446 lb. (11 809 kg)
Tipping Load, 40-Degree Full Turn (fork level, load centered 36-in. [914 mm] on tine)	20,543 lb. (9318 kg)
Operating Weight	40,426 lb. (18 334 kg)

High-Lift Z-Bar Information with Pin-On Type Bucket

	<i>General Purpose w/Bolt-on Edge</i>
Bucket Type/Size	
Capacity, Heaped SAE	4.25 cu. yd. (3.3 m ³)
Capacity, Struck SAE	3.7 cu. yd. (2.8 m ³)
Bucket Weight	3,555 lb. (1612 kg)
Bucket Width	114.2 in. (2900 mm)
Breakout Force, SAE J732C	30,610 lb. (13 882 kg)
Tipping Load, Straight	27,432 lb. (12 441 kg)
Tipping Load, 40-Degree Full Turn, SAE	22,974 lb. (10 419 kg)
Reach, 45-Degree Dump, 7-ft. (2.13 m) Clearance	82.8 in. (2103 mm)
▲▲ Reach, 45-Degree Dump, Full Height	46.8 in. (1188 mm)
▲ Dump Clearance, 45 Degree, Full Height	132.6 in. (3368 mm)
▲▲▲ Overall Length, Bucket on Ground	28 ft. 2 in. (8579 mm)
Loader Clearance Circle, Bucket In Carry Position	43 ft. 9 in. (13 323 mm)
Operating Weight	40,671 lb. (18 445 kg)

Loader operating information is based on machine with all standard equipment; 23.5 R 25, 1-Star L2 Radial tires; ROPS/FOPS cab; 175-lb. (79 kg) operator; and full fuel tank. This information is affected by tire size, ballast, and different attachments.

Bucket Selection Guides*

724J Z-Bar Pin-On Bucket Selection Guide

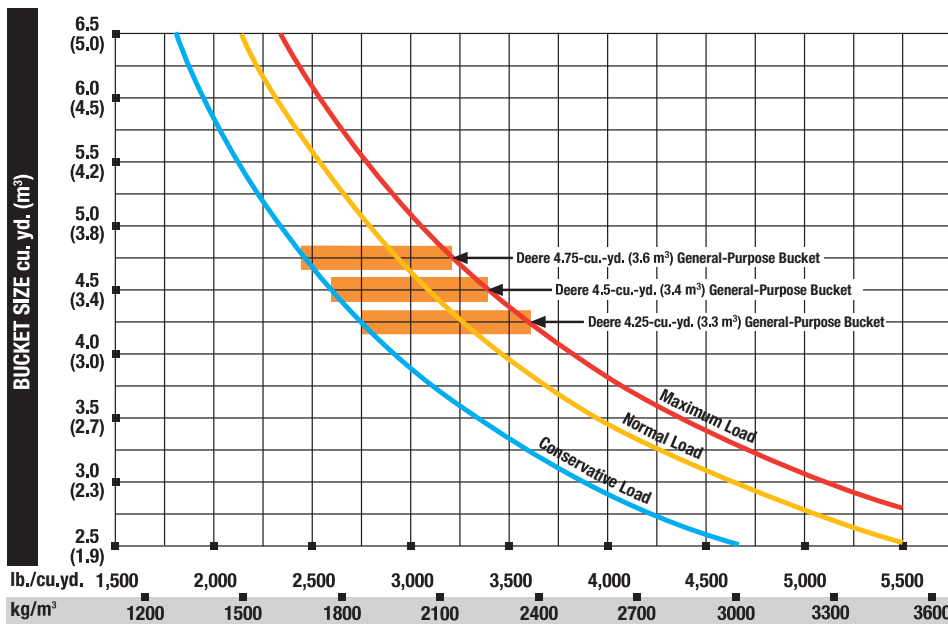

MATERIAL (Loose weight)	lb./cu. yd.	kg/m ³
Caliche	2,100	1250
Cinders	1,000	590
Clay and gravel, dry	2,400	1420
Clay and gravel, wet	2,600	1540
Clay, dry	2,500	1480
Clay, natural bed	2,800	1660
Clay, wet	2,800	1660
Coal, anthracite, broken	1,850	1100
Coal, bituminous, broken	1,400	830
Earth, dry, packed	2,550	1510
Earth, loam	2,100	1250
Earth, wet, excavated	2,700	1600
Granite, broken or large crushed	2,800	1660
Gravel, dry	2,550	1510
Gravel, dry 1/2" to 2" (13 to 50 mm)	2,850	1690
Gravel, pit run (graveled sand)	3,250	1930
Gravel, wet 1/2" to 2" (13 to 50 mm)	3,400	2020
Gypsum, crushed	2,700	1600
Limestone, broken or crushed	2,600	1540
Magnetite, iron ore	4,700	2790
Phosphate rock	2,160	1280
Pyrite, iron ore	4,350	2580
Sand and gravel, dry	2,900	1720
Sand and gravel, wet	3,400	2020
Sand, dry	2,400	1420
Sand, wet	3,100	1840
Sandstone, broken	2,550	1510
Shale	2,100	1250
Slag, broken	2,950	1750
Stone, crushed	2,700	1600
Topsoil	1,600	950

* This guide, representing bucket sizes not necessarily manufactured by Deere, will help you in selecting proper bucket size for material density, loader configuration, and operating conditions. Optimum bucket size is determined after adding or subtracting all tipping load changes due to optional equipment. The "conservative load" line on this guide is recommended when operating in conditions such as soft ground and unlevel surfaces. The "maximum load" condition on this guide is sometimes utilized when operating on firm ground and level surfaces.

724J Z-Bar Quick-Coupler Bucket Selection Guide

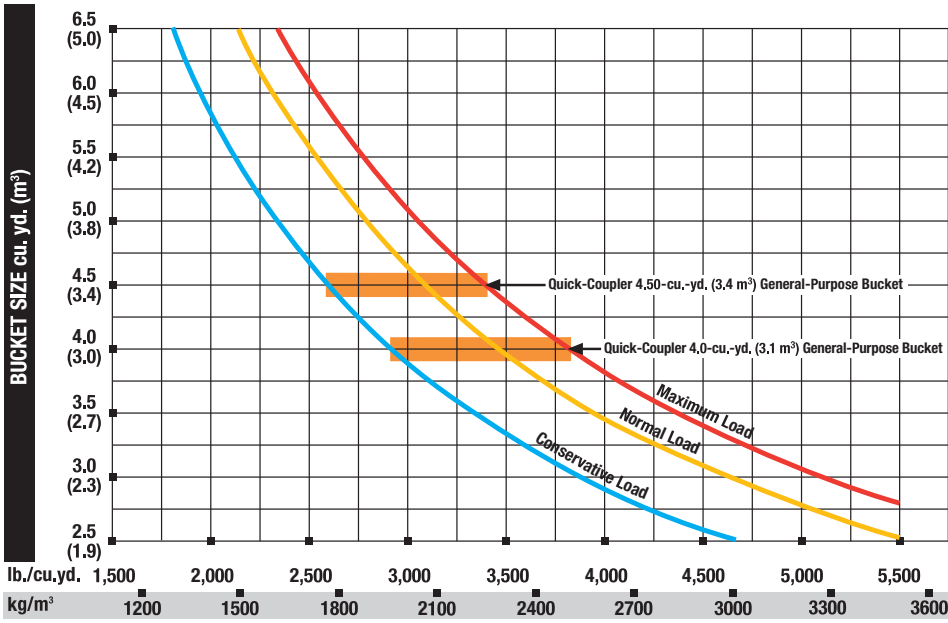

* This guide, representing bucket sizes not necessarily manufactured by Deere, will help you in selecting proper bucket size for material density, loader configuration, and operating conditions. Optimum bucket size is determined after adding or subtracting all tipping load changes due to optional equipment. The "conservative load" line on this guide is recommended when operating in conditions such as soft ground and unlevel surfaces. The "maximum load" condition on this guide is sometimes utilized when operating on firm ground and level surfaces.

MATERIAL (Loose weight)	lb./cu. yd.	kg/m³
Caliche	2,100	1250
Cinders	1,000	590
Clay and gravel, dry	2,400	1420
Clay and gravel, wet	2,600	1540
Clay, dry	2,500	1480
Clay, natural bed	2,800	1660
Clay, wet	2,800	1660
Coal, anthracite, broken	1,850	1100
Coal, bituminous, broken	1,400	830
Earth, dry, packed	2,550	1510
Earth, loam	2,100	1250
Earth, wet, excavated	2,700	1600
Granite, broken or large crushed	2,800	1660
Gravel, dry	2,550	1510
Gravel, dry 1/2" to 2" (13 to 50 mm)	2,850	1690
Gravel, pit run (graveled sand)	3,250	1930
Gravel, wet 1/2" to 2" (13 to 50 mm)	3,400	2020
Gypsum, crushed	2,700	1600
Limestone, broken or crushed	2,600	1540
Magnetite, iron ore	4,700	2790
Phosphate rock	2,160	1280
Pyrite, iron ore	4,350	2580
Sand and gravel, dry	2,900	1720
Sand and gravel, wet	3,400	2020
Sand, dry	2,400	1420
Sand, wet	3,100	1840
Sandstone, broken	2,550	1510
Shale	2,100	1250
Slag, broken	2,950	1750
Stone, crushed	2,700	1600
Topsoil	1,600	950

724J High-Lift Z-Bar Pin-On Bucket Selection Guide

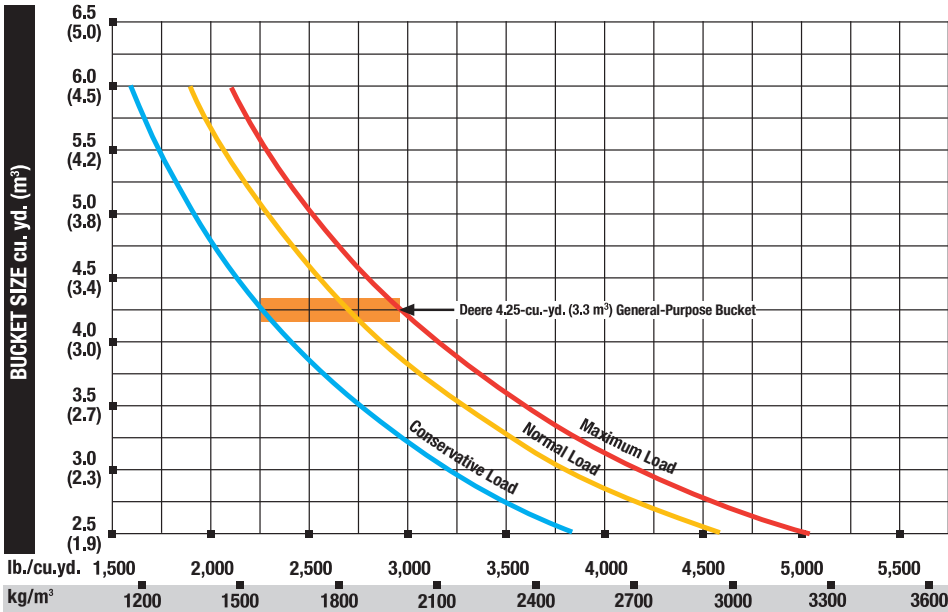

* This guide, representing bucket sizes not necessarily manufactured by Deere, will help you in selecting proper bucket size for material density, loader configuration, and operating conditions. Optimum bucket size is determined after adding or subtracting all tipping load changes due to optional equipment. The "conservative load" line on this guide is recommended when operating in conditions such as soft ground and unlevel surfaces. The "maximum load" condition on this guide is sometimes utilized when operating on firm ground and level surfaces.

MATERIAL (Loose weight)	lb./cu. yd.	kg/m³
Caliche	2,100	1250
Cinders	1,000	590
Clay and gravel, dry	2,400	1420
Clay and gravel, wet	2,600	1540
Clay, dry	2,500	1480
Clay, natural bed	2,800	1660
Clay, wet	2,800	1660
Coal, anthracite, broken	1,850	1100
Coal, bituminous, broken	1,400	830
Earth, dry, packed	2,550	1510
Earth, loam	2,100	1250
Earth, wet, excavated	2,700	1600
Granite, broken or large crushed	2,800	1660
Gravel, dry	2,550	1510
Gravel, dry 1/2" to 2" (13 to 50 mm)	2,850	1690
Gravel, pit run (graveled sand)	3,250	1930
Gravel, wet 1/2" to 2" (13 to 50 mm)	3,400	2020
Gypsum, crushed	2,700	1600
Limestone, broken or crushed	2,600	1540
Magnetite, iron ore	4,700	2790
Phosphate rock	2,160	1280
Pyrite, iron ore	4,350	2580
Sand and gravel, dry	2,900	1720
Sand and gravel, wet	3,400	2020
Sand, dry	2,400	1420
Sand, wet	3,100	1840
Sandstone, broken	2,550	1510
Shale	2,100	1250
Slag, broken	2,950	1750
Stone, crushed	2,700	1600
Topsoil	1,600	950

Specifications

Engine 744J

Type	John Deere POWERTECH™ 6125H; meets EPA Tier II non-road emissions regulations
Cylinders	6
Valves Per Cylinder	4
Displacement	766 cu. in. (12.5 L)
Net Peak Power	288 hp (215 kW) @ 1,800 rpm
Net Rated Power	265 hp (198 kW) @ 2,000 rpm
Net Peak Torque	970 lb.-ft. (1320 Nm) @ 1,100 rpm
Net Torque Rise	40%
Net Power Bulge	8%
Fuel System	mechanically actuated electronic unit injectors
Lube System	full-flow spin-on filter and integral cooler
Aspiration	turbocharged, charge air cooled
Air Cleaner	dual element dry type; restriction indicator in cab monitor for service
Fan Drive	belt driven, fan forward of coolers
Electrical System	24 volt with 80-amp alternator
Batteries (two 12 volt)	1,400 CCA; reserve capacity: 200 min.

Transmission

Type	countershaft-type power shift	
Torque Converter	single stage, dual phase with freewheeling stator	
Shift Control	electronically modulated, adaptive, load and speed dependent	
Operator Interface	steering column-mounted twist-grip shift lever, quick-shift button on hydraulic lever	
Shift Modes	auto/manual, auto to 1st or 2nd, kick down or kick up/down, three clutch cutoff settings	
Travel Speeds*	<i>Forward</i>	<i>Reverse</i>
Gear 1	4.6 mph (7.4 km/h)	4.6 mph (7.4 km/h)
Gear 2	8.6 mph (13.9 km/h)	8.6 mph (13.9 km/h)
Gear 3	13.1 mph (21.2 km/h)	19.3 mph (31.0 km/h)
Gear 4	24.5 mph (39.5 km/h)	

*Equipped with 26.5 R 25 tires.

Axles/Brakes

Final Drives	heavy-duty inboard planetary
Differentials*	hydraulic locking front, conventional rear — standard; dual locking front and rear — optional
Rear Axle Oscillation, Stop to Stop**	26 degrees
Brakes (conform to SAE J1473, ISO3450)	
Service Brakes	hydraulically actuated, inboard, sun gear mounted, oil cooled, self adjusting, single disc
Parking Brake	automatically spring applied, hydraulically released, oil cooled, multi disc

*Contact dealer for information regarding limited slip and conventional front and rear availability.

**Equipped with 26.5 R 25 tires.

Tires

Choice of (with five-piece rims)	Tread Width	Width Over Tires	Change In Vertical Height
26.5-25, 20 PR L3	86.6 in. (2200 mm)	116.0 in. (2946 mm)	+ 0.7 in. (+ 18 mm)
26.5-25, 20 PR L5*	86.6 in. (2200 mm)	115.8 in. (2941 mm)	+ 3.9 in. (+ 98 mm)
26.5 R 25, 1-Star L3 Radial	86.6 in. (2200 mm)	115.6 in. (2936 mm)	0 in. (0 mm)
29.5 R 25, 1-Star L3 Radial*	86.6 in. (2200 mm)	118.6 in. (3012 mm)	+ 2.2 in. (+ 57 mm)

*Requires 8-degree rear axle stops, close-mounted steps, and no fenders.

Refill Capacities (U.S.)

Fuel Tank (with ground-level fueling)	122 gal. (462 L)
Cooling System	40 qt. (38 L)
Engine Lubrication, Including Vertical Spin-	
On Filter	40 qt. (38 L)
Powershift Transmission, Including Filter	30 qt. (28 L)
Differential (front and rear, each axle)	49 qt. (46 L)
Loader Hydraulic Reservoir and Filters	38 gal. (144 L)
Sealed Wet-Disc Parking Brake	20 oz. (600 mL)

Hydraulic System/Steering

744J

Pump (loader and steering)	two variable-displacement, load-sensing axial piston pumps; closed-center system	
Maximum Flow @ 2,250 rpm	104 gpm (393 L/min.) @ 1,000 psi (6895 kPa)	
Pressure	loader and steering relief 3,200 psi (22 000 kPa)	
Loader Controls	two-function valve; single- and dual-lever controls; control lever lockout feature; optional third- and fourth-function valve with auxiliary lever	
Steering (conforms to SAE J1511)		
Type	power, fully hydraulic	
Pressure	3,200 psi (22 000 kPa) relief	
Articulation Angle	80-degree arc (40 degrees each direction)	
Hydraulic Cycle Times	<i>Standard Z-Bar</i>	<i>High-Lift Z-Bar</i>
Raise	6.5 sec.	6.6 sec.
Dump	1.5 sec.	1.5 sec.
Lower	3.0 sec. (float down)	3.0 sec. (float down)
Total	11.0 sec.	11.1 sec.
	<i>with 5.25-cu.-yd. (4.0 m³) general-purpose bucket with bolt-on cutting edge</i>	<i>with 4.50-cu.-yd. (3.4 m³) general-purpose bucket with bolt-on cutting edge</i>
Maximum Lift Capacity		
Lift at Ground Level	45,469 lb. (20 621 kg)	39,353 lb. (17 847 kg)
Lift at Maximum Height	25,439 lb. (11 537 kg)	23,212 lb. (10 522 kg)
Turning Radius (measured to centerline of outside tire)	20 ft. 2 in. (6140 mm)	20 ft. 2 in. (6140 mm)

Dimensions with Pin-On Bucket

	<i>Standard Z-Bar</i>	<i>High-Lift Z-Bar</i>
A Height to Top of Cab and Canopy	11 ft. 7 in. (3520 mm)	11 ft. 7 in. (3520 mm)
B Height to Top of Exhaust	10 ft. 2 in. (3100 mm)	10 ft. 2 in. (3100 mm)
C Ground Clearance	18.3 in. (465 mm)	18.3 in. (465 mm)
D Length from Centerline to Front Axle	67 in. (1700 mm)	67 in. (1700 mm)
E Wheelbase	134 in. (3400 mm)	134 in. (3400 mm)
F Dump Height	▲ (see page 22)	▲ (see page 23)
G Height to Hinge Pin, Fully Raised	14 ft. 1 in. (4281 mm)	15 ft. 11 in. (4848 mm)
H Dump Reach	▲▲ (see page 22)	▲▲ (see page 23)
I Maximum Digging Depth	3.6 in. (92 mm)	8.2 in. (208 mm)
J Overall Length	▲▲▲ (see page 22)	▲▲▲ (see page 23)
K Maximum Rollback at Ground Level	40 degrees	42 degrees

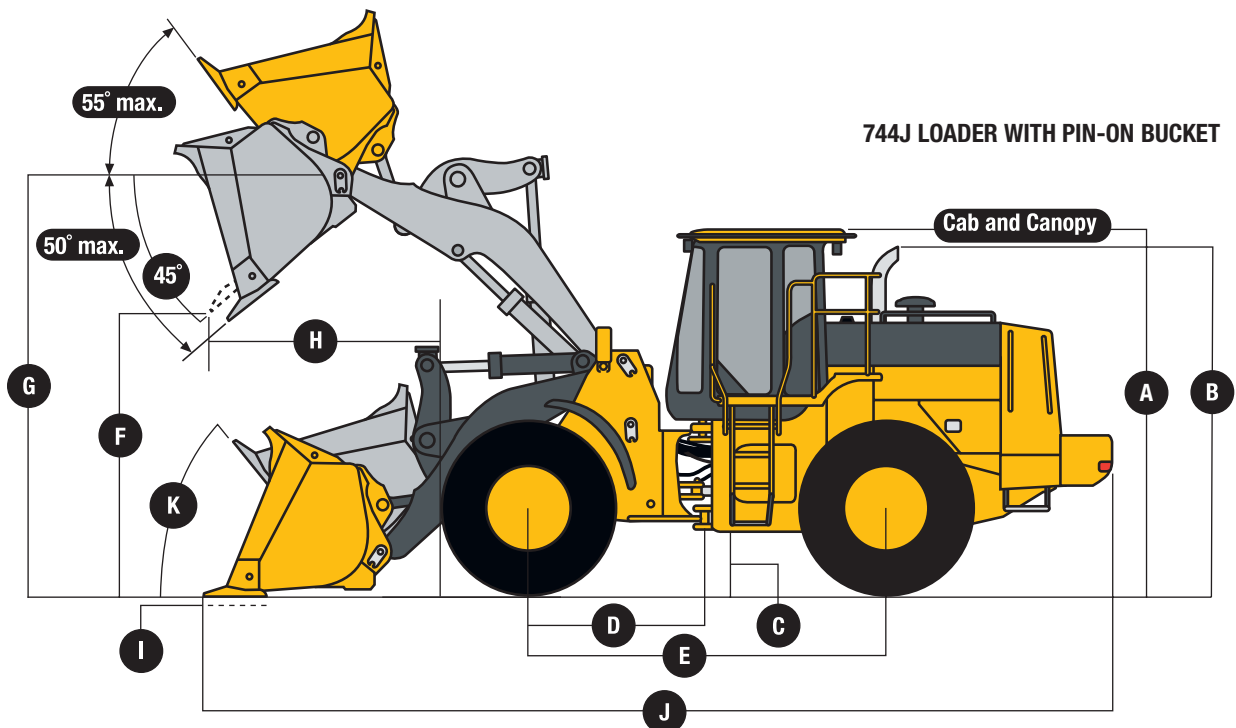

Dimensions with Quick-Coupler and Bucket

744J

- A** Dump Clearance ▲ (see page 23)
- B** Dump Reach ▲▲ (see page 23)
- C** Maximum Digging Depth 3.6 in. (93 mm)
- D** Height to Hinge Pin, Fully Raised 14 ft. 1 in. (4280 mm)
- E** Overall Length ▲▲▲ (see page 23)
- F** Maximum Rollback, Boom Fully Raised 55 degrees
- G** Maximum Bucket Discharge Angle, Fully Raised 50 degrees
- H** Maximum Rollback at Ground Level 40 degrees

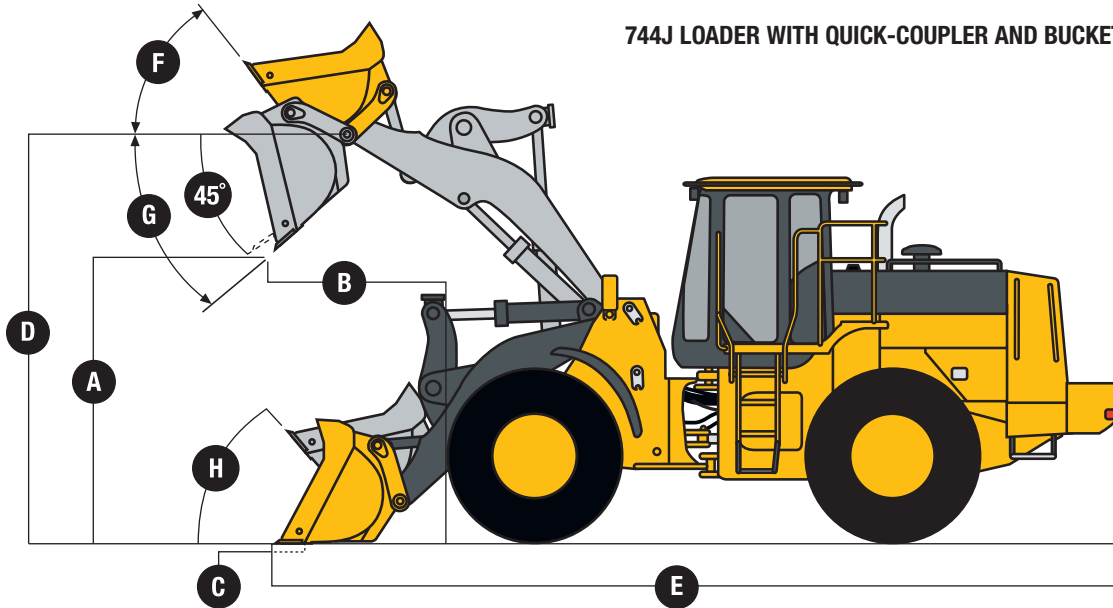

744J LOADER WITH QUICK-COUPLER AND BUCKET

Standard Z-Bar Information with Pin-On Type Bucket

744J

Bucket Type/Size	General Purpose w/Bolt-on Edge	General Purpose w/Teeth & Segments	General Purpose w/Jagz™	Light Material w/Bolt-on Edge	General Purpose w/Teeth & Segments
Capacity, Heaped SAE	5.25 cu. yd. (4.0 m³)	5.25 cu. yd. (4.0 m³)	5.25 cu. yd. (4.0 m³)	5.75 cu. yd. (4.4 m³)	4.5 cu. yd. (3.4 m³)
Capacity, Struck SAE	4.5 cu. yd. (3.4 m³)	4.5 cu. yd. (3.4 m³)	4.5 cu. yd. (3.4 m³)	5.0 cu. yd. (3.8 m³)	3.7 cu. yd. (2.8 m³)
Bucket Weight	5,027 lb. (2280 kg)	5,307 lb. (2407 kg)	5,089 lb. (2308 kg)	5,411 lb. (2454 kg)	5,023 lb. (2278 kg)
Bucket Width	119.7 in. (3040 mm)	119.7 in. (3040 mm)	119.7 in. (3040 mm)	128.9 in. (3275 mm)	119.7 in. (3040 mm)
Breakout Force, SAE J732C	44,526 lb. (20 193 kg)	44,526 lb. (20 193 kg)	42,164 lb. (19 122 kg)	38,834 lb. (17 612 kg)	47,145 lb. (21 380 kg)
Tipping Load, Straight	38,978 lb. (17 677 kg)	38,455 lb. (17 440 kg)	38,598 lb. (17 505 kg)	37,655 lb. (17 077 kg)	39,196 lb. (17 776 kg)
Tipping Load, 35-Degree Full Turn, SAE	33,928 lb. (15 387 kg)	33,560 lb. (15 220 kg)	34,067 lb. (15 450 kg)	32,691 lb. (14 826 kg)	34,230 lb. (15 524 kg)
Tipping Load, 40-Degree Full Turn, SAE	32,839 lb. (14 893 kg)	32,347 lb. (14 670 kg)	32,508 lb. (14 743 kg)	31,659 lb. (14 358 kg)	33,020 lb. (14 975 kg)
Reach, 45-Degree Dump, 7-ft. (2.13 m) Clearance	73.0 in. (1853 mm)	77.7 in. (1973 mm)	74.5 in. (1892 mm)	70.4 in. (1788 mm)	75.6 in. (1920 mm)
▲▲ Reach, 45-Degree Dump, Full Height	47.6 in. (1210 mm)	55.2 in. (1402 mm)	49.9 in. (1268 mm)	49.2 in. (1249 mm)	50.9 in. (1293 mm)
▲ Dump Clearance, 45 Degree, Full Height	121.7 in. (3090 mm)	115.3 in. (2929 mm)	119.9 in. (3045 mm)	114.2 in. (2900 mm)	120.1 in. (3050 mm)
▲▲▲ Overall Length, Bucket on Ground	27 ft. 11 in. (8504 mm)	28 ft. 9 in. (8754 mm)	28 ft. 2 in. (8574 mm)	28 ft. 6 in. (8682 mm)	28 ft. 2 in. (8574 mm)
Loader Clearance Circle, Bucket In Carry Position	44 ft. 8 in. (13 604 mm)	45 ft. 2 in. (13 754 mm)	44 ft. 9 in. (13 645 mm)	45 ft. 8 in. (13 914 mm)	44 ft. 9 in. (13 640 mm)
Operating Weight	51,467 lb. (23 341 kg)	51,749 lb. (23 469 kg)	51,529 lb. (23 369 kg)	51,851 lb. (23 515 kg)	51,211 lb. (23 225 kg)

Loader operating information is based on machine with all standard equipment; 26.5 R 25, 1-Star L3 Radial tires; ROPS/FOPS cab; 175-lb. (79 kg) operator; and full fuel tank. This information is affected by tire size, ballast, and different attachments.

Adjustments to Operating Weights for Standard Z-Bar with Pin-On Type Buckets

744J

Adjustments to operating weights and tipping loads based on standard boom and 5.25-cu.-yd. (4.0 m³) general-purpose bucket with bolt-on cutting edge

Add (+) or deduct (-) lb. (kg) as indicated for loaders with	Operating Weight	Tipping Load, Straight	Tipping Load, 35-Degree Full Turn	Tipping Load, 40-Degree Full Turn
26.5-25, 20 PR L3	- 699 lb. (- 317 kg)	- 475 lb. (- 215 kg)	- 426 lb. (- 193 kg)	- 412 lb. (- 187 kg)
26.5-25, 20 PR L5*	+ 3,554 lb. (+ 1612 kg)	+ 2,417 lb. (+ 1096 kg)	+ 2,168 lb. (+ 983 kg)	+ 2,097 lb. (+ 951 kg)
26.5 R 25, 1-Star L3 Radial	0 lb. (0 kg)	0 lb. (0 kg)	0 lb. (0 kg)	0 lb. (0 kg)
29.5 R 25, 1-Star L3 Radial	+ 2,608 lb. (+ 1183 kg)	+ 1,774 lb. (+ 804 kg)	+ 1,591 lb. (+ 722 kg)	+ 1,539 lb. (+ 698 kg)

*Requires 8-degree rear axle stops, close-mounted steps, and no fenders.

Standard Z-Bar Information with Quick-Coupler and Bucket

Bucket Type/Size	General Purpose w/Bolt-on Edge	General Purpose w/Bolt-on Edge
Capacity, Heaped SAE	5.5 cu. yd. (4.2 m ³)	5.25 cu. yd. (4.0 m ³)
Capacity, Struck SAE	5.0 cu. yd. (3.8 m ³)	4.75 cu. yd. (3.6 m ³)
Bucket Weight with Coupler	6,798 lb. (3083 kg)	6,681 lb. (3030 kg)
Bucket Width	120 in. (3048 mm)	120 in. (3048 mm)
Breakout Force, SAE J732C	35,002 lb. (15 877 kg)	36,235 lb. (16 433 kg)
Tipping Load, Straight	36,797 lb. (16 688 kg)	37,073 lb. (16 813 kg)
Tipping Load, 40-Degree Full Turn, SAE	30,800 lb. (13 968 kg)	31,049 lb. (14 081 kg)
Reach, 45-Degree Dump, 7-ft. (2.13 m) Clearance	78.3 in. (1988 mm)	77.4 in. (1966 mm)
▲▲ Reach, 45-Degree Dump, Full Height	57.0 in. (1447 mm)	55.5 in. (1409 mm)
▲ Dump Clearance, 45 Degree, Full Height	113.1 in. (2872 mm)	114.3 in. (2904 mm)
▲▲▲ Overall Length, Bucket on Ground	29 ft. 0 in. (8829 mm)	28 ft. 10 in. (8779 mm)
Loader Clearance Circle, Bucket In Carry Position	45 ft. 4 in. (13 806 mm)	45 ft. 2 in. (13 775 mm)
Operating Weight	53,116 lb. (24 089 kg)	53,000 lb. (24 036 kg)

Loader operating information is based on machine with all standard equipment; 26.5 R 25, 1-Star L3 Radial tires; ROPS/FOPS cab; 175-lb. (79 kg) operator; and full fuel tank. This information is affected by tire size, ballast, and different attachments.

High-Lift Z-Bar Information with Pin-On Type Bucket

Bucket Type/Size	General Purpose w/Bolt-on Edge
Capacity, Heaped SAE	4.5 cu. yd. (3.4 m ³)
Capacity, Struck SAE	3.7 cu. yd. (2.8 m ³)
Bucket Weight	4,721 lb. (2141 kg)
Bucket Width	119.7 in. (3040 mm)
Breakout Force, SAE J732C	42,332 lb. (19 198 kg)
Tipping Load, Straight	31,179 lb. (14 140 kg)
Tipping Load, 35-Degree Full Turn, SAE	27,122 lb. (12 300 kg)
Tipping Load, 40-Degree Full Turn, SAE	26,127 lb. (11 849 kg)
Reach, 45-Degree Dump, 7-ft. (2.13 m) Clearance	94.0 in. (2387 mm)
▲▲ Reach, 45-Degree Dump, Full Height	52.0 in. (1321 mm)*
▲ Dump Clearance, 45 Degree, Full Height	146 in. (3708 mm)*
▲▲▲ Overall Length, Bucket on Ground	29 ft. 9 in. (9072 mm)
Loader Clearance Circle, Bucket In Carry Position	46 ft. 5 in. (14 139 mm)
Operating Weight	51,985 lb. (23 576 kg)

*Dump clearance height and reach for this bucket determined with a 40-degree bucket dump angle.

Loader operating information is based on machine with all standard equipment; 26.5 R 25, 1-Star L3 Radial tires; ROPS/FOPS cab; 175-lb. (79 kg) operator; and full fuel tank. This information is affected by tire size, ballast, and different attachments.

744J Z-Bar Pin-On Bucket Selection Guide

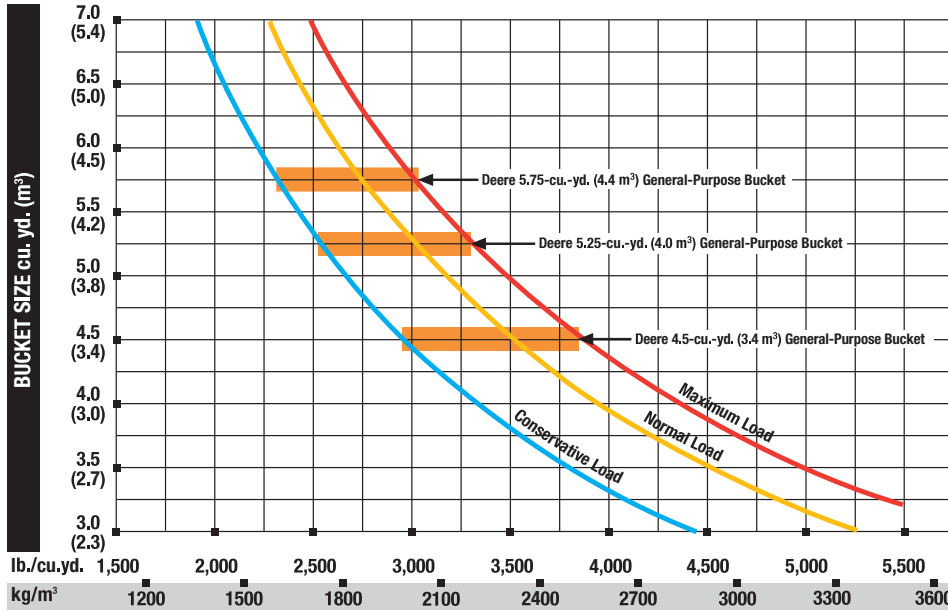

* This guide, representing bucket sizes not necessarily manufactured by Deere, will help you in selecting proper bucket size for material density, loader configuration, and operating conditions. Optimum bucket size is determined after adding or subtracting all tipping load changes due to optional equipment. The "conservative load" line on this guide is recommended when operating in conditions such as soft ground and unlevel surfaces. The "maximum load" condition on this guide is sometimes utilized when operating on firm ground and level surfaces.

MATERIAL (Loose weight)	lb./cu. yd.	kg/m³
Caliche	2,100	1250
Cinders	1,000	590
Clay and gravel, dry	2,400	1420
Clay and gravel, wet	2,600	1540
Clay, dry	2,500	1480
Clay, natural bed	2,800	1660
Clay, wet	2,800	1660
Coal, anthracite, broken	1,850	1100
Coal, bituminous, broken	1,400	830
Earth, dry, packed	2,550	1510
Earth, loam	2,100	1250
Earth, wet, excavated	2,700	1600
Granite, broken or large crushed	2,800	1660
Gravel, dry	2,550	1510
Gravel, dry 1/2" to 2" (13 to 50 mm)	2,850	1690
Gravel, pit run (graveled sand)	3,250	1930
Gravel, wet 1/2" to 2" (13 to 50 mm)	3,400	2020
Gypsum, crushed	2,700	1600
Limestone, broken or crushed	2,600	1540
Magnetite, iron ore	4,700	2790
Phosphate rock	2,160	1280
Pyrite, iron ore	4,350	2580
Sand and gravel, dry	2,900	1720
Sand and gravel, wet	3,400	2020
Sand, dry	2,400	1420
Sand, wet	3,100	1840
Sandstone, broken	2,550	1510
Shale	2,100	1250
Slag, broken	2,950	1750
Stone, crushed	2,700	1600
Topsoil	1,600	950

744J Z-Bar Quick-Coupler Bucket Selection Guide

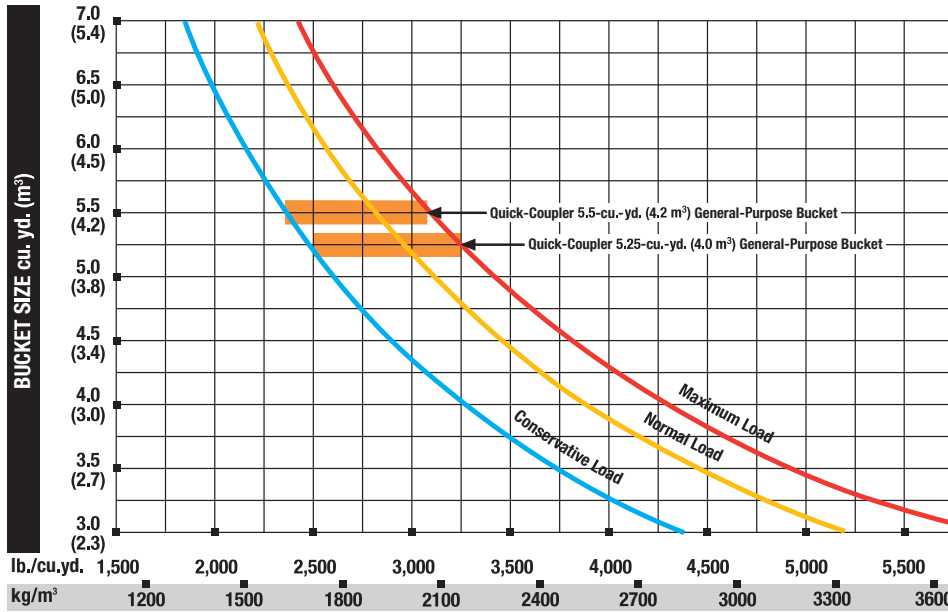

* This guide, representing bucket sizes not necessarily manufactured by Deere, will help you in selecting proper bucket size for material density, loader configuration, and operating conditions. Optimum bucket size is determined after adding or subtracting all tipping load changes due to optional equipment. The "conservative load" line on this guide is recommended when operating in conditions such as soft ground and unlevel surfaces. The "maximum load" condition on this guide is sometimes utilized when operating on firm ground and level surfaces.

MATERIAL (Loose weight)	lb./cu. yd.	kg/m³
Caliche	2,100	1250
Cinders	1,000	590
Clay and gravel, dry	2,400	1420
Clay and gravel, wet	2,600	1540
Clay, dry	2,500	1480
Clay, natural bed	2,800	1660
Clay, wet	2,800	1660
Coal, anthracite, broken	1,850	1100
Coal, bituminous, broken	1,400	830
Earth, dry, packed	2,550	1510
Earth, loam	2,100	1250
Earth, wet, excavated	2,700	1600
Granite, broken or large crushed	2,800	1660
Gravel, dry	2,550	1510
Gravel, dry 1/2" to 2" (13 to 50 mm)	2,850	1690
Gravel, pit run (graveled sand)	3,250	1930
Gravel, wet 1/2" to 2" (13 to 50 mm)	3,400	2020
Gypsum, crushed	2,700	1600
Limestone, broken or crushed	2,600	1540
Magnetite, iron ore	4,700	2790
Phosphate rock	2,160	1280
Pyrite, iron ore	4,350	2580
Sand and gravel, dry	2,900	1720
Sand and gravel, wet	3,400	2020
Sand, dry	2,400	1420
Sand, wet	3,100	1840
Sandstone, broken	2,550	1510
Shale	2,100	1250
Slag, broken	2,950	1750
Stone, crushed	2,700	1600
Topsoil	1,600	950

744J High-Lift Z-Bar Pin-On Bucket Selection Guide

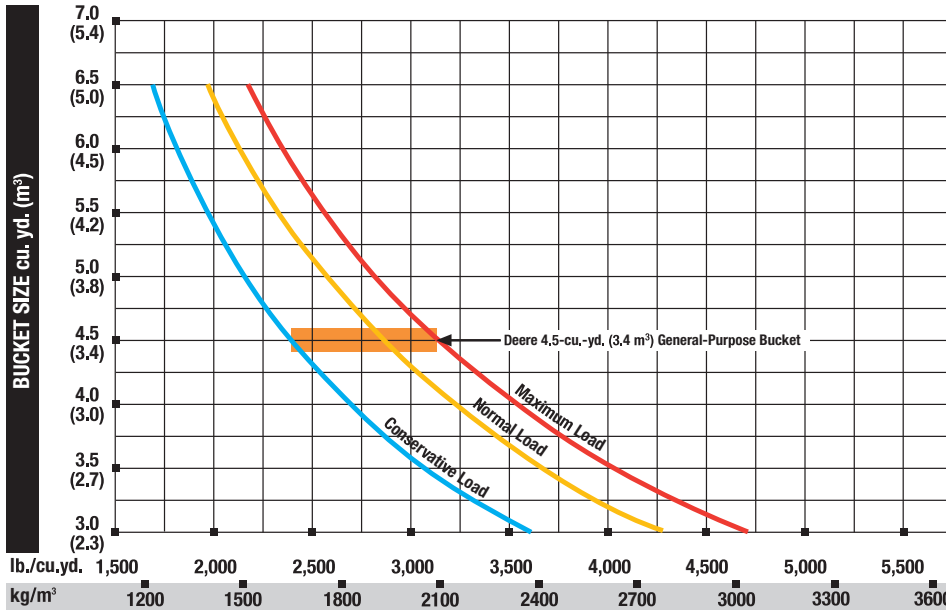

MATERIAL (Loose weight)	lb./cu. yd.	kg/m³
Caliche	2,100	1250
Cinders	1,000	590
Clay and gravel, dry	2,400	1420
Clay and gravel, wet	2,600	1540
Clay, dry	2,500	1480
Clay, natural bed	2,800	1660
Clay, wet	2,800	1660
Coal, anthracite, broken	1,850	1100
Coal, bituminous, broken	1,400	830
Earth, dry, packed	2,550	1510
Earth, loam	2,100	1250
Earth, wet, excavated	2,700	1600
Granite, broken or large crushed	2,800	1660
Gravel, dry	2,550	1510
Gravel, dry 1/2" to 2" (13 to 50 mm)	2,850	1690
Gravel, pit run (graveled sand)	3,250	1930
Gravel, wet 1/2" to 2" (13 to 50 mm)	3,400	2020
Gypsum, crushed	2,700	1600
Limestone, broken or crushed	2,600	1540
Magnetite, iron ore	4,700	2790
Phosphate rock	2,160	1280
Pyrite, iron ore	4,350	2580
Sand and gravel, dry	2,900	1720
Sand and gravel, wet	3,400	2020
Sand, dry	2,400	1420
Sand, wet	3,100	1840
Sandstone, broken	2,550	1510
Shale	2,100	1250
Slag, broken	2,950	1750
Stone, crushed	2,700	1600
Topsoil	1,600	950

* This guide, representing bucket sizes not necessarily manufactured by Deere, will help you in selecting proper bucket size for material density, loader configuration, and operating conditions. Optimum bucket size is determined after adding or subtracting all tipping load changes due to optional equipment. The "conservative load" line on this guide is recommended when operating in conditions such as soft ground and unlevel surfaces. The "maximum load" condition on this guide is sometimes utilized when operating on firm ground and level surfaces.

Specifications

Engine 824J

Type	John Deere POWERTECH™ 6125H; meets EPA Tier II non-road emissions regulations
Cylinders	6
Valves Per Cylinder	4
Displacement	766 cu. in. (12.5 L)
Net Peak Power	316 hp (236 kW) @ 1,500 rpm
Net Rated Power	275 hp (205 kW) @ 2,000 rpm
Net Peak Torque	1,115 lb.-ft. (1510 Nm) @ 1,200 rpm
Net Torque Rise	54%
Net Power Bulge	15%
Fuel System	mechanically actuated electronic unit injectors
Lube System	full-flow spin-on filter and integral cooler
Aspiration	turbocharged, charge air cooled
Air Cleaner	dual element dry type; restriction indicator in cab monitor for service
Fan Drive	belt driven, fan forward of coolers
Electrical System	24 volt with 80-amp alternator
Batteries (two 12 volt)	1,400 CCA; reserve capacity: 200 min.

Transmission

Type	countershaft-type power shift	
Torque Converter	single stage, dual phase with freewheeling stator	
Shift Control	electronically modulated, adaptive, load and speed dependent	
Operator Interface	steering column-mounted twist-grip shift lever, quick-shift button on hydraulic lever	
Shift Modes	auto/manual, auto to 1st or 2nd, kick down or kick up/down, three clutch cutoff settings	
Travel Speeds*	<i>Forward</i>	<i>Reverse</i>
Gear 1	4.6 mph (7.4 km/h)	4.6 mph (7.4 km/h)
Gear 2	8.6 mph (13.9 km/h)	8.6 mph (13.9 km/h)
Gear 3	13.1 mph (21.2 km/h)	19.3 mph (31.0 km/h)
Gear 4	24.5 mph (39.5 km/h)	

*Equipped with 26.5 R 25 tires.

Axles/Brakes

Final Drives	heavy-duty inboard planetary
Differentials*	hydraulic locking front, conventional rear — standard; dual locking front and rear — optional
Rear Axle Oscillation, Stop to Stop**	26 degrees
Brakes (conform to SAE J1473, ISO3450)	
Service Brakes	hydraulically actuated, inboard, sun gear mounted, pressure oil cooled, self adjusting, single disc
Parking Brake	automatically spring applied, hydraulically released, oil cooled, multi disc

*Contact dealer for information regarding limited slip and conventional front and rear availability.

**Equipped with 26.5 R 25 tires.

Tires

Choice of (with five-piece rims)	Tread Width	Width Over Tires	Change In Vertical Height
26.5-25, 20 PR L3	90.6 in. (2300 mm)	120.0 in. (3048 mm)	+ 0.7 in. (+ 18 mm)
26.5-25, 20 PR L5*	90.6 in. (2300 mm)	119.7 in. (3040 mm)	+ 3.9 in. (+ 98 mm)
26.5 R 25, 1-Star L3 Radial	90.6 in. (2300 mm)	119.6 in. (3038 mm)	0 in. (0 mm)
29.5 R 25, 1-Star L3 Radial*	90.6 in. (2300 mm)	122.6 in. (3114 mm)	+ 2.2 in. (+ 57 mm)

*Requires 8-degree rear axle stops, close-mounted steps, and no fenders.

Refill Capacities (U.S.)

Fuel Tank (with ground-level fueling)	122 gal. (462 L)
Cooling System	40 qt. (38 L)
Engine Lubrication, Including Vertical Spin-	
On Filter	40 qt. (38 L)
Powershift Transmission, Including Filter	30 qt. (28 L)
Differential (front and rear, each axle)	49 qt. (46 L)
Loader Hydraulic Reservoir and Filters	38 gal. (144 L)
Sealed Wet-Disc Parking Brake	20 oz. (600 mL)

Hydraulic System/Steering

824J

Pump (loader and steering)	two variable-displacement, load-sensing axial piston pumps; closed-center system	
Maximum Flow @ 2,250 rpm	112 gpm (423 L/min.) @ 1,000 psi (6900 kPa)	
Pressure	loader and steering relief 3,600 psi (24 850 kPa)	
Loader Controls	two-function valve; single- and dual-lever controls; control lever lockout feature; optional third- and fourth-function valve with auxiliary lever	
Steering (conforms to SAE J1511)		
Type	power, fully hydraulic	
Pressure	3,600 psi (24 850 kPa) relief	
Articulation Angle	80-degree arc (40 degrees each direction)	
Hydraulic Cycle Times	<i>Standard Z-Bar</i>	<i>High-Lift Z-Bar</i>
Raise	6.1 sec.	6.6 sec.
Dump	1.5 sec.	1.5 sec.
Lower	2.8 sec. (float down)	3.0 sec. (float down)
Total	10.4 sec.	11.1 sec.
	<i>with 6.0-cu.-yd. (4.6 m³) general-purpose bucket with bolt-on cutting edge</i>	<i>with 5.75-cu.-yd. (4.4 m³) general-purpose bucket with bolt-on cutting edge</i>
Maximum Lift Capacity		
Lift at Ground Level	44,634 lb. (20 242 kg)	43,196 lb. (19 590 kg)
Lift at Maximum Height	26,266 lb. (11 912 kg)	26,105 lb. (11 839 kg)
Turning Radius (measured to centerline of outside tire)	20 ft. 2 in. (6140 mm)	20 ft. 2 in. (6140 mm)

Dimensions with Pin-On Bucket

	<i>Standard Z-Bar</i>	<i>High-Lift Z-Bar</i>
A Height to Top of Cab and Canopy	11 ft. 7 in. (3520 mm)	11 ft. 7 in. (3520 mm)
B Height to Top of Exhaust	10 ft. 2 in. (3100 mm)	10 ft. 2 in. (3100 mm)
C Ground Clearance	18.3 in. (465 mm)	18.3 in. (465 mm)
D Length from Centerline to Front Axle	67 in. (1700 mm)	67 in. (1700 mm)
E Wheelbase	134 in. (3400 mm)	134 in. (3400 mm)
F Dump Height	▲ (see page 28)	▲ (see page 29)
G Height to Hinge Pin, Fully Raised	14 ft. 10 in. (4508 mm)	15 ft. 11 in. (4848 mm)
H Dump Reach	▲▲ (see page 28)	▲▲ (see page 29)
I Maximum Digging Depth	3.2 in. (82 mm)	8.0 in. (202 mm)
J Overall Length	▲▲▲ (see page 28)	▲▲▲ (see page 29)
K Maximum Rollback at Ground Level	45 degrees	42 degrees

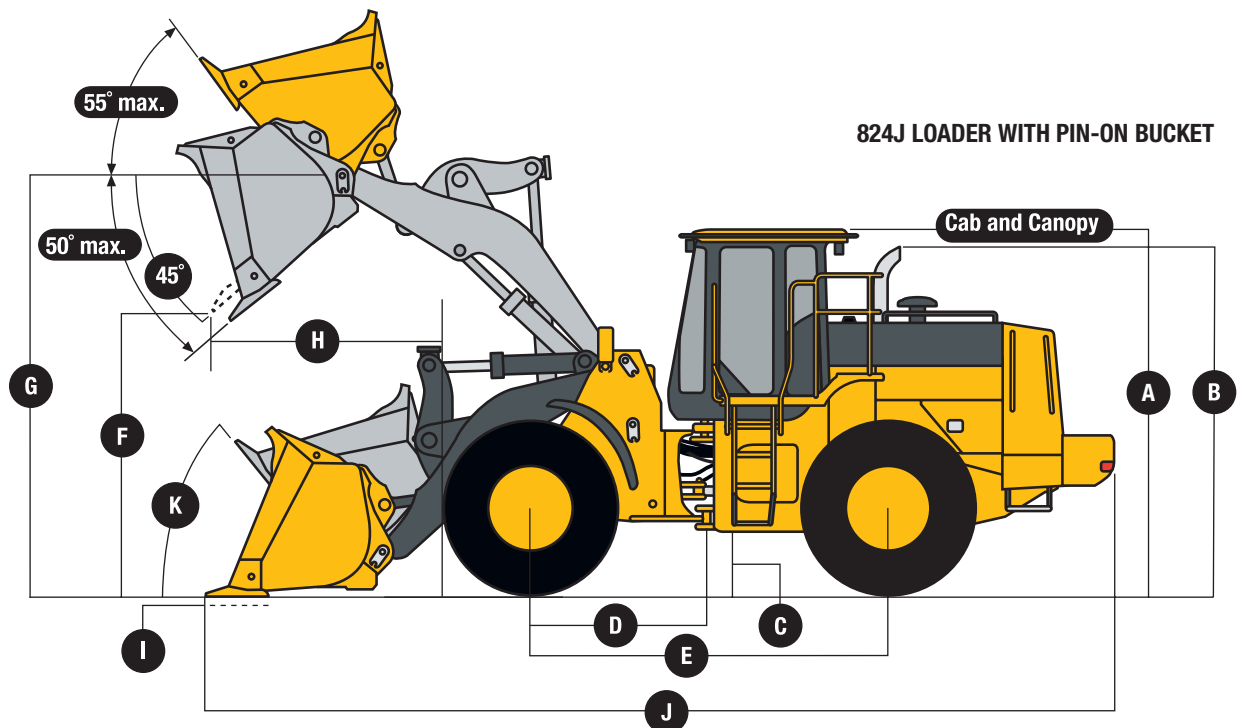

Dimensions with Quick-Coupler and Bucket

824J

- A** Dump Clearance▲ (see page 29)
- B** Dump Reach▲▲ (see page 29)
- C** Maximum Digging Depth3.7 in. (94 mm)
- D** Height to Hinge Pin, Fully Raised14 ft. 10 in. (4508 mm)
- E** Overall Length▲▲▲ (see page 29)
- F** Maximum Rollback, Boom Fully Raised52 degrees
- G** Maximum Bucket Discharge Angle, Fully Raised45 degrees
- H** Maximum Rollback at Ground Level45 degrees

824J LOADER WITH QUICK-COUPLER AND BUCKET

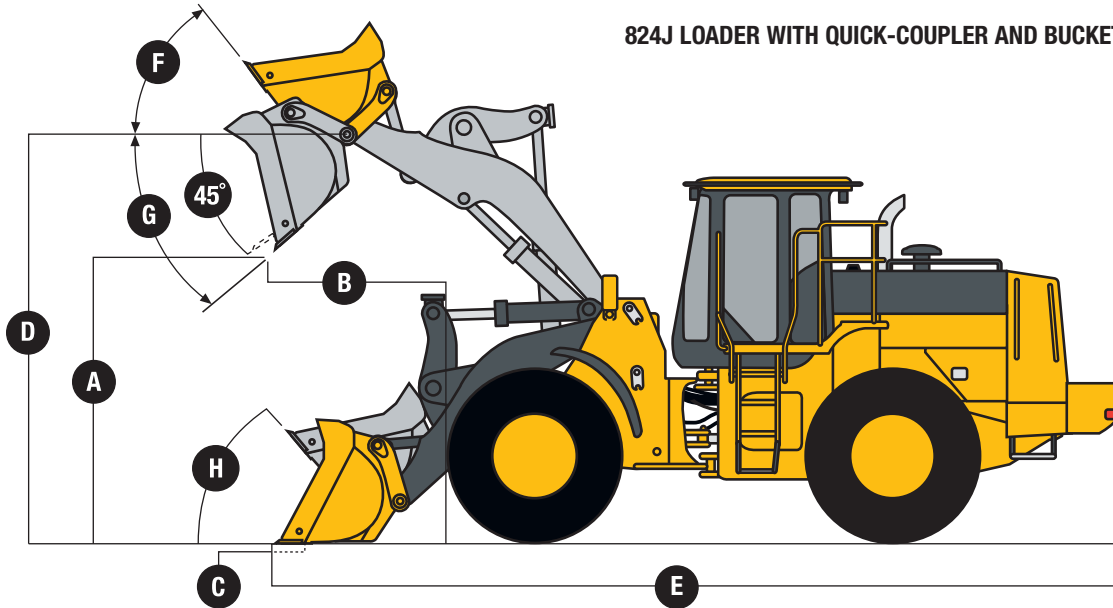

Standard Z-Bar Information with Pin-On Type Bucket

824J

	<i>General Purpose w/Bolt-on Edge</i>	<i>General Purpose w/Teeth & Segments</i>	<i>General Purpose w/Jagz™</i>	<i>General Purpose w/Bolt-on Edge</i>	<i>Light Material w/Bolt-on Edge</i>
Bucket Type/Size					
Capacity, Heaped SAE	6.0 cu. yd. (4.6 m³)	6.0 cu. yd. (4.6 m³)	6.0 cu. yd. (4.6 m³)	5.75 cu. yd. (4.4 m³)	6.75 cu. yd. (5.2 m³)
Capacity, Struck SAE	5.25 cu. yd. (4.0 m³)	5.25 cu. yd. (4.0 m³)	5.25 cu. yd. (4.0 m³)	4.9 cu. yd. (3.74 m³)	5.8 cu. yd. (4.5 m³)
Bucket Weight	5,768 lb. (2616 kg)	6,046 lb. (2742 kg)	5,808 lb. (2634 kg)	5,411 lb. (2454 kg)	5,991 lb. (2717 kg)
Bucket Width	128.9 in. (3275 mm)	128.9 in. (3275 mm)	128.9 in. (3275 mm)	128.9 in. (3275 mm)	128.9 in. (3275 mm)
Breakout Force, SAE J732C	42,916 lb. (19 463 kg)	42,916 lb. (19 463 kg)	42,916 lb. (19 463 kg)	42,146 lb. (19 114 kg)	40,129 lb. (18 199 kg)
Tipping Load, Straight	42,523 lb. (19 285 kg)	42,177 lb. (19 128 kg)	42,482 lb. (19 266 kg)	41,798 lb. (18 956 kg)	42,290 lb. (19 179 kg)
Tipping Load, 35-Degree Full Turn, SAE	37,046 lb. (16 801 kg)	36,707 lb. (16 647 kg)	37,004 lb. (16 782 kg)	36,438 lb. (16 525 kg)	36,817 lb. (16 697 kg)
Tipping Load, 40-Degree Full Turn, SAE	35,708 lb. (16 194 kg)	35,366 lb. (16 039 kg)	35,664 lb. (16 174 kg)	35,126 lb. (15 930 kg)	35,476 lb. (16 089 kg)
Reach, 45-Degree Dump, 7-ft. (2.13 m) Clearance	80.8 in. (2052 mm)	84.1 in. (2136 mm)	80.8 in. (2052 mm)	74.7 in. (1898 mm)	82.6 in. (2097 mm)
▲▲ Reach, 45-Degree Dump, Full Height	48.9 in. (1243 mm)*	54.3 in. (1379 mm)*	48.9 in. (1243 mm)*	49.6 in. (1259 mm)*	51.8 in. (1315 mm)*
▲ Dump Clearance, 45 Degree, Full Height	127.2 in. (3230 mm)*	122.6 in. (3115 mm)*	127.2 in. (3230 mm)*	126.0 in. (3201 mm)*	124.8 in. (3169 mm)*
▲▲▲ Overall Length, Bucket on Ground	29 ft. 3 in. (8906 mm)	29 ft. 10 in. (9084 mm)	29 ft. 3 in. (8906 mm)	29 ft. 6 in. (9001 mm)	29 ft. 6 in. (9000 mm)
Loader Clearance Circle, Bucket In Carry Position	45 ft. 9 in. (13 940 mm)	46 ft. 1 in. (14 038 mm)	45 ft. 9 in. (13 940 mm)	45 ft. 10 in. (13 964 mm)	45 ft. 11 in. (13 991 mm)
Operating Weight	57,374 lb. (26 020 kg)	57,652 lb. (26 146 kg)	57,413 lb. (26 038 kg)	56,993 lb. (25 847 kg)	57,595 lb. (26 120 kg)

*Dump clearance height and reach for this bucket determined with a 40-degree bucket dump angle.

Loader operating information is based on machine with all standard equipment; 26.5 R 25, 1-Star L3 Radial tires; ROPS/FOPS cab; 175-lb. (79 kg) operator; and full fuel tank. This information is affected by tire size, ballast, and different attachments.

Adjustments to Operating Weights for Standard Z-Bar with Pin-On Type Buckets

824J

Adjustments to operating weights and tipping loads based on standard boom and 6.0-cu.-yd. (4.6 m³) general-purpose bucket with bolt-on cutting edge

Add (+) or deduct (-) lb. (kg) as indicated for loaders with	Operating Weight	Tipping Load, Straight	Tipping Load, 35-Degree Full Turn	Tipping Load, 40-Degree Full Turn
26.5-25, 20 PR L3	- 699 lb. (- 317 kg)	- 475 lb. (- 215 kg)	- 412 lb. (- 187 kg)	- 398 lb. (- 181 kg)
26.5-25, 20 PR L5*	+ 3,554 lb. (+ 1612 kg)	+ 2,417 lb. (+ 1096 kg)	+ 2,097 lb. (+ 951 kg)	+ 2,026 lb. (+ 919 kg)
26.5 R 25, 1-Star L3 Radial	0 lb. (0 kg)	0 lb. (0 kg)	0 lb. (0 kg)	0 lb. (0 kg)
29.5 R 25, 1-Star L3 Radial	+ 2,608 lb. (+ 1183 kg)	+ 1,774 lb. (+ 804 kg)	+ 1,539 lb. (+ 698 kg)	+ 1,487 lb. (+ 674 kg)

*Requires 8-degree rear axle stops, close-mounted steps, and no fenders.

Standard Z-Bar Information with Quick-Coupler and Bucket

Bucket Type/Size	General Purpose w/Bolt-on Edge	General Purpose w/Bolt-on Edge
Capacity, Heaped SAE	5.5 cu. yd. (4.2 m ³)	5.25 cu. yd. (4.0 m ³)
Capacity, Struck SAE	5.0 cu. yd. (3.8 m ³)	4.75 cu. yd. (3.6 m ³)
Bucket Weight with Coupler	6,798 lb. (3083 kg)	6,681 lb. (3030 kg)
Bucket Width	120 in. (3048 mm)	120 in. (3048 mm)
Breakout Force, SAE J732C	37,963 lb. (17 217 kg)	39,280 lb. (17 814 kg)
Tipping Load, Straight	41,161 lb. (18 667 kg)	41,445 lb. (18 796 kg)
Tipping Load, 40-Degree Full Turn, SAE	34,451 lb. (15 624 kg)	34,709 lb. (15 741 kg)
Reach, 45-Degree Dump, 7-ft. (2.13 m) Clearance	82.9 in. (2105 mm)*	82.0 in. (2083 mm)*
▲▲ Reach, 45-Degree Dump, Full Height	53.9 in. (1369 mm)*	52.4 in. (1330 mm)*
▲ Dump Clearance, 45 Degree, Full Height	122.4 in. (3109 mm)	123.7 in. (3141 mm)
▲▲▲ Overall Length, Bucket on Ground	29 ft. 10 in. (9089 mm)	29 ft. 8 in. (9039 mm)
Loader Clearance Circle, Bucket In Carry Position	45 ft. 5 in. (13 840 mm)	45 ft. 4 in. (13 812 mm)
Operating Weight	58,404 lb. (26 487 kg)	58,285 lb. (26 433 kg)

*Dump clearance height and reach for this bucket determined with a 40-degree bucket dump angle.

Loader operating information is based on machine with all standard equipment; 26.5 R 25, 1-Star L3 Radial tires; ROPS/FOPS cab; 175-lb. (79 kg) operator; and full fuel tank. This information is affected by tire size, ballast, and different attachments.

High-Lift Z-Bar Information with Pin-On Type Bucket

Bucket Type/Size	General Purpose w/Bolt-on Edge	General Purpose w/Bolt-on Edge
Capacity, Heaped SAE	5.25 cu. yd. (4.0 m ³)	5.75 cu. yd. (4.4 m ³)
Capacity, Struck SAE	4.5 cu. yd. (3.4 m ³)	4.9 cu. yd. (3.74 m ³)
Bucket Weight	5,027 lb. (2280 kg)	5,411 lb. (2454 kg)
Bucket Width	119.7 in. (3040 mm)	128.9 in. (3275 mm)
Breakout Force, SAE J732C	45,258 lb. (20 525 kg)	39,500 lb. (17 914 kg)
Tipping Load, Straight	36,354 lb. (16 487 kg)	35,260 lb. (15 991 kg)
Tipping Load, 35-Degree Full Turn, SAE	31,622 lb. (14 341 kg)	30,619 lb. (13 886 kg)
Tipping Load, 40-Degree Full Turn, SAE	30,460 lb. (13 814 kg)	29,479 lb. (13 369 kg)
Reach, 45-Degree Dump, 7-ft. (2.13 m) Clearance	94.9 in. (2410 mm)	93.0 in. (2362 mm)
▲▲ Reach, 45-Degree Dump, Full Height	53.7 in. (1363 mm)*	59.8 in. (1518 mm)*
▲ Dump Clearance, 45 Degree, Full Height	144.0 in. (3658 mm)*	140.0 in. (3555 mm)*
▲▲▲ Overall Length, Bucket on Ground	30 ft. 5 in. (9271 mm)	31 ft. 0 in. (9450 mm)
Loader Clearance Circle, Bucket In Carry Position	46 ft. 5 in. (14 152 mm)	47 ft. 6 in. (14 469 mm)
Operating Weight	57,304 lb. (25 988 kg)	57,687 lb. (26 162 kg)

*Dump clearance height and reach for this bucket determined with a 40-degree bucket dump angle.

Loader operating information is based on machine with all standard equipment; 26.5 R 25, 1-Star L3 Radial tires; ROPS/FOPS cab; 175-lb. (79 kg) operator; and full fuel tank. This information is affected by tire size, ballast, and different attachments.

824J Z-Bar Pin-On Bucket Selection Guide

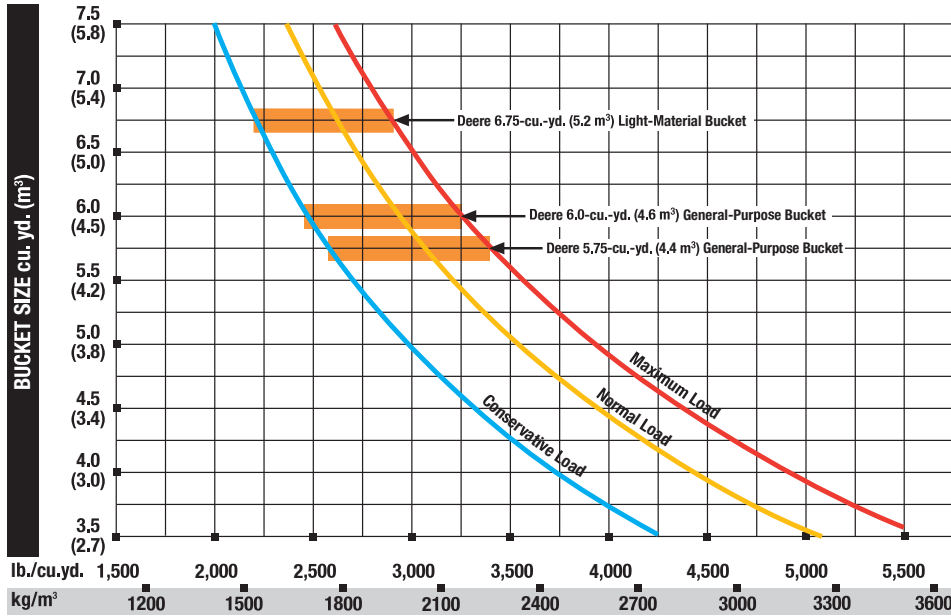

* This guide, representing bucket sizes not necessarily manufactured by Deere, will help you in selecting proper bucket size for material density, loader configuration, and operating conditions. Optimum bucket size is determined after adding or subtracting all tipping load changes due to optional equipment. The "conservative load" line on this guide is recommended when operating in conditions such as soft ground and unlevel surfaces. The "maximum load" condition on this guide is sometimes utilized when operating on firm ground and level surfaces.

MATERIAL (Loose weight)	lb./cu. yd.	kg/m³
Caliche	2,100	1250
Cinders	1,000	590
Clay and gravel, dry	2,400	1420
Clay and gravel, wet	2,600	1540
Clay, dry	2,500	1480
Clay, natural bed	2,800	1660
Clay, wet	2,800	1660
Coal, anthracite, broken	1,850	1100
Coal, bituminous, broken	1,400	830
Earth, dry, packed	2,550	1510
Earth, loam	2,100	1250
Earth, wet, excavated	2,700	1600
Granite, broken or large crushed	2,800	1660
Gravel, dry	2,550	1510
Gravel, dry 1/2" to 2" (13 to 50 mm)	2,850	1690
Gravel, pit run (graveled sand)	3,250	1930
Gravel, wet 1/2" to 2" (13 to 50 mm)	3,400	2020
Gypsum, crushed	2,700	1600
Limestone, broken or crushed	2,600	1540
Magnetite, iron ore	4,700	2790
Phosphate rock	2,160	1280
Pyrite, iron ore	4,350	2580
Sand and gravel, dry	2,900	1720
Sand and gravel, wet	3,400	2020
Sand, dry	2,400	1420
Sand, wet	3,100	1840
Sandstone, broken	2,550	1510
Shale	2,100	1250
Slag, broken	2,950	1750
Stone, crushed	2,700	1600
Topsoil	1,600	950

824J Z-Bar Quick-Coupler Bucket Selection Guide

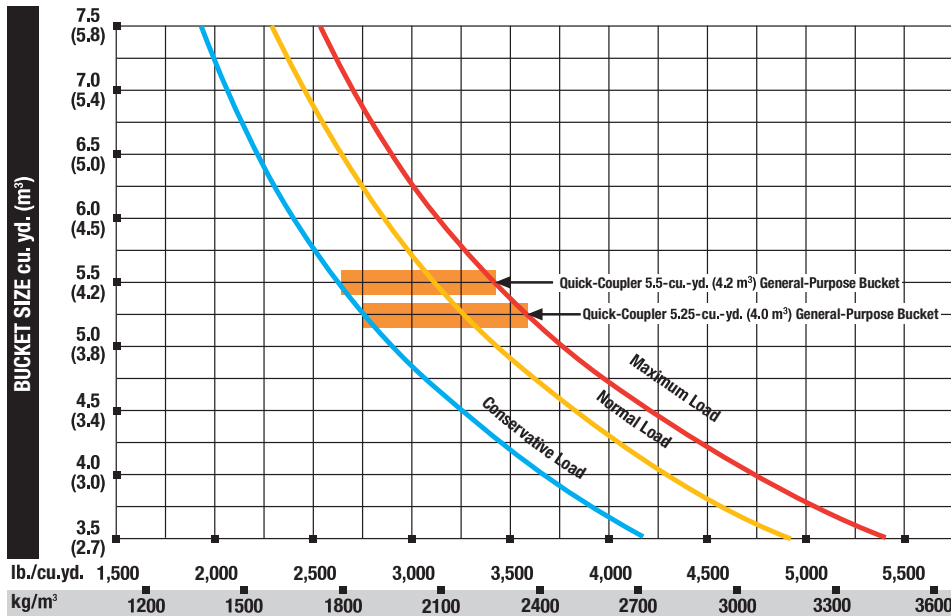

* This guide, representing bucket sizes not necessarily manufactured by Deere, will help you in selecting proper bucket size for material density, loader configuration, and operating conditions. Optimum bucket size is determined after adding or subtracting all tipping load changes due to optional equipment. The "conservative load" line on this guide is recommended when operating in conditions such as soft ground and unlevel surfaces. The "maximum load" condition on this guide is sometimes utilized when operating on firm ground and level surfaces.

MATERIAL (Loose weight)	lb./cu. yd.	kg/m³
Caliche	2,100	1250
Cinders	1,000	590
Clay and gravel, dry	2,400	1420
Clay and gravel, wet	2,600	1540
Clay, dry	2,500	1480
Clay, natural bed	2,800	1660
Clay, wet	2,800	1660
Coal, anthracite, broken	1,850	1100
Coal, bituminous, broken	1,400	830
Earth, dry, packed	2,550	1510
Earth, loam	2,100	1250
Earth, wet, excavated	2,700	1600
Granite, broken or large crushed	2,800	1660
Gravel, dry	2,550	1510
Gravel, dry 1/2" to 2" (13 to 50 mm)	2,850	1690
Gravel, pit run (graveled sand)	3,250	1930
Gravel, wet 1/2" to 2" (13 to 50 mm)	3,400	2020
Gypsum, crushed	2,700	1600
Limestone, broken or crushed	2,600	1540
Magnetite, iron ore	4,700	2790
Phosphate rock	2,160	1280
Pyrite, iron ore	4,350	2580
Sand and gravel, dry	2,900	1720
Sand and gravel, wet	3,400	2020
Sand, dry	2,400	1420
Sand, wet	3,100	1840
Sandstone, broken	2,550	1510
Shale	2,100	1250
Slag, broken	2,950	1750
Stone, crushed	2,700	1600
Topsoil	1,600	950

824J High Lift Z-Bar Pin-On Bucket Selection Guide

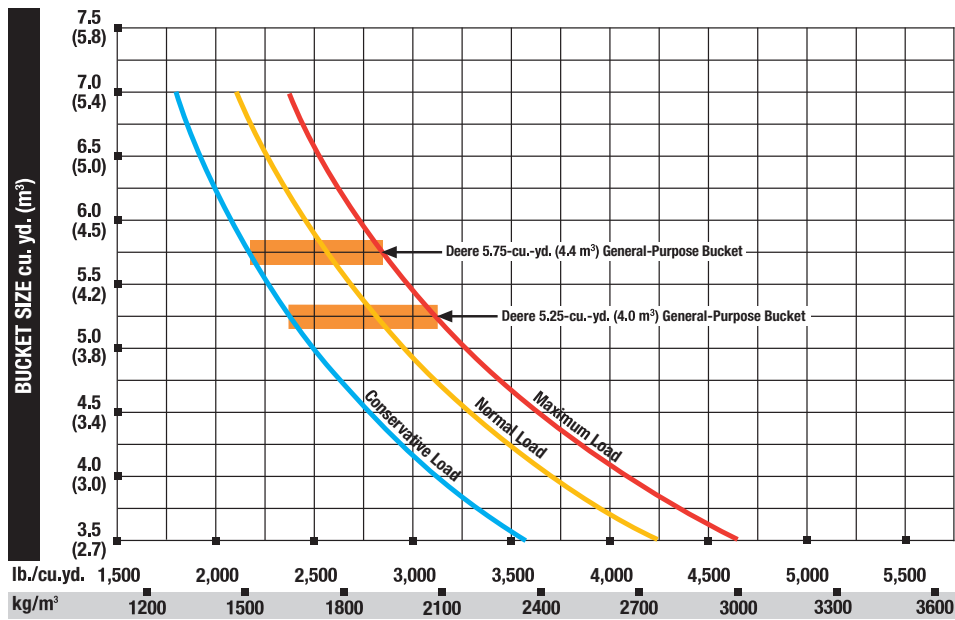

MATERIAL (Loose weight)	lb./cu. yd.	kg/m ³
Caliche	2,100	1250
Cinders	1,000	590
Clay and gravel, dry	2,400	1420
Clay and gravel, wet	2,600	1540
Clay, dry	2,500	1480
Clay, natural bed	2,800	1660
Clay, wet	2,800	1660
Coal, anthracite, broken	1,850	1100
Coal, bituminous, broken	1,400	830
Earth, dry, packed	2,550	1510
Earth, loam	2,100	1250
Earth, wet, excavated	2,700	1600
Granite, broken or large crushed	2,800	1660
Gravel, dry	2,550	1510
Gravel, dry 1/2" to 2" (13 to 50 mm)	2,850	1690
Gravel, pit run (graveled sand)	3,250	1930
Gravel, wet 1/2" to 2" (13 to 50 mm)	3,400	2020
Gypsum, crushed	2,700	1600
Limestone, broken or crushed	2,600	1540
Magnetite, iron ore	4,700	2790
Phosphate rock	2,160	1280
Pyrite, iron ore	4,350	2580
Sand and gravel, dry	2,900	1720
Sand and gravel, wet	3,400	2020
Sand, dry	2,400	1420
Sand, wet	3,100	1840
Sandstone, broken	2,550	1510
Shale	2,100	1250
Slag, broken	2,950	1750
Stone, crushed	2,700	1600
Topsoil	1,600	950

* This guide, representing bucket sizes not necessarily manufactured by Deere, will help you in selecting proper bucket size for material density, loader configuration, and operating conditions. Optimum bucket size is determined after adding or subtracting all tipping load changes due to optional equipment. The "conservative load" line on this guide is recommended when operating in conditions such as soft ground and uneven surfaces. The "maximum load" condition on this guide is sometimes utilized when operating on firm ground and level surfaces.

724J / 744J / 824J LOADERS

Key: ● Standard equipment ▲ Optional equipment

*See your John Deere dealer for further information.

724 744 824 Engine

- ● ● Meets EPA Tier II non-road emissions regulations
- ● ● Antifreeze, -34°F (-37°C)
- ● ● Coolant recovery tank
- ● ● Fan guard
- ● ● Muffler, under hood with large exhaust stack
- ● ● Environmentally friendly engine oil drain
- ● ● Engine oil cooler
- ● ● Quick-release fuel filter and water separator
- ▲ ▲ ▲ Ether start aid (for cold starts)
- ▲ ▲ ▲ Engine air heater (for cold starts)
- ▲ ▲ ▲ Engine coolant heater, 1,000 watts, 110 volts
- ▲ ▲ ▲ Heavy-duty trash-resistant cooling package
- ▲ ▲ ▲ Desert and high-altitude cooling package
- ▲ ▲ ▲ Special application trash screens, axle seal guards, etc.*
- ▲ ▲ ▲ Chrome exhaust stack

Power Train

- ● ● TC/PS transmission, computer-controlled electronic soft shift, automatic shift and quick-shift features included
- ● ● Front axle with hydraulic locking differential
- ▲ ▲ ▲ Conventional-type differentials, front and rear
- ▲ ▲ ▲ Front and rear axle with hydraulic locking differentials
- ▲ Limited slip differentials*
- ● ● Spin-control system
- ▲ Heavy-duty axle with 4-in.-wider wheelbase

Hydraulic System

- ● ● In-cab adjustable automatic bucket positioner
- ● ● In-cab adjustable automatic boom height kickout control
- ● ● In-cab adjustable automatic boom return-to-carry control
- ● ● Reservoir sight gauge
- ● ● Spin-on hydraulic filters, vertical mounting
- ● ● Hydraulic lever lockout
- ● ● Two-function hydraulic valve with two-lever fingertip control and adjustable wristrest
- ▲ ▲ ▲ Two-function hydraulic valve with joystick control
- ▲ ▲ ▲ Three-function hydraulic valve with joystick control and auxiliary lever for third function
- ▲ ▲ ▲ Three-function hydraulic valve with two-lever fingertip control, adjustable wristrest, and auxiliary lever for third function
- ▲ Four-function hydraulic valve, with dual joystick control
- ▲ ▲ ▲ Hydraulic conversion kits, two- to three-function valves
- ▲ Hydraulic conversion kits, three- to four-function valves

724 744 824 Hydraulic System (continued)

- ● ● Hydraulic system oil cooler (for continuous running attachments and extreme temperatures)
- ▲ ▲ ▲ Ride control, automatic type
- ▲ ▲ ▲ Hydraulic control system for quick-coupler locking pins

Electrical

- ● ● Solid-state electrical power distribution system
 - ● ● 24-volt electrical system
 - ● ● High-capacity batteries (2), 12 volt with 1,400 CCA, 200-min. rated reserve
 - ● ● Master electrical disconnect switch
 - ● ● Alternator, high capacity, 80 amps and 24 volts
 - ▲ ▲ ▲ Alternator trash covers
 - ● ● Lights (conform to SAE 99): Driving with guards / Turn signals and flashers / Stop and taillights
 - ● ● Work lights, front (2) and rear (2)
 - ● ● Horn, with push button in center of steering wheel (conforms to SAE J994, J1446)
 - ● ● Reverse warning alarm (conforms to SAE J994, J1446)
 - ● ● Computerized multifunction monitor
 - ● ● Audible and visual warnings: Amber caution / Red stop / Analog gauges: Engine coolant temperature, transmission oil temperature, fuel level, hydraulic oil temperature, engine oil pressure / Digital instruments: Engine rpm, odometer, transmission gear indicator, speedometer, hourmeter / Operator warning lights: Check engine, engine oil pressure, engine air filter restriction, battery voltage, transmission filter restriction, brake pressure, hydraulic oil filter, fasten seat belt, transmission fault, hydraulic oil temperature
 - ● ● Indicator lights: Park brake / Ride control / Turn signals and warning flashers / Coupler pin disconnect / Engine preheater / Secondary steering / Work lights
 - ● ● Radio-ready cab
 - ● ● 24-volt to 12-volt radio converter, 5 amp with receptacle
 - ▲ ▲ ▲ 24-volt to 12-volt radio converter, 10 amp with receptacle
 - ▲ ▲ ▲ 24-volt AM/FM stereo radio with cassette
 - ▲ ▲ ▲ 24-volt AM/FM stereo radio with CD
 - ▲ ▲ ▲ 24-volt AM/FM stereo radio with clock
 - ● ● Cab wired for rotating beacon
- ### Operator's Station
- ● ● Cab (conforms to SAE J1040 APR88): ROPS/FOPS / Heater/defroster / Multiplane isolation mounted for noise/vibration reduction / Front and rear windshield washers and intermittent wipers / Tinted safety glass
 - ● ● Air conditioning

724 744 824 Operator's Station (continued)

- ● ● Seat belt, 3 in. (76 mm), with retractor
- ● ● Seat, deluxe cloth covered with deep foam, high back, mechanical suspension, adjustable for weight-height, fore-aft position, backrest tilt, and armrest angle
- ● ● Cup holder, personal cooler holder, and storage space
- ▲ ▲ ▲ Sun visor for cab
- ● ● Rubber floor mat
- ● ● Tilt steering column
- ● ● Rearview mirrors, outside (2) and inside (2) (conform to SAE J985)
- ● ● Platforms, handrails, and steps, right and left, ergonomically located and slip resistant

Loader Linkage

- ● ● Loader boom service locking bar (conforms to SAE J38)
- ● ● Z-bar loader linkage provides "high bucket breakout"
- ▲ ▲ ▲ High-lift boom

Buckets and Attachments

- ▲ ▲ ▲ Full line of Deere pin-on buckets with selection of bolt-on cutting edges, JAGZ™ cutting edges, and teeth-segmented bolt-on cutting edges*

Tires

- ▲ 23.5-25, 20 PR L3
- ▲ 28L-26, 14 PR LS-2 (single-piece rim)
- ▲ 23.5 R 25, 1-Star L2 Radial
- ▲ 23.5 R 25, 1-Star L3 Radial
- 750/65 R 25, 1-Star L3-T Radial
- ▲ ▲ 26.5-25, 20 PR L3
- ▲ ▲ 26.5-25, 20 PR L5
- 26.5 R 25, 1-Star L3 Radial
- ▲ ▲ 29.5 R 25, 1-Star L3 Radial
- ● ● Five-piece rims
- ▲ ▲ ▲ Less wheels and tires
- ▲ 9-degree rear axle stops for extra-large tires, 12-degree oscillation for standard tires, 12-degree oscillation for standard tires, 12-degree oscillation for standard tires
- ▲ ▲ 8-degree rear axle stops for extra-large tires, 12-degree oscillation for standard tires

Other

- ▲ ▲ ▲ Full fenders, front, with mud flap
- ▲ ▲ ▲ Full fenders, front and rear, with mud flap
- ● ● Articulation locking bar (conforms to SAE J276)
- ● ● Vandal protection, includes lockable engine enclosure, rear grille, and fuel fill
- ● ● Counterweight, built-in
- ● ● Drawbar, with locking pin
- ▲ ▲ ▲ Transmission side frame guards
- ▲ ▲ ▲ Bottom guards, front frame and transmission
- ▲ ▲ ▲ Lift and tie-down hooks
- ▲ ▲ ▲ Fire extinguisher
- ▲ ▲ ▲ License plate bracket
- ▲ ▲ ▲ Secondary steering



JOHN DEERE

DKAJPLDR Litho in U.S.A. (05-02)

Net engine power is with standard equipment including air cleaner, exhaust system, alternator, and cooling fan, at standard conditions per SAE J1349 and DIN 70 020, using No. 2-D fuel at 35 API gravity. No derating is required up to 10,000-ft. (3050 m) altitude. Gross power is without cooling fan.

Specifications and design subject to change without notice. Wherever applicable, specifications are in accordance with ISO standards. Except where otherwise noted, these specifications are based on units with all standard equipment, one optional rear counterweight each; ROPS cabs; full fuel tanks; and 175-lb. (79 kg) operators; 724J unit with 23.5 R 25, 20 PR L3 tires; and 744J and 824J units with 26.5 R 25, 20 PR L3 tires.

