

610-2100-021
Rear Cab Rail
(left hand)

T-1 STEAM LOCOMOTIVE

1-8006 Reading

1-8011 Chessie System

(Page 1 of 3)

NOTE: For 1-8011 refer to L-3 Locomotive drawing for motor and worm shaft parts, constant lighting assembly, and headlight and firebox lamps.

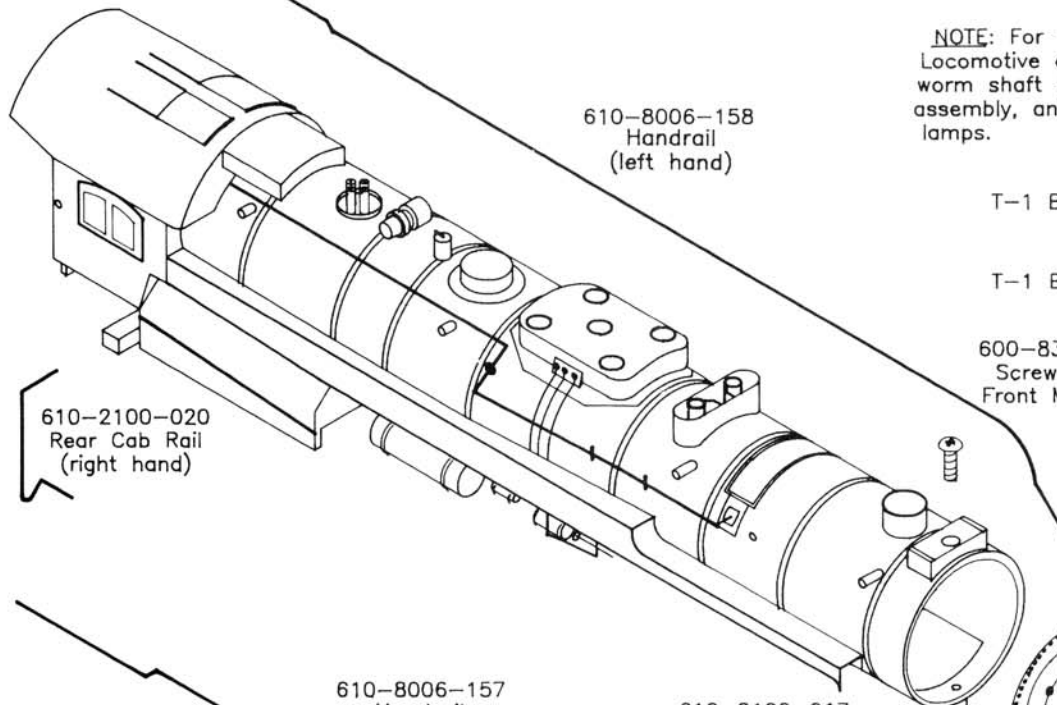

610-8006-158
Handrail
(left hand)

610-8006-002
T-1 Boiler Assembly Complete
(Reading)
610-2101-002
T-1 Boiler Assembly Complete
(Chessie System)

610-2100-020
Rear Cab Rail
(right hand)

600-8304-165
Screw Boiler
Front Mounting
610-2100-118
Bell Bracket
(Reading)
610-2101-021
Bell Bracket
(Chessie System)

610-8006-131 *
Wire Retainer

610-8006-157
Handrail
(right hand)

610-2100-017
Step (left hand)
(Reading)
610-2101-011
Step (left hand)
(Chessie System)

600-0348-187
Screw Bell
Bracket Mounting

610-2100-119
Bell

610-2100-025
Lens

690-2020-M09
Solder Lug

610-8006-130
E-Unit Plug

610-2100-016
Step Right Hand
(Reading)
610-2101-010
Step Right Hand
(Chessie System)

610-2100-024
Boiler Front Assembly
(Reading)
610-2101-020
Boiler Front Assembly
(Chessie System)
Includes: Bell; Bell Bracket;
Screw; and Lens

600-4300-065 *
Screw Brushplate
Mounting

600-0622-140 *
Brushplate Assembly

* Note parts marked with * are used on 1-8006 Reading only. For 1-8011 Chessie T-1 refer to L-3 drawing for motor and breakdown and plug assemblies.

610-8502-150
Motor Brush

691-8000-T60 *
Male Plug Assembly

690-671M-022 *
Retaining Clip

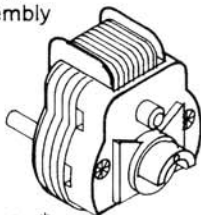

600-8606-112 *
Armature

690-671M-023 *
Thrust Washer

600-0681-121 *
Thrust Bearing

690-671M-023 *
Thrust Washer

600-8306-101 *
Motor Housing

600-0002-111
Lock Washer

600-8306-533
Screw Motor Mounting

690-671M-022 *
Retaining Clip

610-8006-026 *
Drive Coupling

T-1 STEAM LOCOMOTIVE

1-8006 Reading

1-8011 Chessie System

