

COLLECTING WITH **MAIAX**

Issue 30

August



COLLECTING WITH MARX

SUBSCRIPTION RATES:

\$18.00 per year

All subscriptions will be mailed on the same day with the same amount of postage to avoid unfairness in delivery. Mail dates will be the fifth day of every other month.

WITH EVERY SUBSCRIPTION comes a free ad of no more than 35 words with each additional word costing 10 cents.

CLASSIFIED ADS are 10 cents per word with a \$3.00 minimum and no maximum. Columns available are: Buy, Sell and Trade.

DISPLAY ADS:	Quarter page-----	\$10.00
	Half page-----	\$18.00
	Full page-----	\$30.00
	(Slightly higher if not camera ready)	

WE RESERVE THE RIGHT at COLLECTING WITH MARX to print or not print anything that comes into our office.

INCLUDE YOUR NAME, address and phone number with every ad or article. Nothing will be printed about you that you do not designate. If you do or don't want your name on an article or other submission just say so.

COLLECTING WITH MARX is not responsible for any errors, accuracy or problems you may have with advertisers in this newsletter. All photos, cartoons and articles will not be returned.

Collecting With MARX

7475 E. State Hwy YY

Springfield, Mo. 65802

417-866-1068

6-10 P.M. CST or leave message

FAX # 417-866-1068

Copyright 1998

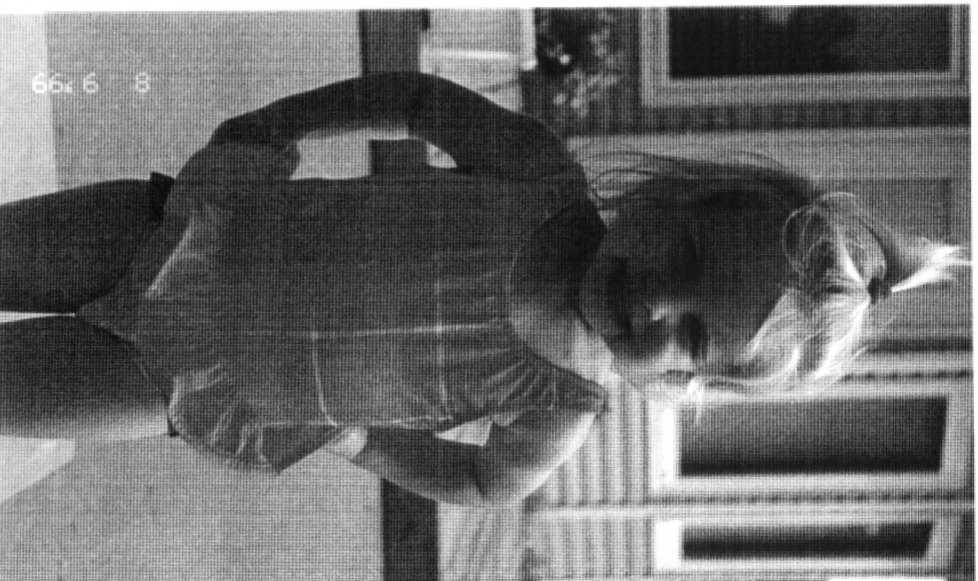
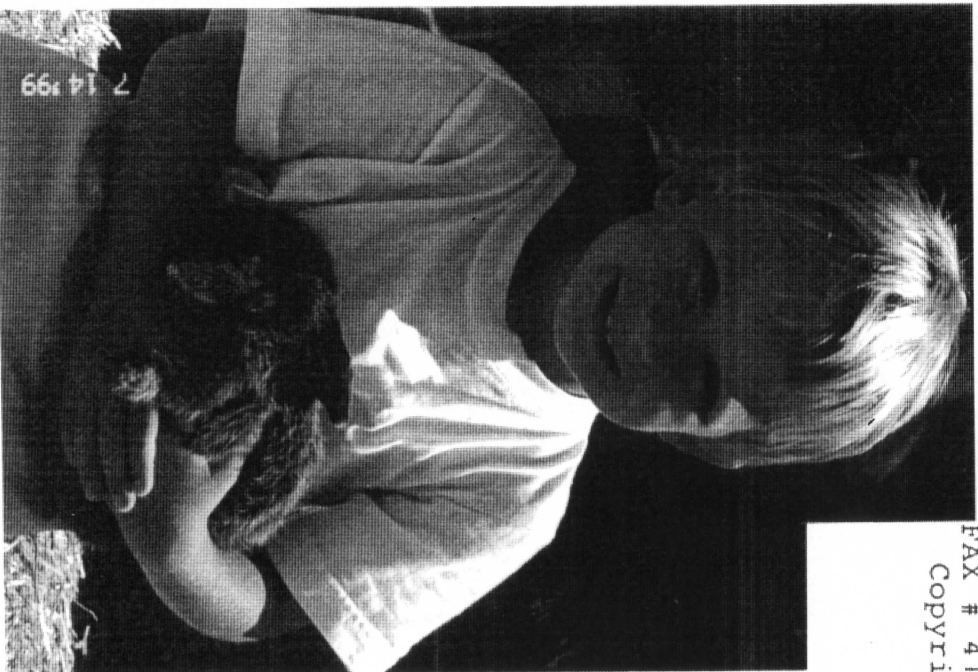

On the cover.....
Disneyland transfer train

Louis having fun at
Silver Dollar City
holding the bunny.

Bathing beauty Lauren Micah.

Summer is over in Springfield, as it is where you are. Time flies when you are having fun and time is surely flying at the Claussen household. We've been attending every park in Southwest Missouri and then some. We attended the Kansas City train show where I found a pink floor train engine-tender combo that wasn't in the greatest condition but how many do you find? I found it on Jim Norton's table and was glad to get it. The one I would really like to have is the four piece military floor train set that is extremely hard to find.

Since our last newsletter I bought three nice train toy pieces made in Swansea and I'll be sharing them with you in future issues of Collecting With MARX. I also bought the Disney piece on the cover which I feel is and extremely fun toy and am very happy to have found it.

I watch the internet nightly and haven't been able to buy much of anything! The only thing I have bought lately is the black cab for the Sears trailer with the red dot on the side of the cab. I have a couple but I always like a bargain and these are among my most favorite of all MARX trains or toys. I'll add it to a layout when we get our layout ready to go.

The internet is a great place to go to a "toy show". I see MARX toys I didn't even know existed and what really boggles my mind is what some are willing to pay for items that I am bidding on. It seems every time I bid on something I don't even get close to what someone is willing to pay.

Before I go any further I must explain an error I made last issue about the toys and airplanes that were shown from the April York show-and-tell. The pictures were taken by Bob Burgio and everything else belongs to others. The airplanes on the flat cars belonged to John Fox and the ones in the plastic bags belong to Bob Rosenberg. I still want to thank Bob Burgio for sending the pictures. We wouldn't have seen them at all if it wasn't for him. Subscribers to Collecting With MARX are definitely in the minority on the East Coast. Most subscribers are in places all across the country. We have also added a new subscriber in Germany. Welcome.

In the next issue I would like to ask you all to take a picture of your favorite MARX train or toy and write a paragraph about why it is your favorite and mail the picture and paragraph to Collecting With MARX at 7475 E. State Hwy YY, Springfield, MO., 65802. or fax to 417-866-1068 or E-mail it to louismarx@worldnet.att.net. Please feel free to contribute to your magazine and if you think of anything at all to send in please do so.

We are entering into the train collecting season and the holiday season is coming up too so please share your experiences current and past with your fellow readers. Let us know what you are finding and also consider sending a story about a Christmas past. Have fun and Happy Collecting!

M Marx

Walt Disney's-Disneyland Transfer Train

In the toy and train industry since the beginning of toy collecting, as most of us know it, Disney toys and trains have been among the most desired by collectors and will remain so unless something drastic happens. This "Transfer Train" was made in "The British Crown Colony of Hong Kong" and was purchased in England. The date of manufacture was 1971 and this particular Disney piece is in a lively colored box and the toy is plastic with a green base, a pink track, a blue "transfer" light and two yellow trains.

The trains circle the track and as Pluto is transferred onto the station platform Donald is boarding the train at the other end. This set has one too many figures and two Mickey Mouses may explain that one. Besides two Mickeys, Donald Duck and Pluto, this set contains Pinnochio, Minnie Mouse, Goofy and Jiminey Cricket. The set runs on two batteries and gives many hours of playtime fun. Toys like this one are hard to find in their original condition which may lead to their desirability.

These toys are some of my favorite things to collect. I like the different things of a more toy nature. If you have a special train or toy by MARX that you enjoy send me a picture and tell why you enjoy it.

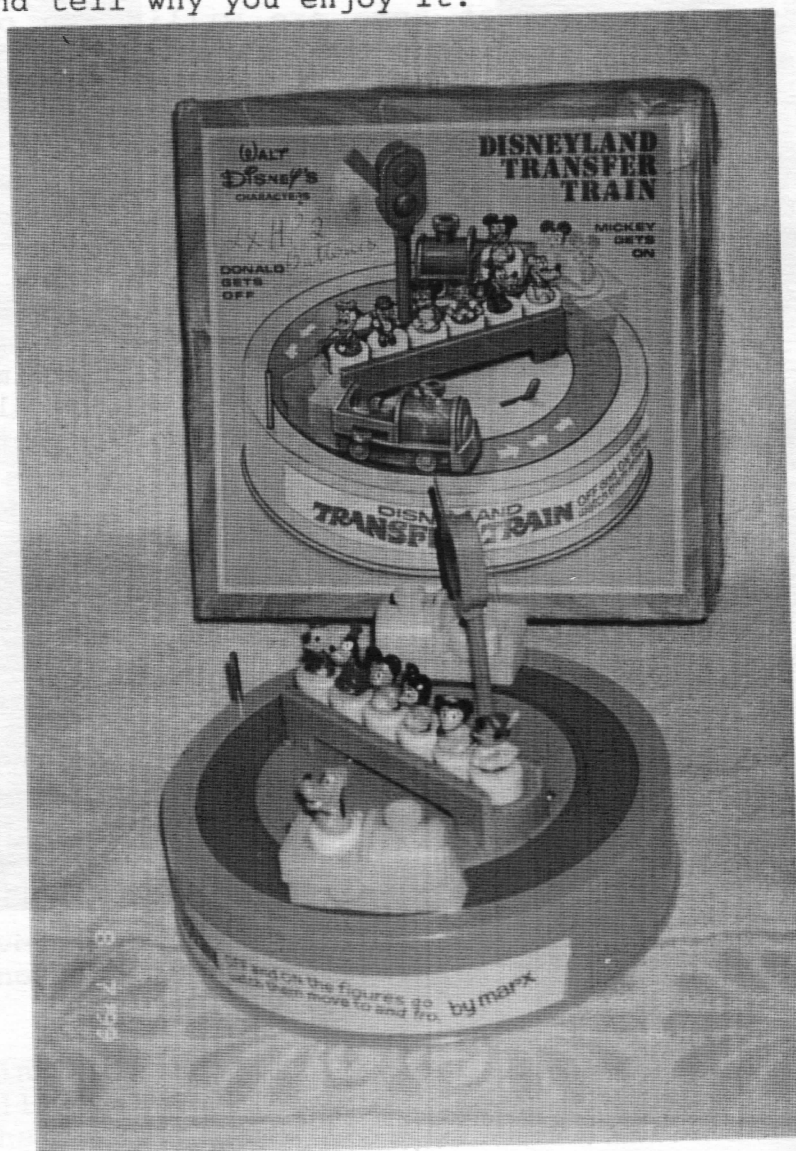

WATCH THE BIRDIE

By: James Norton

What does the new MARX train collectors have? A generally disregarded and ignored specialty car is the old time photography car. In the late 1800's and early 1900's, as towns grew up by the railroad tracks, there were few non-essential services available. One of these would have been the photographers shop where the family portrait could be taken. In the past, photographers out-fitted coaches, parlor cars and cabooses as studios, complete with dark rooms, backdrop scenes, furniture and lighting. These fancy rolling studios were pulled into a town, set on a siding and the entire country side and town came to have their pictures taken. When the business started to end, the train car would be hooked up to a passing train and taken to the next town.

As MARX collectors search thru the antique shops and flea markets for MARX items an associated artifact would be these old pictures. These pictures are generally sepia colored, fairly large and mounted on card board. They are usually identified as "Photo Car", Railroad Photo Studio, Palace car or some other identification as a railroad car. Most of them are interesting as they depict the dress, styles, furniture and habits of the era of the railroad empire builders.

In 1995 the TCA commissioned the new MARX train company to produce a Union Pacific RR Photography car as a convention car. Probably, the UPRR actually used a photography car to produce the large number of scenic railroad pictures for souvenirs, calenders, time tables and advertising. It's an interesting car that is a convention piece on a tin plate layout or display.

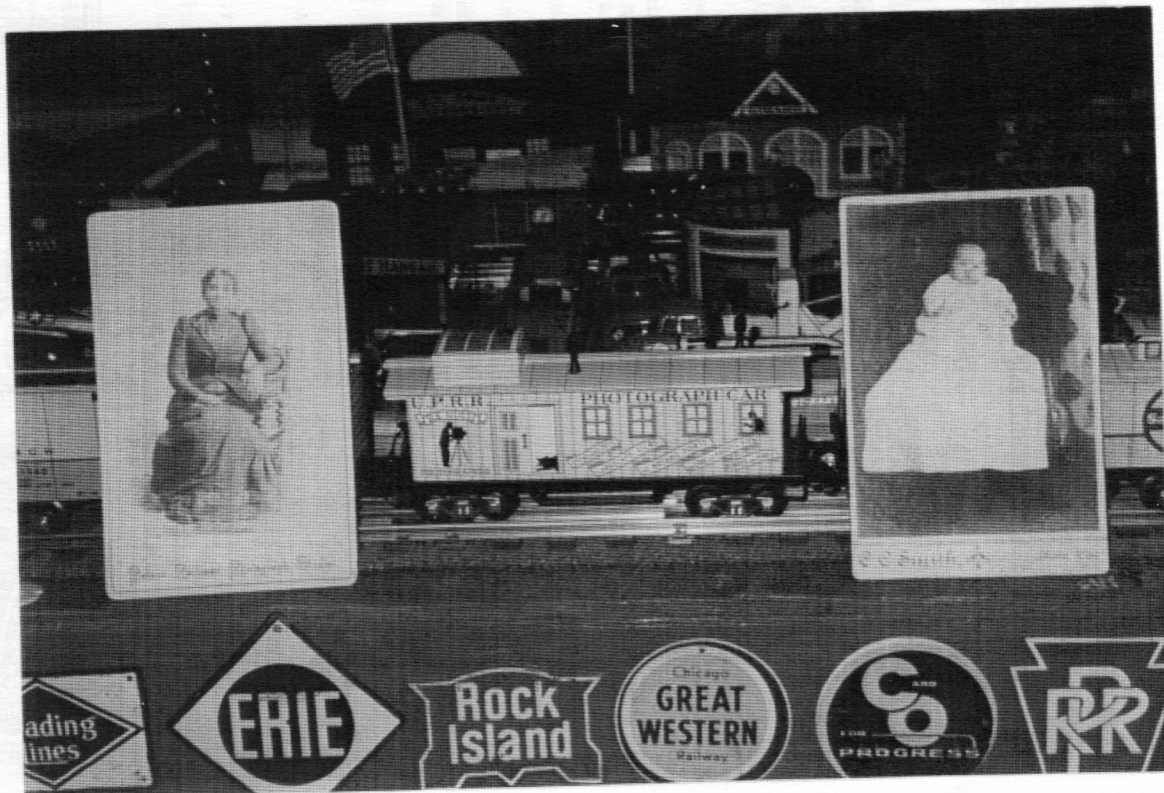

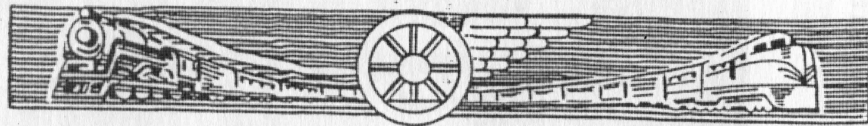

AET 255 — Coil Spring—For use in Latch Type Coupler. (Discontinued)

Price Each .04

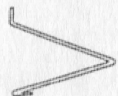

AET 785 — Track Uncoupling Spring — For use in the Track Uncoupling Unit.

Price Each .07

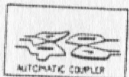

AET 726 — Tilting Spring — (Tilting Type Coupler) — For use in Undercarriage of Pullman and Freight CARS.

Price Each .04

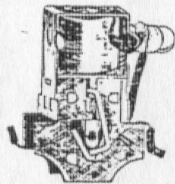

AET 3020 — Remote Unit — For use in all Marline Locomotives. Automatically changes direction of train, Forward and Backward.

Price Each .75

ATTENTION

When ordering please order by catalogue number. The parts listed in this catalogue are for use in the Four Wheeldrive Locomotive only. Prices listed herein are subject to change without notice.

Service Dept. 200 Fifth Ave. New York 10, N. Y.

CATALOGUE OF MARLINE REPAIR PARTS

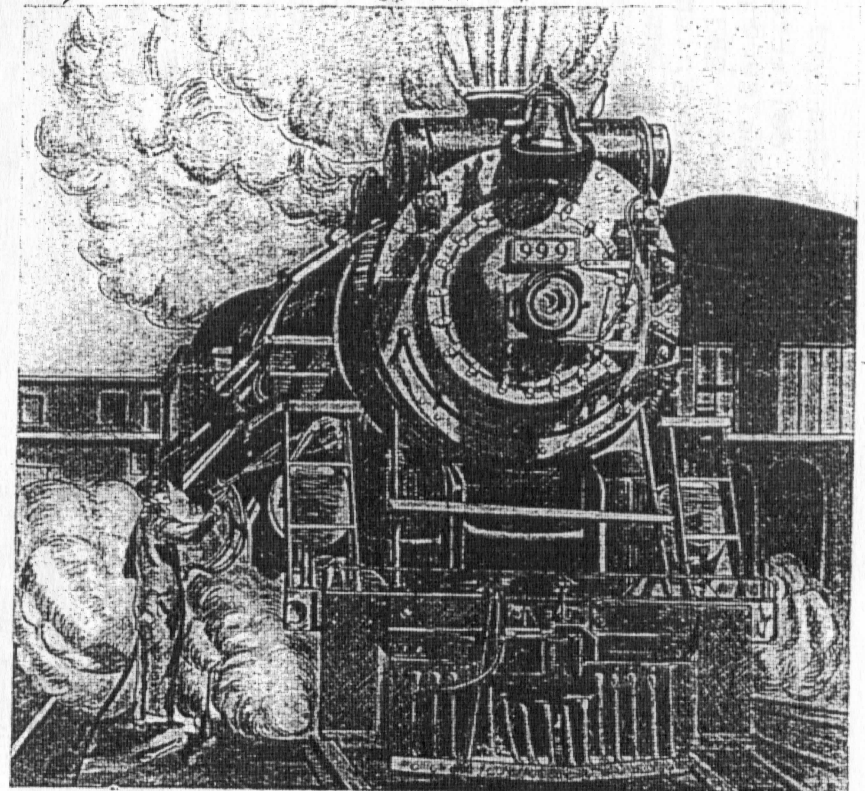

Louis Marx & Co. 200 Fifth Ave. New York 10, N. Y.

Contributed by
Glean Johnston

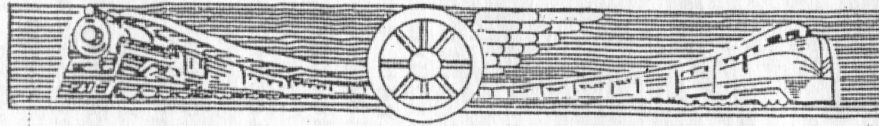

AET 24 — Pinion Gear — Steel Gear used on the end of Armature Shaft. Fits our Marx engines.

Price Each .11

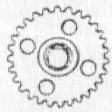

AET 27 — Intermediate Idler Gear—Will fit four-wheel drive Locomotive.

Price Each .16



AET 1086 — Armature Assembly — Complete with bronze oilless bearing, and pinion gear assembled.

Price Each .43

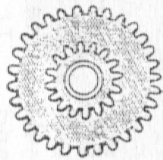

AET 305 — Compound Idler Gear — Use two (2) per motor. For use only on the low gear Sparking Locomotive. (Discontinued).

Price Each .22



AET 950 — Oilless Axle Bearing — Bronze and Brass Oilless Axle Bearings to fit all Marx engines.

Price Each .09

AET 25 — Driving Wheel Rear — With Piston Rod attached.

Price Each .09

AET 26 — Driving Wheel Front — Without Piston Rod.

Price Each .09

AET 37 — Drive Wheel Front — No Gear.

Price Each .09

AET 38 — Drive Wheel Rear — No Gear.

Price Each .09

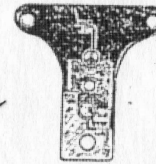
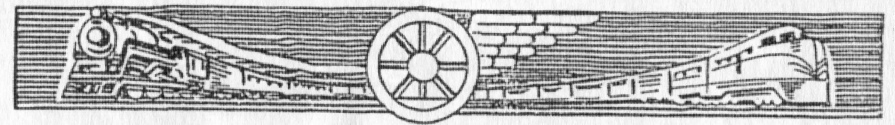
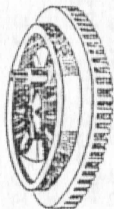

AET 1087 — Brush Holder Assembly — Consists of Fiber plate complete with Brush Holder, (two (2) Brush Springs and Bearing Oil Wicks.

Price Each .24



AET 1018 — Trolley Shoe Assembly — Third rail contact. Will fit all four-wheel drive Locomotives.

Price Each .37



AET 56 — Trolley Shoe — Replacements will fit the above Trolley Shoe Assembly.

Price Each .11

STEEL CAR WHEELS (Pullman & Freight)



AMT 1070 — Double Truck — 8 wheels.

AMT 1121 — Four-Wheel Trucks.

Price Each .03



AMT 253 — Wheel Axle—Wheel Axle fits all Marx Cars.

Price Each .01



AET 321 — Motor Brush — Made of carbon to fit Brush Holder Assembly. For use in all types of Locomotives.

Price Each .08



AET 308 — Brush Spring — Used to hold proper tension on carbon brush.

Price Each .07

You asked in the last issue of CWM. Whats next in the MARX community?

As you can see we will do anything (photo) for MARX trains. I had to stop standing on the corners, though.

I have been living in Houston for 52 years - and never realized there were so many streets - named "Walk & Wait". I kept getting lost and finally had to give it up. - Roland Williams.



THE PROBLEM WITH
QUICK-DRYING GLUE

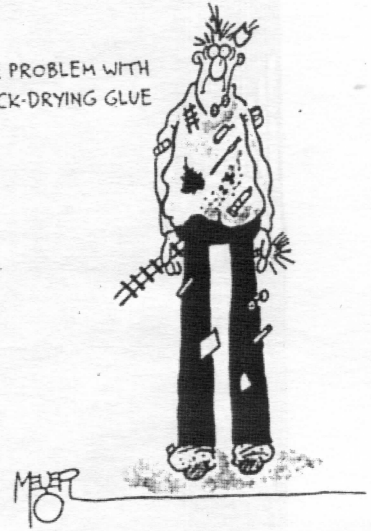

Cartoon sent by Ray Cox.

I wonder if any of your readers could help in determining how many color schemes the Tricky Taxi came in? I have all that are listed in book except the purple. I also have a red and yellow without the checkers, for a total of 8.

They are:

WITHOUT CHECKERS

red & yellow
red & white
black & yellow
black & white

WITH CHECKERS

red & yellow
red & white
orange & white
green & white

Thanks ---Kenneth Barnes.

A friend of mine found this ad for MARX trains in an automotive supply catalog. I found the Army train to be a very neat item with the contents. I can't find any info on this item. I'm wondering what the engine is? I figure it may be a 897. The ad was from 1941 and states first time reversible windup. My books show me the 897 from 1940 with a reversible motor. The picture doesn't show any lithograph but it has the same configuration as the 897. The army barracks looks to me like the set box and the soldiers look like the small metal ones with numbers on the bottom. I just thought this might be an interesting picture to put in Collecting With MARX. About the only thing I have found lately is a British M10000. It is maroon and silver. I purchased it at the St. Charles (Illinois) toy show from a gentleman from England. It consisted of the engine, coach and coach buffet. It's in pretty nice condition. Keep up the work with your fine publication. I look forward for each issue. --Jim McGinnis.

MARX STREAMLINED "WIND-UP" TRAINS

Freight, Passenger, and
New Army Types with Powerful
Wind-Up Motors! They're Honey's!

Modern Steam
Type REVERSIBLE
Locomotive
First Time in Me-
chanical Trains!

5-Unit Military Train with Barracks \$2.98

All the fix'n's to set up your own army post! The NEW reversible locomotive whizzes around the track to the army barracks, pulling a tender, searchlight car with real-looking light, a radio car, and a mounted anti-aircraft gun! The anti-aircraft gun really shoots—and carries its own shells on the flat car! The barracks are complete with 8 standing American soldiers, and a flagpole standard with flag. There is a mechanical switch with dead end track, 9 curved, and 7 straight track sections. 36 inches long. Ask for Number 72.

A 5 Units—and
IT WHISTLES!

Freight Train \$1.98

The famous "Commodore Vanderbilt"—sleek and shiny—with a red and black locomotive, tender, tank car, side dumping car, and caboose! It whistles loud and clear as it roars along—and sounds for all the world like a real freight! 12 curved and 4 straight track sections with a cross-over piece. Train measures 35½ inches. Ask for Number 71.

B 28½ In. Passenger \$1.19

Real sparks fly as the "Commodore Vanderbilt" speeds down the track! It has a gleaming black locomotive, tender, and three red coaches, 10 track sections! Number 70.

C 28½ In. Freight \$1.19

The "Commodore Vanderbilt" spark-shooting locomotive with bell . . . pulling a tender, gondola, and caboose! It's a beauty—with 10 track sections. No. 69.

Watch the real sparks fly
as these streamliners zip
down the track!

In issue 29 you have a nice article about MARX civilian and military planes. I assume civilian means holes for windows and canopy for military. You ask about a civilian olive drab plane because you have never seen one. Back in issue 20 I wrote and asked if clips under the wings were to carry a bomb load. You said they were and they carried wooden bombs. Here is a picture of my plane. It is a civilian olive drab plane and it has the clips for the bombs. I bought it in an antique mall but it didn't come on the flat car. The silver bombs under the wings are repro, but everything else is original.

I have a yellow and brown M10005 wind-up diesel power engine. It has the tab and slot freight coupler factory rivited on the back instead of the pin for the articulated sets or the dog bone coupler. It looks like the (732 GMD) electric, white and green with freight coupler. Greenbergs price guide does not mention it or give it a number. I know there are other things missing in the price guide too, but wonder how rare or common this piece is and what number it may be. Have you seen this one, or know the number, or how rare or common it may be? What is the value of the diesel? I've only seen one other in someone elses collection and he doesn't know either.

In June I went to the great midwest train show in Chicago area and seen a very good 5 piece Mickey Mouse Meteor for \$1200. To rich for me, so all I could do was drool! Stopped at a few antique malls on the way back to Green Bay and found another 5 piece set for \$400. Just as nice. I now own a Mickey Mouse Meteor! You seldom see one for sale and then see two in the same day!

Sometime could you write about the flat tin litho MARX soldiers. How many different kinds, what they are, which are harder to find, and values. I've been trying to collect them to display with my military trains but have little to go by. I don't know which I'm missing or if I'm paying to much. --Jerry Wixon.

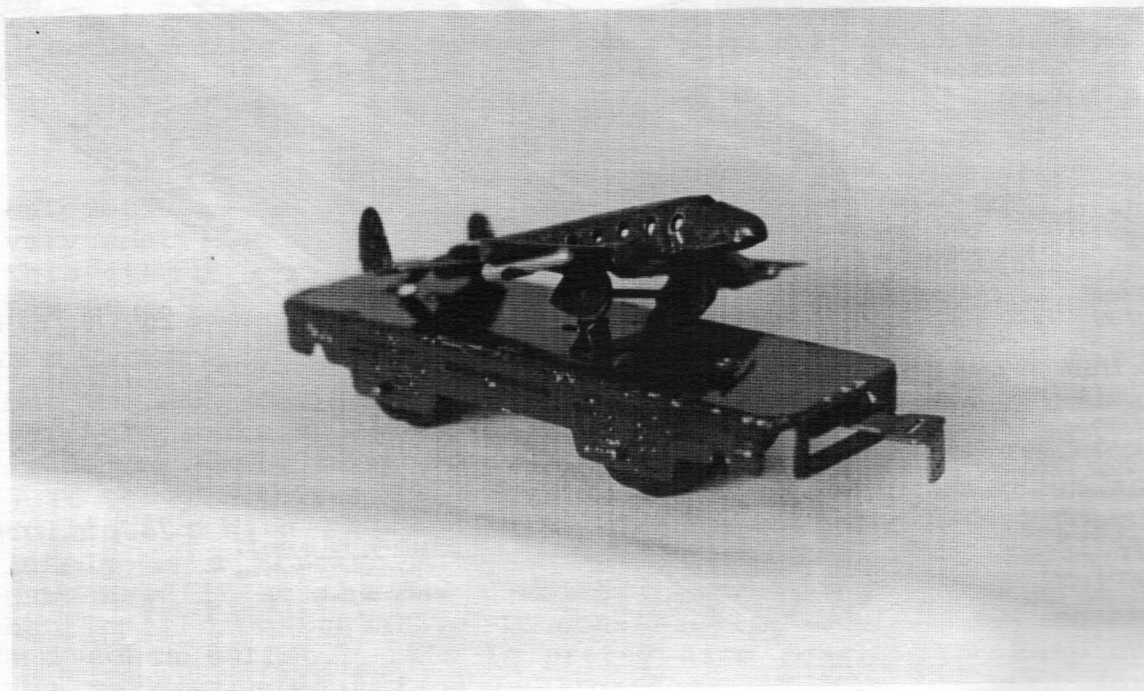

Mark your calendars for the 2nd annual MARX toy and train collectors national convention. Friday and Saturday June 16 and 17, 2000. The convention takes place in Wheeling, W.V. at the Kruger Street Toy and Train Museum!

FOR SALE

MARX 7" COLLECTION-5 SETS, 8 ENGINES, 18 CARS, 12 SWITCHES, 50 ACCESSORIES, 3 TOYS, INCLUDED- MICKEY MOUSE TRAIN, WILLIAM CROOKS WIND-UP SET - M/B, HONEYMOON EXPRESS. PLEASE SEND SAE (NO STAMPS) FOR LIST: WILLIAM KILBORN, 197 WIDDER STREET EAST, ST. MARYS, ONTARIO, CANADA. 519-284-3052.
Zip code: N4X 1B4

WANTED

548 CRI&P Guernsey Milk with milk can load and 4 wheels, 46010 SSW, 4 wheel, any color except red. phone:204 339-2513. Louis Rodkin.

-
1. KC Southern caboose tin.
 2. Need B&O cabooses #504, #517.
 3. Fruit Growers Express 6" reefers.
 4. Pacemaker Freight 6" boxcars.
 5. English Green Link Set.
 6. English Joyline cast iron engine
 7. 6" flat for #5 Army tank.
 8. All red 6" 8 wheel log car.
 9. Red 994 style engine and tender.
- Marx Claussen, 7475 E. State Hwy YY, Springfield, MO., 65802. Call 417-866-1068 evenings 6-10pm central.

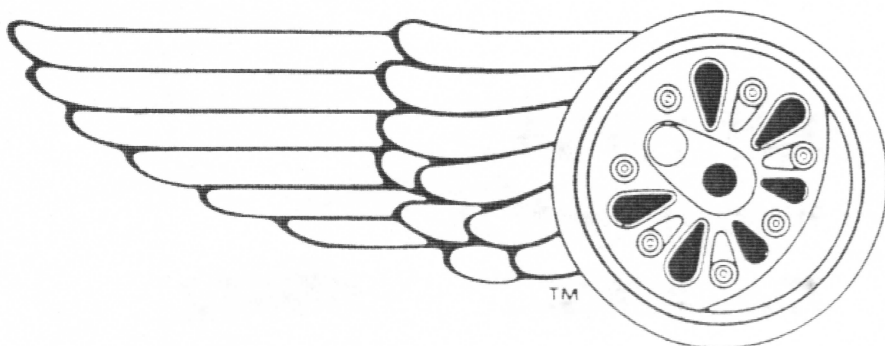

**The
Robert
Grossman
Company**

1967 CHELFORD RD. RICHMOND HTS. OHIO 44143
PHONE # (216) 738-0602 FAX # (216) 738-0603
NEW MARX TRAIN PARTS CATALOG \$ 4.00



209 E. BUTTERFIELD ROAD • #228 • ELMHURST, IL 60126
TEL: (630) 941-3843 FAX: (630) 941-3829 • e-mail marxusa@aol.com
<http://www.choicemall.com/marxtrains/> and <http://www.trainexchange.com/marx.htm>
Adult collectibles - Not intended for children

COLLECTING WITH MARX
7475 E. State Hwy YY
SPRINGFIELD, MO. 65802



~~XXXXXXXXXX~~
~~6936 Skaneateles Ave~~
~~XXXXXXXXXX MN 55417~~