

WIRING THE # 57 SWITCH CONTROLLER

ATLAS SWITCH
MACHINE # 6099 OR 65

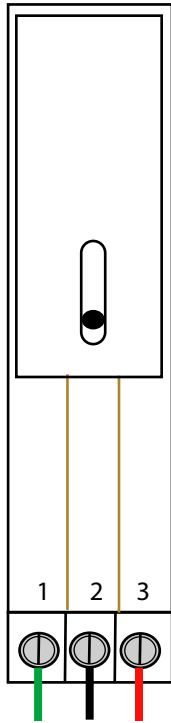

FOR ADDITIONAL WIRING PLANS PLEASE VISIT THE
ATLAS MODEL RR WEBSITE (ATLASRR.COM / SUPPORT)

ATLAS # 200 SNAP RELAY
OR # 6098, 2065 OR #66
DELUXE UNDER TABLE
SWITCH MACHINE

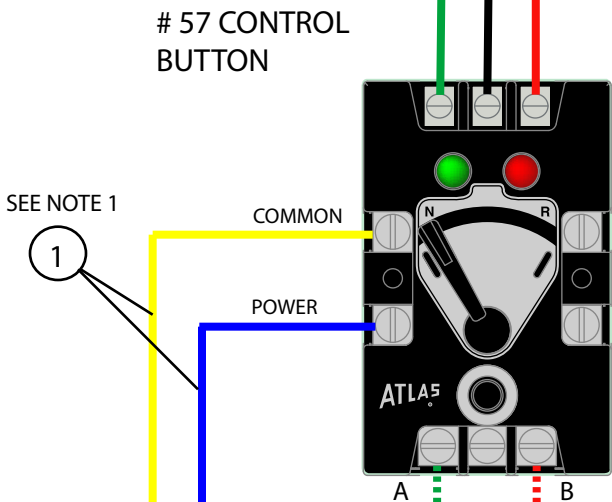

SEE NOTE 1
1

SOLID LINES
REPRESENT STANDARD
WIRING, LED'S FOLLOW
LEVER POSITION

DASHED LINES REPRESENT
OPTIONAL WIRING TO EXTERNAL
RELAY CONTACTS SUCH AS # 200
SNAP RELAY OR DELUXE UNDER
TABLE SWITCH MACHINES # 66 OR # 6098
THIS WILL PROVIDE LED ILLUMINATION
TO FOLLOW SWITCH THROW

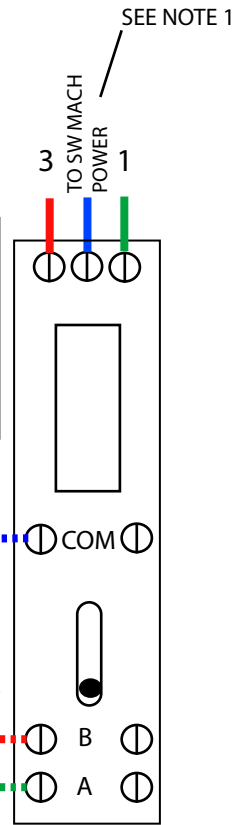

TO NEXT
57 CONTROL
BUTTON

TO POWER
SUPPLY

TO # 57 CONTROL
BUTTON TERMINALS
"A" & "B"

ATLAS O 80 WATT	LIONEL ZW	MTH Z4000	ATLAS 311	ATLAS O 30 WATT
B	B/C	14VAC	ACC	A
U COMMON	U COMMON	U COMMON	COM	U

NOTE 1
WHEN WIRING FOR LED'S TO FOLLOW
THE SWITCH THROW, REMOVE BLUE WIRE
(POWER) FROM SCREW TERMINAL. SWITCH
MACHINE POWER SHOULD BE WIRED
DIRECTLY TO CENTER SCREW TERMINAL
OF SWITCH MOTOR. COMMON OR GROUND
(YELLOW) WIRE SHOULD BE MOVED TO
TERMINAL WHERE POWER HAD BEEN
CONNECTED.