



DIESEL/ELECTRIC LOCOMOTIVE UPGRADE KIT

INSTALLATION MANUAL BETA EDITION

Compatibility

This Proto-Sound 3.0 Diesel/Electric Locomotive Upgrade Kit is compatible with any AC or DC Powered locomotive equipped with a DC can motor(s) and motor flywheel(s). The locomotive must be large enough to house the electronics. The instructions herein are generic in nature and will not provide the installer with specific installation details for specific locomotives. Consult the individual item's operator's manual for specific instructions on how to disassemble the locomotive prior to installing the upgrade kit.

WARNING: This product is not covered by a warranty unless installed by an M.T.H. Authorized Conversion Center.

PLEASE READ BEFORE USE AND SAVE FOR REFERENCE
www.mthtrains.com

Table of Contents

Contents Of The Kit	3
Required Tools	6
Upgrading Multiple-Unit Diesels	7
Inspection & Review	8
Preparing The Chassis For The Proto-Sound 3.0 Upgrade	9
Installing The Proto-Sound 3.0 Components Onto The Chassis	10
Mounting The Proto-Sound 3.0 Board	11
Installing The DCS/DCC Switch	14
Installing The Proto-Couplers	14
Proto-Sound 3.0 Chassis Wiring Diagram	16
Installing The Chassis Harness, Speaker & Smoke Pot	18
Soldering Speaker Connections	19
Installing The Volume Pot	20
Installing The Tach Reader Bracket	21
Installing The Flywheel Tach Tape	21
Mounting The Tach Reader To The Tach Bracket	22
Connecting Motor, Ground & Pickup Wires	23
Connecting Lights (LEDs)	24
Connecting The Proto-Sound 3.0 Harness To The Smoke Unit	25
Wire Management/Short Circuit Prevention	26
Testing The Proto-Sound 3.0 Installation	27
Loading The Proto-Sound 3.0 Sound File Into The Upgraded Engine	28
Proto-Sound 3.0 Operation Instructions	31
Conventional Operation	31
Troubleshooting	37
Service & Warranty Information	40
Warranty Coverage & Service Options	40
Limited 90-Day Warranty	40

WARNING: This product is not covered by a warranty unless installed by an M.T.H. Authorized Conversion Center.

CAUTION: ELECTRICALLY OPERATED PRODUCT:

Recommended for Ages 14 and up. Not recommended for children under 14 years of age without adult supervision. As with all electric products, precautions should be observed during handling and use to prevent electric shock.

WARNING: When using electrical products, basic safety precautions should be observed, including the following:

- Read this manual thoroughly before using this device.
- M.T.H. recommends that all users and persons supervising use examine the hobby transformer and other electronic equipment periodically for conditions that may result in the risk of fire, electric shock, or injury to persons, such as damage to the primary cord, plug blades, housing, output jacks or other parts. In the event such conditions exist, the train set should not be used until properly repaired.
- Do not operate your layout unattended. Obstructed accessories or stalled trains may overheat, resulting in damage to your layout.
- This train set is intended for indoor use. Do not use if water is present. Serious injury or fatality may result.
- Do not operate the hobby transformer with damaged cord, plug, switches, buttons or case.

This product may be protected by one or more of the following patents: 6,019,289; 6,280,278; 6,281,606; 6,291,263; 6,457,681; 6,491,263; 6,604,641; 6,619,594; 6,624,537; 6,655,640.
©2016, M.T.H. Electric Trains®, Columbia, MD 21046

Contents Of The Kit

- A) Proto-Sound 3.0 Board and Plastic Bracket
- AA) Proto-Sound 3.0 Heat Sink Bracket Kit
- B) Mars/Ditch (LED) Light (4)
- C) Proto-Coupler (2)
- CC) Coupler Insulator (2)
- D) Backup Light (LED)
- E) Marker Lights (LED) - Red
- EE) Marker Lights (LED) - Green
- F) 40-Pin Chassis Harness w/Tach Reader, Vol. Pots, DCS/DCC Switch
- FF) Tach Reader Bracket
- FFF) Tach Tape
- G) Headlight
- H) Speaker
- I) Recharging Port Hardware Spacers (2)
- J) Interior Lights (LED)
- K) Overhead Blinking Light
- L) 6/32 x 6mm Screws (3)
- M) 6/32 Nuts (3)
- N) Shrink Tubing
- O) Wire Management Coil
- P) Wire Ties (6) 4"
- Q) Wire Nuts (2)
- R) Speaker Plug
- S) 8-Pin Chassis Harness

(A) Proto-Sound 3.0 Circuit Board
AI-1000034

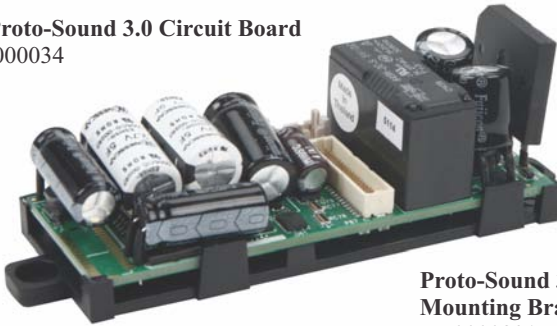

Proto-Sound 3.0 Plastic Mounting Bracket
IH-0000391

(AA) Protosound 3/2 Heat Sink Bracket Kit
IC-0000026
(includes heat sink bracket, board mounting bracket and 2 screws)



(C) Proto-Coupler (2)
DD-0000032
(without wires)



(B) Mars/Ditch (LED) Light (4)
CE-2000002



CC) Coupler Insulator (2)
ID-0000123



(D) Backup Light (LED)

CE-2000005



(E) Marker Light (LED) - Red

CE-2000004

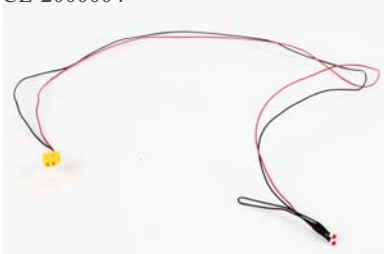

(EE) Marker Light (LED) - Green

CE-2000003

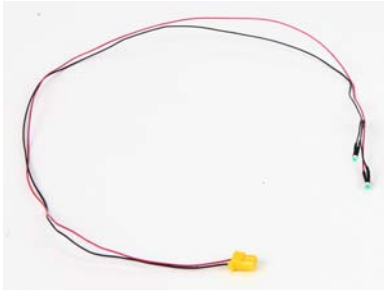

(F) 40-Pin Chassis Harness w/Tach Reader, Vol. Pots, DCS/DCC Switch

BC-2000006

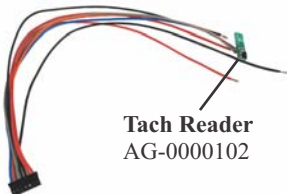

Tach Reader
AG-0000102

(FF) Tach Reader Bracket (27mm Flywheel) (pictured below)

IH-0000475

Tach Reader Bracket (30mm Flywheel) (not pictured)

IH-0000478



(FFF) Tach Tape

BE-0000151

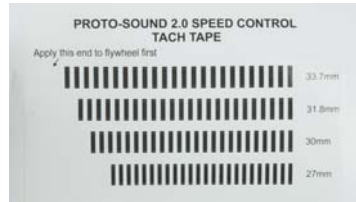

(G) Headlight

CE-2000006

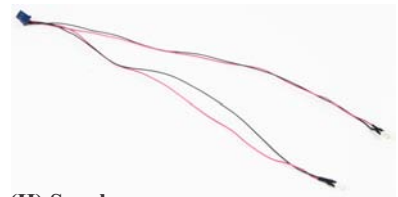

(H) Speaker

BF-0000034



(I) Recharging Port Hardware
Spacers (2)
ID-0000071
Screw (2)
IA-0000035
Nut (2)
IC-0000006



(J) Interior Lights (LED)
CE-2000007



(K) Overhead Blinking Light
CE-2000008

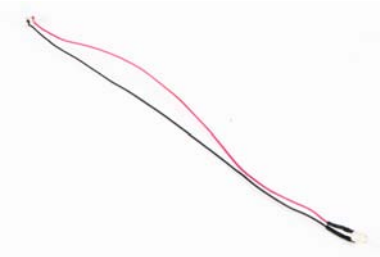

(L) 6/32 x 6mm Screws
IA-0000027



(M) 6/32 Nuts
TP-MS00075



(N) Shrink Tubing
12" - IH-0000464

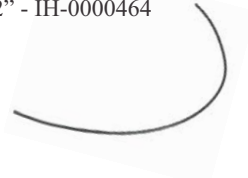

(O) Wire Management Coil
6" - IH-0000465
1' - IH-0000466



(P) Wire Ties



(Q) Wire Nuts
BI-4500003



(r) Speaker Plug
BC-0000008



(S) 8-Pin Chassis Harness
BC-2000009



Required Tools

- Soldering iron
- ESD safe work area
- White thermally conductive grease
- Screw drivers, Philips #2 & #00
- Wire cutters
- Drill
- Drill bits (1/8", 5/32")
- Drill bit (3/8" or 1/2") or de-burring tool
- Electrical Tape
- Razor Saw

What Is An ESD?

As ESD safe work area is an area set aside in your workshop that is electrically grounded and includes anti-static mats and grounding straps

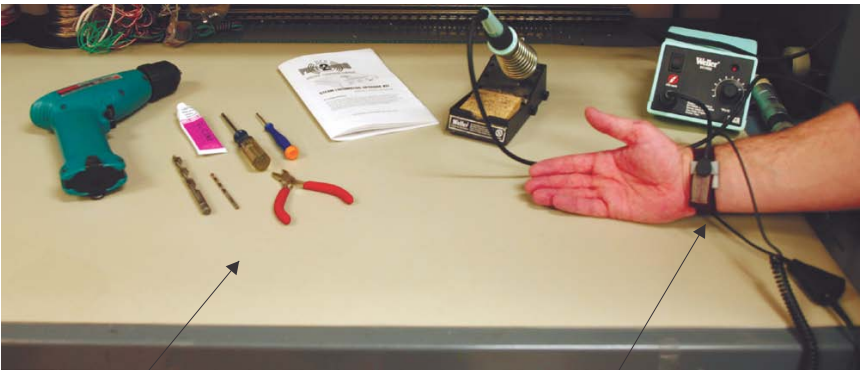

ESD Mat

Work Only in an ESD Safe Zone

Grounding Strap

Upgrading Multiple-Unit Diesels

This kit is designed for single diesel or electric locomotives only. There is no provision for wiring a coupler and/or back-up light into a dummy or non-powered trailing unit. Similarly, the kit does not provide a way to control powered trailing units. See the note below on four-motored locomotives as serious damage can occur to the Proto-Sound 3.0 electronics if warnings are not heeded.

Four-Motored Locomotives

This kit is designed to upgrade only a single locomotive with one or two motors. Engines with four motors in two separate body shells will require two upgrade kits - and thus become two separate Proto-Sound 3.0 locomotives that can be operated as a lash-up or as separate units.

Warning: Attempting to run three or four motors off of a single Proto-Sound 3.0 board will damage the motor drive circuit and require board replacement.

Lighting In Non-Powered Units

This kit does not provide connections for lights in non-powered (dummy) units. Non-powered Proto-Sound One units with constant-voltage lighting boards will work under DCS with no modifications. If the non-powered trailing unit is equipped with lighting (ie: back-up light) that is connected to the powered unit through a harness, you can use that existing harness to connect those lights up to the Proto-Sound 3.0 kit.

Proto-Couplers In Non-Powered Units

This kit does not provide connections for Proto-Couplers in non-powered (dummy) units, although it does include two Proto-Sound 3.0 Proto-Couplers. ***Note: Original Proto-Sound Proto-Couplers will not work consistently with the Proto-Sound 3.0 board. The original Proto-Sound Proto-Couplers require higher voltage to operate and therefore do not open consistently when commanded with the Proto-Sound 3.0 board.*** If your unit came with a Proto-Coupler on the non-powered trailing unit, you can use the existing harness to connect the newly installed Proto-Coupler on the trailing unit.

Inspection & Review

Before beginning the installation, Inspect the engine to be upgraded and verify the following are in good working order:

- Pick-up rollers
- Motor w/flywheels
- Smoke unit (*if equipped*)
- Speaker mounting hardware
- Volume pot
- Coupler mounting hardware, “T” bar, spring, c-clip
- Constant voltage lighting board and connected bulbs.

Note: If any of the above items are missing or not in working order, procure the required parts before continuing.

Note: It might be helpful to label the Front and rear of the chassis as a reminder which direction the engine should first move when powered up.

Note: Before beginning installation, see discussion on page 26 on “wire management” which should be planned as you proceed during the installation. Part of the plastic wire tube (Q) may be used for this purpose.

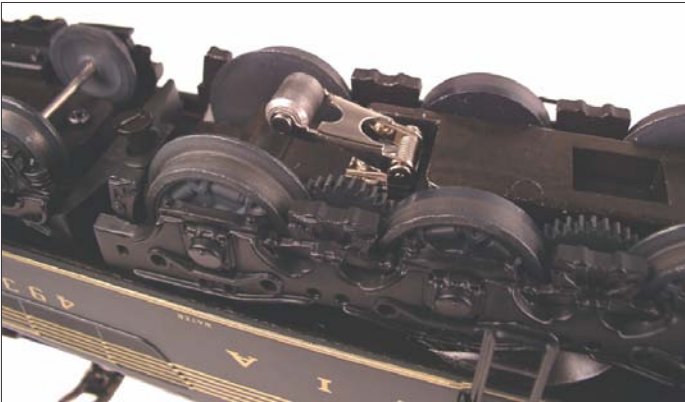

Make sure pickup rollers are clean and roll freely.

Preparing The Chassis For The Proto-Sound 3.0 Upgrade

Before you can install the Proto-Sound 3.0 components into your locomotive, any existing sound boards or reversing units must be removed. The Proto-Sound 3.0 Kit contains all the necessary electronics your locomotive requires to operate. Some existing mounting brackets may be utilized during the installation of the Proto-Sound 3.0 components. Follow the instructions below taking care to save the parts when noted.

Remove The Following Items From The Locomotive Chassis

- Body shell (save the mounting screws).
- Proto-Sound 1, DCRU Reverse Unit, Mechanical Whistle, Electronic Whistle, any other electronics and harnesses.
- Speaker (save mounting hardware).
- Existing couplers (save the “T” bars, springs, and c-clips).
- Any lights including the headlight and marker LEDs (if present). These will likely be mounted inside the body shell.
- Volume pot or smoke unit ON/OFF switch (if present).
- Battery Charge Jack (if present) and retain screws.
- Do **NOT** remove red wires connected to pickup roller assemblies. (Inspect the wires and replace with wires supplied in the kit as needed.)

Note: Leaving a short piece of color coded wire on each motor terminal will help ensure that the new motor wires are hooked up to the correct motor Terminals and allow each motor to run in the same direction.

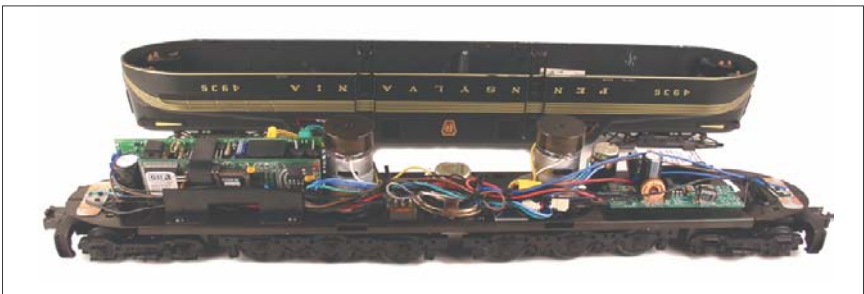

Installing The Proto-Sound 3.0 Components Onto The Locomotive Chassis

Once the existing electronic components have been removed from your locomotive, begin locating the best mounting position for the Proto-Sound 3.0 components. The major components are the Proto-Sound 3.0 board, Proto-Sound 3.0 Heat Sink Bracket, the speaker and the rechargeable battery pack. The speaker can often be installed in the fuel tank (if your locomotive is so equipped) leaving the chassis areas in front of, between, and behind the motors for the remaining Proto-Sound 3.0 equipment.

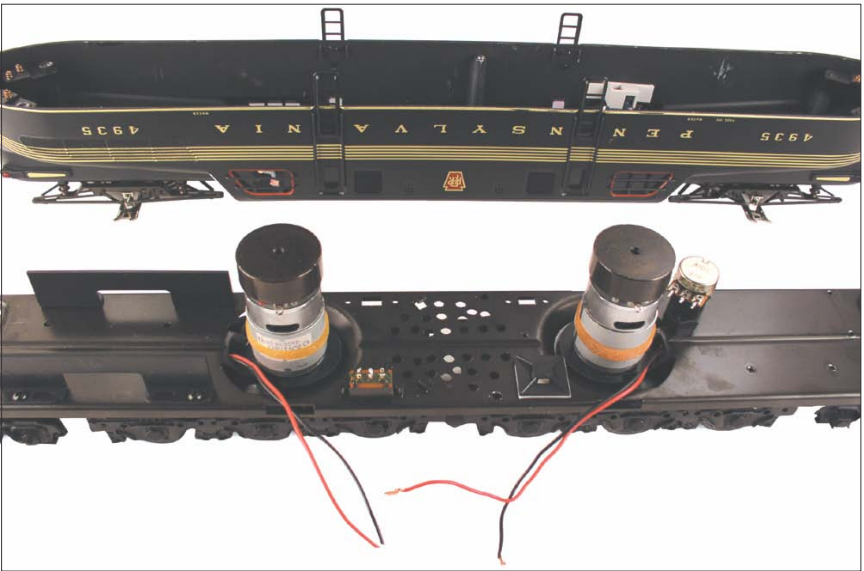

This Premier Line GG-1 features no fuel tank, so the speaker must be mounted onto the chassis.



Typical component arrangement on tender floor. Note position of heat sink.

Mounting The Proto-Sound 3.0 Board

- Remove the Proto-Sound 3.0 Board (A) from the sealed anti-static bag
- Verify Proto-Sound 3.0 board is securely inserted into its plastic mounting bracket.

NOTE: If you are not a participating MTH Authorized Service Center there is NO warranty once the bag is opened.

NOTE: Use ESD safe work area and procedures when handling the Proto-Sound 3.0 board.



Make sure the Proto-Sound 3.0 board is firmly inserted into the plastic mounting bracket. If not, gently push the board into the bracket until fully “captured” by the bracket. DO NOT REMOVE THE BOARD FROM THE BRACKET.



- Remove the speaker (H) from the protective packaging.
NOTE: Be careful not to damage the speaker cone

Place the components on the chassis floor in the best position given the space.

- Place the Proto-Sound 3.0 board/plastic mounting bracket (A) on the chassis to verify the best location to mount the plastic mounting bracket and the metal heat sink bracket (AA) to the chassis.

Mounting The Proto-Sound 3.0 Board *Cont'd*

- Once you have determined the best locations for mounting the Proto-Sound 3.0 Board bracket (A), metal heat sink bracket (AA), mark the chassis floor locations using a pencil or silver marker so you can drill the holes in the proper locations. If necessary, determine the location of the smoke unit switch as well.

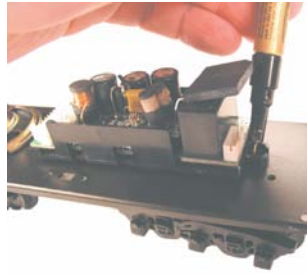

Drill the appropriate mounting holes as determined from positioning the Proto-Sound 3.0 board and other components

- Remove the Proto-Sound 3.0 board with plastic mounting bracket (A), metal heat sink bracket (AA), and speaker from the chassis and place on an ESD safe area on your workbench. Removing the motors & trucks will help protect them from any stray metal chips when drilling mounting holes.
- Drill the holes as marked with the proper drill size. A 5/32" bit will be required for the Proto-Sound 3.0 plastic mounting bracket (A) and heat sink bracket (AA).
- De-burr the holes slightly using a larger drill bit (3/8") or a deburring tool. Clean all metal burrs or chips from the chassis before proceeding.

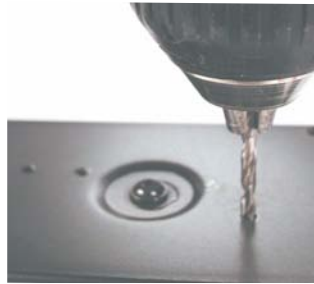

Carefully remove any metal burrs resulting from drilling the mounting holes. Loose metal burrs can damage the Proto-Sound 3.0 circuit board!

Mounting The Proto-Sound 3.0 Board *Cont'd*

- Mount the plastic mounting bracket (A) containing the Proto-Sound 3.0 board using 2 of the screws (L) and nuts (M)

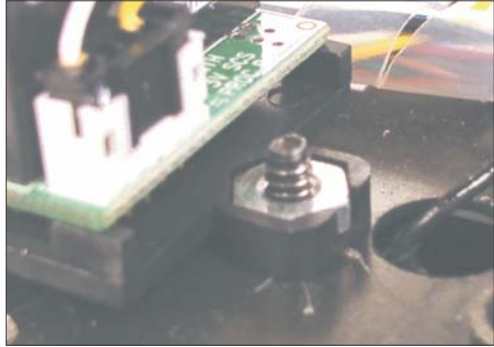

Mount the Proto-Sound 3.0 plastic mounting bracket

- Apply white thermally conductive grease to the bridge rectifier on the Proto-Sound 3.0 board.



Apply white thermally conductive grease to bridge rectifier & the mounting spot for the metal heat sink bracket.

- Secure the metal heat sink bracket (AA) to the bridge rectifier using screw (AA)

Note: If screw is too long, cut it down so it does not hit the relay

- Secure the heat sink bracket to the chassis floor using screw (L) and nut (M).

Note: The screw comes up from the bottom of the chassis.

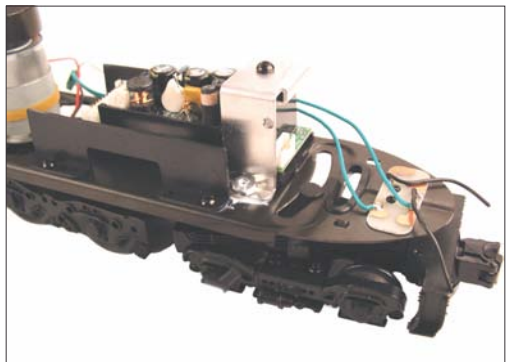

Installing The DCS/DCC Switch

Remove the existing Battery Charge Jack and retain the screws. If the switch fits into the opening then secure it to the chassis with at least one of the screws. However, in most cases it will not fit. Therefore, you will need to set the switch to the desired setting (DCS or DCC) BEFORE you re-assemble the model. Additionally, you will need to wrap electrical tape around the switch contacts to ensure they do not short to anything in the model.

Alternatively, if you wish to run the model in DCS mode or Conventional Mode ONLY, then you can de-solder the two wires attached to the DCS/DCC switch and solder them together. Ensure you use a piece of heat shrink tubing to insulate the solder joint.

If you wish to run the model in DCC Mode then you can de-solder the wires from the switch and put a small piece of heat shrink tubing over the ends of both wires to insulate them.

Note: When the wires are jumped together you can ONLY run the model in Conventional Mode or DCS Mode. You will NOT be able to run the model in DCC mode.

Note: In order to load the any software or sound files into the PS3/2 board you MUST have the switch in DCS mode.

Installing The Proto-Couplers

- Install the proto-couplers (C) onto the existing locomotive trucks or coupler mount locations using the existing hardware. Be sure to route the coupler wire harness through the chassis floor as shown.
- The front truck Proto-Coupler connector attaches to the black & purple harness from the 40-Pin chassis harness.

Note: Use coupler insulator (CC) as required to prevent shorts from coupler solder connections to truck axle.

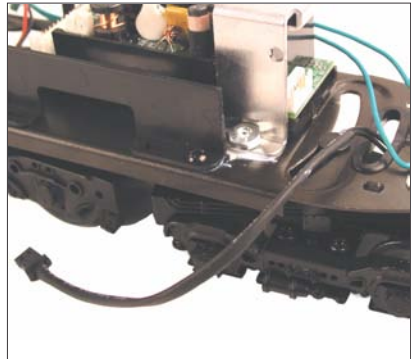

The Proto-Coupler installs in the same location as the original engine coupler.

Coupler Installation

A plastic insulator, item CC in the parts list of your Proto-Sound 3.0 Upgrade Kit, has been included with the rest of your Proto-Sound 3.0 Upgrade Kit parts.



Shown above is the coupler unassembled.

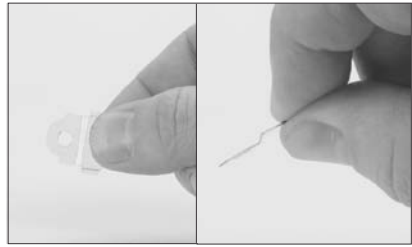

This insulator should be inserted between the coupler and the spring, washer and the coupler to the T-Bar and truck bolster. The insulator prevents the coupler wiring from contacting and short circuiting against the truck's axle. Failure to insert the insulator could permanently damage the coupler and Proto-Sound 3.0 board.

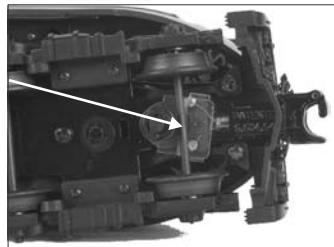

Shown here is the insulator attached to the truck and coupler. Ensure that the part of the insulator which protects the coupler's wires extends up not down when installed.

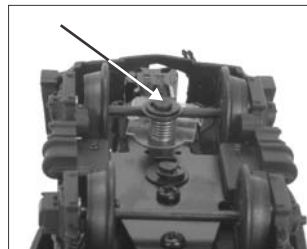

Proto-Sound 3.0 Chassis Wiring Diagram

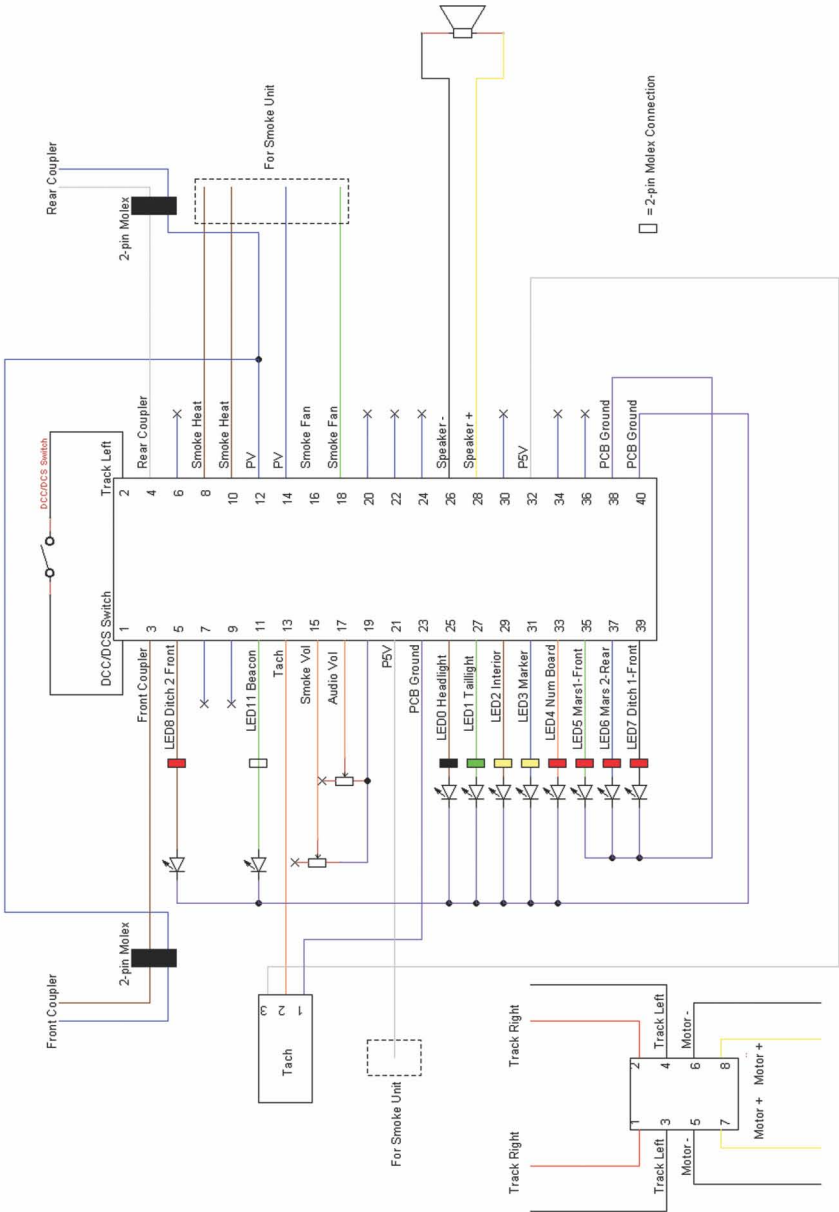

Proto-Sound 3.0 Board Connections

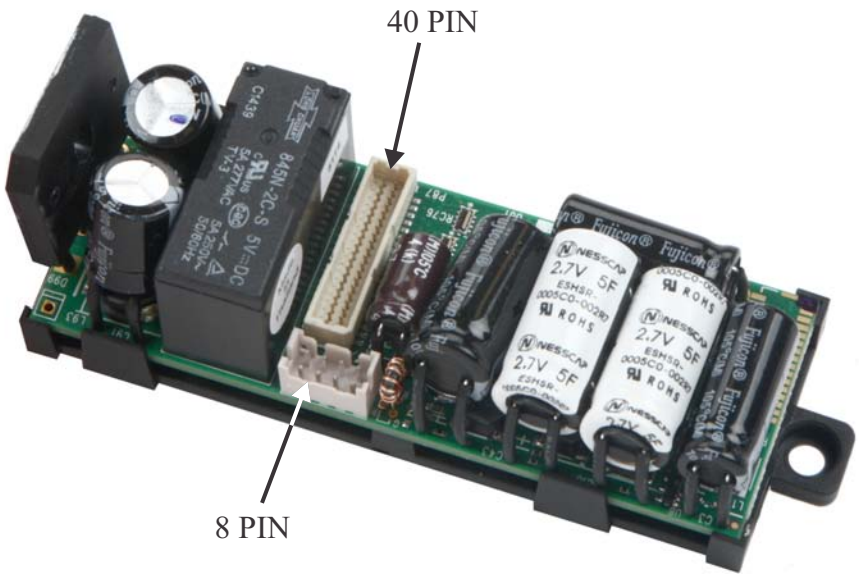

Installing the Chassis Harnesses, Speaker & Smoke Pot

- Attach 40 and 8-Pin Chassis Harnesses to the Proto-Sound 3.0 board (A) noting that each plug is polarized and has a different number of pins. Take care to insert the correct plug into the correct connector on the Proto-Sound 3.0 board. See previous pages for locations.

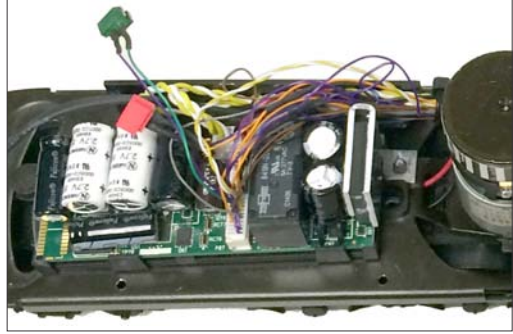

- Install the speaker (H) into the previous speaker mounting location (if applicable) using the existing hardware.

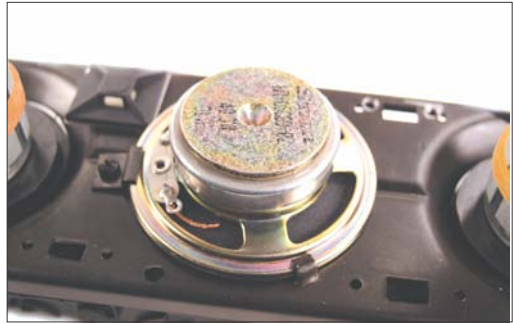

Use the existing speaker location (if applicable) to mount the new speaker. Many diesel engines will use the fuel tank to house the speaker. Use the same mounting hardware for the original speaker.

- Use the existing smoke Vol Pot in the 40-Pin Harness, or move wires to existing ON/OFF switch.

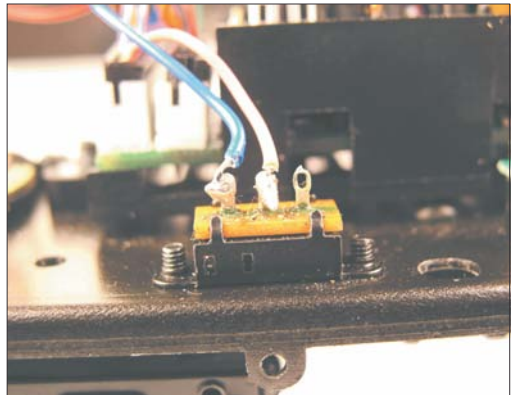

Wire the smoke unit switch wires into the existing smoke unit switch.

Soldering Speaker Connections

- Solder the yellow and white wires (R) to the speaker (H)
- Connect speaker plug to harness plug (white) with yellow & white wires coming from the 40-Pin Chassis Harness (S).

CAUTION: If either wire shorts to the speaker frame, the Proto-Sound 3.0 electronics will be damaged.

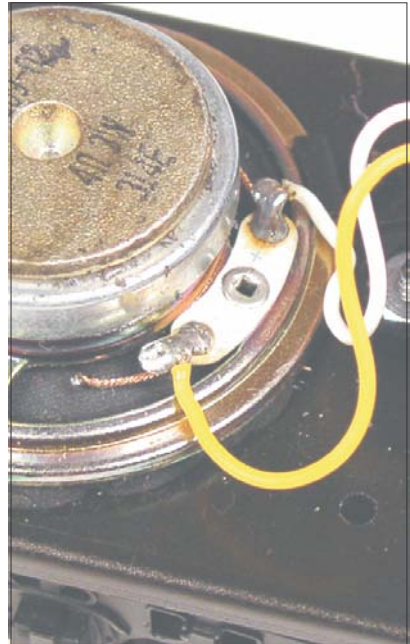

Installing The Volume Pot

- Mount the Vol Pot in the 40-Pin Harness or solder the wires from the 40-pin chassis harness to the existing volume pot. Red wire to the center terminal, blue to one outer terminal and gray to the other outer terminal.

Note: Volume pot not required for command operation. Solder gray and red wires together to get full volume in conventional mode and insulate the blue wire from chassis ground.



Solder the red, blue and gray volume pot wires to the volume pot. Red to the center terminal and blue and gray to the outside terminals.

Installing Tach Reader Bracket

- Based on the flywheel diameter (27 mm or 30 mm), install the tach reader mounting bracket (FF). The bracket is snapped into place on a Mabuchi or similar motor by spreading it open and sliding it under the flywheel. It may be necessary to use tape or epoxy glue to hold the bracket in position. Ensure the tach reader is attached to the motor whose truck has traction tires.

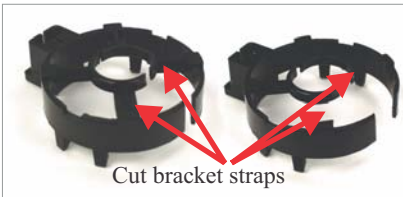

Some can motors are larger than others and will require that the tach reader bracket be modified in order to fit around the motor. Cut the bracket straps as shown.



Spread the Tach Reader bracket apart and slip between the flywheel and motor for engines equipped with Mabuchi or similar motors.



Push the bracket all the way onto the top of the motor. The small tabs extending down will "lock" onto motor casing.

Installing Tach Tape Onto Motor Flywheel

- Clean the flywheel with a cleaning solution and then install the tach tape (FFF) to the flywheel diameter and select proper tape). If the tape is wider than the flywheel, trim with a razor and straight edge before installing. Apply tape end with the largest white portion first, wrap the tape around the flywheel until it overlaps.



Wrap the tach tape around the flywheel by starting with white end first.

Mounting Tach Reader To Tach Reader Bracket

- Insert the tach reader into the tach reader bracket.
- The gap between the optical sensor and flywheel should be 0.5mm (0.022")-1.5mm (0.060"); 0.75mm (.030") is optimum.
- If the gap is too large, decrease the tach reader space between reader and flywheel as detailed below.
- Spark plug feeler gauges are useful to establish the proper gap.



When inserted into the tach reader bracket, the distance between the tach reader and the flywheel should be between the tach reader and the flywheel should be between .5mm & 1.5mm.

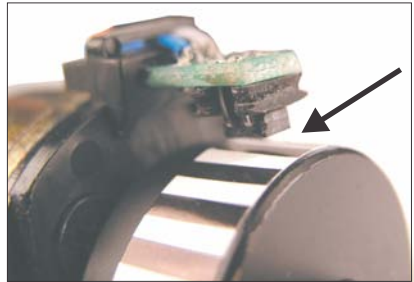

Check the distance between the flywheel and tach reader. If there is no gap, you need to use the bracket for a 30 mm flywheel.

Connecting Motor, Ground & Pickup Wires

- Solder the yellow and white wires from the 8-Pin Motor Harness to the motors. As noted on page 9, observe the wire color code of the previous electronics to ensure both motors turn in the same direction. If the engine starts out in the reverse direction, you will later need to reverse the yellow and white wires to the motor. This will not be tested until installation is complete.
- Connect the red wire from the 8-Pin Chassis Harness to the existing wires from the pick-up rollers.
- Connect the black wires from the 8-Pin Chassis Harness to chassis ground.

Connecting Lights (LEDs)

- Install the Ditch, Headlight, Marker, Mars, Overhead Blinking, Cab Interior, Number Board & Back-up lightbulbs into the proper engine & wire harness locations as seen in the diagram on page 16.
 - On RailKing diesel locomotives, the headlight and backup light are usually a screw or bayonet based bulb inserted into a bracket mounted to the chassis. This bulb must be replaced with headlight bulbs (D&G) in the kit in order to have constant voltage, directional lighting. Secure the bulbs in place with tape or hot glue. *Do NOT wire the existing bracket and bulb into the Proto-Sound 3.0 harness. It will damage the lighting circuit.*
1. Connect the Front Headlight (double LEDs) with Blue connector to the Blue connector with Brown and purple wires.
 2. Connect the Rear Back-up Light (double LEDs) with Green connector to the Green connector with green and purple wires.
 3. Connect the Front Marker Lights (double Green LEDs) with Yellow connector to the Yellow connector with Blue and Purple wires.
 4. Connect the Rear Marker Lights (double Red LEDs) with Yellow connector to the Yellow connector with Blue and Purple wires.
 5. Connect the Interior Lights (double LEDs) with Yellow connector to the Yellow connector with Brown and Purple wires.
 6. Connect the two Number Board Lights (double LEDs) with Red connector to the Red connector with Orange and purple wires. One set goes to the front and the other to the rear.
 7. Connect the Front Ditch 1 Light with Red connector to the Red connector with Black and Purple wires.
 8. Connect the Front Ditch 2 Light with Red connector to the Red connector with Brown and Purple wires.
 9. Connect the MARS 1 light with Red connector to the White connector with the Green and Purple wires.
 10. Connect the MARS 2 light with Red connector to the White connector with the Blue and Purple wires.
 11. Connect the overhead blinking lights (as needed) with the White connector to the White connector with Green and Purple wires.

Note: If only one LED is required for Front, Rear, or Interior cut off one set of wires and cover the ends of the wires with electrical tape.

Connecting The Proto-Sound 3.0 Harness To The Smoke Unit

- Soldering Gray and Green wires to the smoke unit fan motor. If the smoke unit motor terminals are hooked up backward, the impeller will spin in reverse and fail to pump out the smoke. When properly wired, most impellers should rotate clockwise.

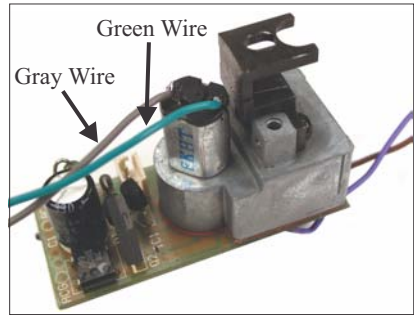

Follow the above wiring directions to the smoke unit motor:

- Cut through the traces on the top of the smoke unit board. **The heating elements MUST be isolated from the electronics on the board or the Proto-Sound 3.0 board will be permanently damaged.** Another alternative is to cut the printed circuit board such that the electrical components are no longer present since the Proto-Sound 3.0 hardware will be managing the smoke unit heating elements and motor - *see alternate cut line.*

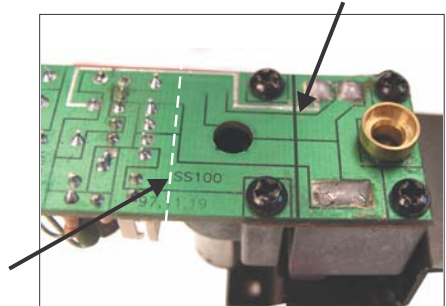

CRITICAL STEP

Use a razor saw to cut the bottom of the smoke unit circuit board, isolating the no longer required components on the left.

FAILURE TO CUT TRACE COMPLETELY WILL PERMANENTLY DAMAGE Proto-Sound 3.0 BOARD.

Make sure saw cut is free of debris that could form an electrical contact.

Connecting The Proto-Sound 3.0 Harness To The Smoke Unit *Cont'd*

- Solder the heating pads together at both sides on the top of the board by adding more solder. Then solder the Brown wire from the smoke unit wiring harness to one pad and the Purple to the other (the pads are interchangeable). Soldering to the trace for each end of the element is also acceptable.

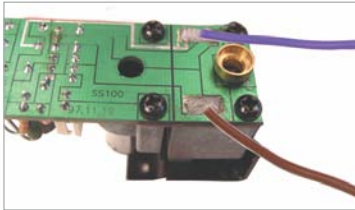

Connect the purple and brown wires to the solder pad locations as seen above.

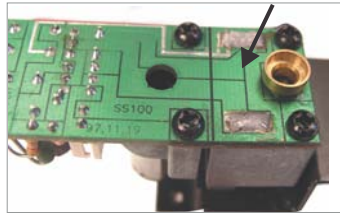

CRITICAL STEP

*Solder together the pads connecting the heating element to the circuit board as shown above. **Make sure the heating elements are in parallel.** You should measure 8 ohms across the pads. Failure to place the heating elements in parallel will permanently damage the Proto-Sound 3.0 board.*

Wire Management/Short Circuit Protection

- Route the wires around the motor and chassis such that the wires will not be pinched when the body is installed. Use pieces of wire management coil (Q) to hold various cables in place.

Note: The wires may need to be cut and spliced together to shorten the length of the wires. Use the shrink tubing (S) supplied in the kit for this purpose whenever necessary.



Testing The Proto-Sound 3.0 Upgrade Installation

- Place the engine chassis on a test section of a track.
- Apply 12 volts of power (in conventional mode) to the engine. If you have a Z4000 look at the current display. The engine should not draw more than 1.5 amps. If the engine draws more than 1.5 amps, shut down power to the engine immediately and check your wiring for any pinched or cut wires. Turn the smoke unit switch off and power up again in conventional mode. The engine without the smoke unit on should not draw more than 1.0 amp. Troubleshoot any problem in the smoke unit or wire harness accordingly.
- Check the smoke unit for operation. If no smoke is coming out or you can't feel the fan blowing air out, the gray/green wires connected to the fan motor may be reversed.
- Press the direction button and verify the locomotive moves in the forward direction. If the two motors in a twin-motored unit appear to be fighting each other, reverse the white and yellow motor wires on one motor. If the engine starts in reverse, reverse the yellow and white wires to both motors. If the engine does not move, the engine may be locked in neutral, see lock/unlock command on page 32.
- Press the whistle button and verify the horn test sound. The sound is not a normal horn but a test tone.
- Press the bell button and verify the bell test sound. The sound is not a normal bell but a test tone.
- Fire the coupler using the combination signal in conventional mode or the digital signal with the DCS remote.
- Press the direction button and verify the engine stops.
- Press the direction button again and verify the engine moves in reverse direction and that the headlight and back-up lights work properly.
- Install the body on the engine chassis being very careful not to pinch any wires in the process and repeat the tests above.

Loading The Proto-Sound 3.0 Sound File Into The Upgraded Engine

Before your upgraded locomotive will play locomotive sounds, the Proto-Sound 3.0 circuit board needs to be programmed with the appropriate Proto-Sound 3.0 File for your engine type. Programming can only be accomplished with the M.T.H. DCS Digital Command System and the free DCS Loader Program. The Loader Program and complete instructions for downloading/installing the Loader Program can be found on the Proto-Sound website (www.protosound2.com).

Note: It is important to remember that only the Proto-Sound 3.0 Files can be used to program your Proto-Sound 3.0 Upgrade circuit board.

Note: In order to load the any software or sound files into the PS3/2 board, you MUST have the switch in DCS mode.

Once you have the DCS equipment and have downloaded the DCS Loader Program, you will need to visit the MTH website and search for your locomotive model or one similar to it in order to find the Proto-Sound 3.0 files you will need to download. Each Proto-Sound 3.0 file has been optimized for its intended locomotive and takes into consideration lighting, the type of motor, the gear ratio and most importantly, the size of the drive wheels to govern the speed of the locomotive. Users trying to install a switcher locomotive (i.e.: SW-1500) Proto-Sound 3.0 File into a large mainline electric engine (ie: Taurus), for example, will find that the locomotive cannot run at the same scale speed as other engines and that the lighting may not be properly controlled. This is because the wheel sizes of the two different locomotives are drastically different from one another.

Follow the illustrations on the following pages to learn how to search for the locomotive you are upgrading and download the appropriate Proto-Sound 3.0 files. Once the Proto-Sound 3.0 files have been downloaded into the engine, it will be necessary to program the engine name using the DCS remote. Follow the DCS instructions for renaming a locomotive.

Note: If you are upgrading a non-M.T.H. Locomotive, pick a model in the search engine similar to the model you are upgrading. It is possible that the scale speeds and lighting may be slightly off for the reasons discussed above.

STEP 1:

The Proto-Sound 3.0 upgrade kit utilizes a Proto-Sound 3.0 Diesel/Electric board that uses Proto-Sound 3.0 sounds. To find a Proto-Sound 3.0 file, go to www.mthtrains.com and select “Service”. Then select “Proto-Sound Files” from the available options.



Select “Service”

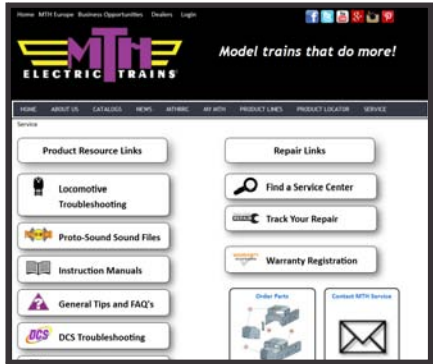

Click on “Proto-Sound Sound Files”

STEP 2:

Search using the general engine type, such as SD70.

Refine the search by selecting the Product Line, or the Road Name desired. (Note: You may have to use another road name or product line - RailKing vs. Premier - for the upgraded engine.) If you do not find a sound set with the appropriate product line or road name, select the best sound for the locomotive.



Search for the general engine type

Since most Diesel/Electric models use a standard wheel diameter and gear ratio, RailKing and Premier sound files can be used interchangeably without effecting the speed. (Note: Premier engines usually have more lighting options.)



Indicates Freight Yard Sounds



Indicates Passenger Station Sounds

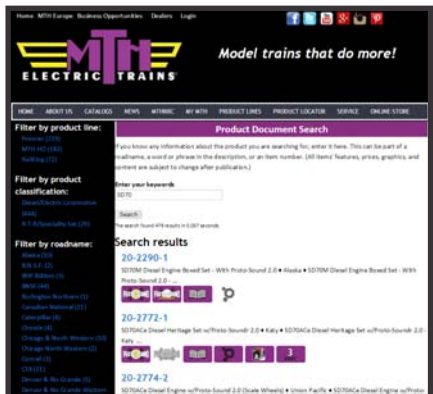

Refine your search results with these options

STEP 3:

Select the Proto-Sound 3.0 file from the results list. Right click and save the Proto-Sound 3.0 Consumer Package file in .zip format to your computer. Save it in the My MTH Files folder, located in C:/Programs/MTH DCS Loader/My MTH Files, so the files will be found easily.

Unzip the file one time to the same location to expose the Sound file (...F4x.MTH) and the Chain File (chain or code.zip). Use the appropriate icon on the loader to install the sound file and the FLASH icon on the loader to load the chain file into the engine.

Use the DCS Loader Program to load the sound file into your engine.

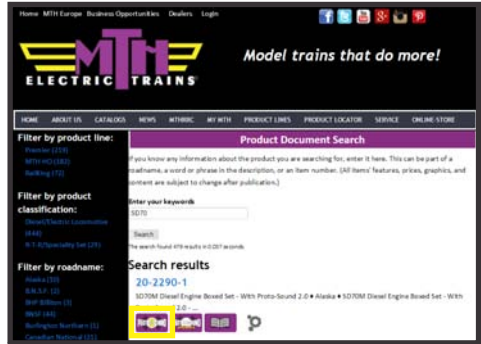

Click and save the .zip file to your computer

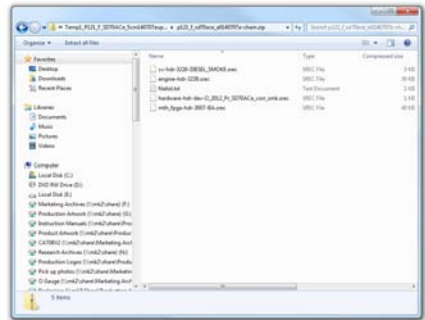
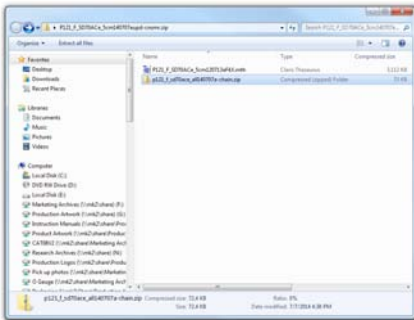

STEP 4:

Name the engine so the name appears on the DCS remote using the Edit Name DCS feature under Engine Setup. Add the engine to the DCS system. The engine will add, but no name will appear next to the engine address number. Use the edit name feature to add the engine name (limit 16 characters).

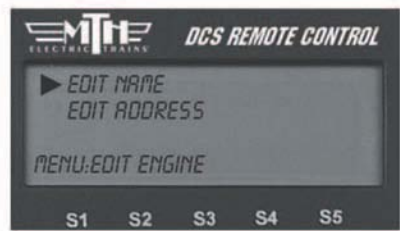

After adding the engine into the DCS system, name the engine on your DCS remote using the Edit Name feature

Conventional Proto-Sound 3.0 Operation

This manual contains the operating instructions for Proto-Sound 3.0 in conventional mode only. Instructions for accessing DCS command mode features accompany the DCS Remote Control System equipment. Instructions for DCC Command operation can be found on MTH's website.

Activating Features

Throttle: To increase or decrease track voltage, and therefore train speed, turn the throttle control knob. Turning clockwise will increase voltage and speed, while turning counterclockwise will decrease voltage and speed. The engine will maintain the speed you set after you release the throttle until you turn it again to change the voltage and speed.

Bell: To sound the bell, in an engine equipped with a bell firmly press and release the Bell button. To turn the bell off, press and release the Bell button again. The bell will continue to ring from the time you turn it on until you press and release the button again to turn it off.

Horn/Whistle: To sound the whistle, firmly press the Horn/Whistle button. The whistle will sound for as long as you continue to depress the button. It will stop when you release the button.

Direction: Your train is programmed to start in neutral. The train will always cycle neutral-forward-neutral-reverse with each press and release of the direction button. The engine is programmed to restart in neutral each time the track voltage is turned off for 25 seconds or more.

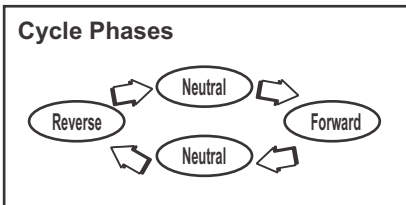

Manual Volume Control: To adjust the volume of all sounds made by this engine, turn the manual volume control clockwise to increase the volume and counter-clockwise to decrease the volume.

Activating Proto-Sound® 3.0 Conventional Mode Features

Proto-Sound® 3.0 features are activated by sequences of Bell and Horn/Whistle button pushes described below. Please read the full descriptions of each feature before using it. To use these buttons to activate features rather than to blow the horn or ring the bell, you should tap the buttons very quickly with a ½-second pause between button presses. You may need to practice your timing to make this work smoothly.

Timing Chart				
Press Horn Short & Firm	½ Sec. Pause	Press Bell Short & Firm	½ Sec. Pause	Press Bell Short & Firm
Total Time Lapse: 1 ½ Seconds				

Feature to Be Activated	Button Code:
PFA (Passenger/Freight Announcements)	1 Bell, 2 Horn/Whistles
Fire the Rear Coupler	1 Bell, 3 Horn/Whistles
Fire the Front Coupler	1 Bell, 4 Horn/Whistles
Speed Control On/Off	1 Horn/Whistle, 2 Bells (from Neutral only)
Lock into a Direction	1 Horn/Whistle, 3 Bells
Beacon Light (On/Off)	1 Horn/Whistle, 4 Bells
Reset to Factory Defaults	1 Horn/Whistle, 5 Bells (from Neutral only)

Passenger/Freight Announcements (PFA)

Your engine is equipped with a sound package of either passenger station announcements or freight yard sounds that you can play when you pull into a station or a yard. Each sequence described below will play as long as it is left on, randomly generating sounds, but be sure to allow approximately 30 seconds between the button pushes described below to allow the PFA sufficient time to run through each sequence.

- To cue the sound system to play the PFA, quickly but firmly tap the Bell button once followed by 2 quick taps of the Horn button while the engine is moving. Tap the buttons quickly but allow approximately 1/2 second between each press.
- Press the Direction button once to stop the engine. This will trigger the first sequence of PFA. The reverse unit is temporarily disabled so that the train will not move as you use the Direction button to trigger the sounds. Proto-Sound 3.0 has disabled operator control over the Horn and Bell buttons until the full PFA sequence is complete.
- After waiting about 30 seconds for that sequence to run, press the Direction button again to trigger the second sequence of PFA.
- After about 30 seconds, press the Direction button again to trigger the third PFA sequence.
- Again, after allowing about 30 seconds for that sequence to run, press the Direction button one more time to trigger the fourth and final PFA sequence. The PFA will continue and within a few seconds the bell will begin ringing, then the engine will begin moving at the current throttle setting, in the same direction it was traveling when you began the sequence. Once the bell turns off, the operator regains control of the transformer's bell and Horn buttons and can ring the bell or blow the Horn as usual.

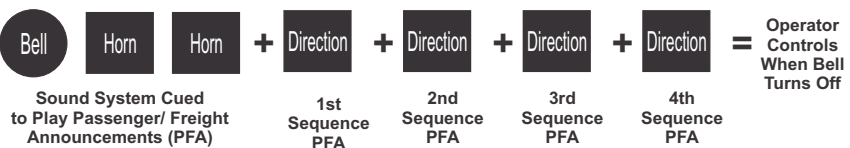

Tips on Using PFA

- You can terminate PFA at any time by turning off power to the track for 15 seconds.
- You do not have to be in Forward to use PFA. At the conclusion of the full sequence, the train will pull away from the station or yard in whatever direction you were going when you activated the feature.
- You can use PFA even if you are double-heading with another engine. If the second engine is not equipped with Proto-Sound® 3.0, you must remember not to leave the throttle at a high voltage level once you have stopped the engine to run the PFA. Otherwise, the engine without PFA will begin vibrating on the track as its motors strain to move the train, since they cannot be automatically disabled during the PFA cycle (or if an original Proto-Sound® engine, PFA are triggered differently and that engine's motor-disable feature will not be active when you run PFA in Proto-Sound® 3.0).
- PFA can be triggered from Neutral. It will operate the same as if triggered while in motion except that, at the conclusion of the PFA, the engine will depart in the next direction of travel, as opposed to the direction it was traveling before entering Neutral.

Proto-Coupler™ Operation

This locomotive is equipped with one or more coil-wound Proto-Couplers for remote uncoupling action. Because Proto-Couplers are controlled through the Proto-Sound® 3.0 microprocessor, they do not require an uncoupling track section or modification to your layout to function. You can fire a coupler from neutral or while in motion. Use the code shown below to fire the coupler(s).

Rear Coupler

To fire the rear coupler, quickly tap the Bell button once followed by three quick taps of the Horn button, allowing approximately ½ second to lapse between each quick button press. The sound of the liftbar and air line depletion will play, and the knuckle will be released.



Front Coupler

To fire the front coupler (if your engine has one), quickly tap the Bell button once followed by four quick taps of the Horn button, allowing approximately ½ second to lapse between each quick button press. The sound of the liftbar and air line depletion will play, and the knuckle will be released.



Speed Control

M.T.H. engines equipped with Proto-Sound® 3.0 have speed control capabilities that allow the engine to maintain a constant speed up and down grades and around curves, much like an automobile cruise control. You can add or drop cars on the run, and the engine will maintain the speed you set.

While the engine is programmed to start with the speed control feature activated, you can opt to turn it off. This means the engine's speed will fall as it labors up a hill and increase as it travels downward. It is also affected by the addition or releasing of cars while on the run. Because the engine will run more slowly at a given throttle voltage when speed control is on than when it is off, you should adjust the throttle to a lower power level for operation with speed control off to avoid high-speed derailments. When speed control is off, the volume will drop to allow for better low voltage operation.

To turn speed control on and off, put the engine in neutral, then quickly tap the transformer's Horn button one time then quickly tap the Bell button two times, allowing approximately ½ second to lapse between each quick button press. Two horn blasts will indicate that the engine has made the change. Repeat the 1 horn, 2 bells code to return it to the other condition. You will want to do this during the initial neutral upon start-up if you ever couple this engine to another engine that is not equipped with speed control to avoid damaging the motors in either engine. Each time you shut down the engine completely, it will automatically turn speed control on.



Locking Locomotive Into A Direction

You can lock your engine into a direction (forward, neutral, or reverse) so that it will not change directions. To do this, put the engine into the direction you want (or into neutral to lock it into neutral), run it at a very slow crawl (as slowly as it will move without halting), and quickly but firmly tap the Horn button once followed by three quick taps of the Bell button, allowing approximately ½ second to lapse between each quick button press. Two horn blasts will indicate that the engine has made the change. The engine will not change direction (including going into neutral) until you repeat the 1 horn, 3 bells code to return the engine to its normal condition, even if the engine is kept without power for extended periods of time.



Reset to Factory Default

To override the settings you currently have assigned to the engine and reset it to its factory defaults, while in Neutral tap the Horn button quickly once, followed by five quick taps of the Bell button, allowing approximately ½ second to lapse between each quick button press. Two horn blasts will indicate that the engine has made the change.



Automatic Sound Effects

Certain Proto-Sound® 3.0 sound effects automatically play in programmed conventional mode conditions:

- Squealing Brakes play any time the engine's speed decreases rapidly.
- Cab Chatter plays at random intervals when the engine idles in neutral.
- Engine Start-up and Shut-down sounds play when the engine is initially powered on or is powered off for five seconds or more.

Command Operation

- DCS - MTH Proprietary Digital Command System
- DCC - Digital Command Control

To get the DCS and DCC instructions, download the instruction manual from the Proto-Sound 3.0 engine files used.

Note: The DCS/DCC switch must be in the proper position. The DCS position provides continuity through the switch.

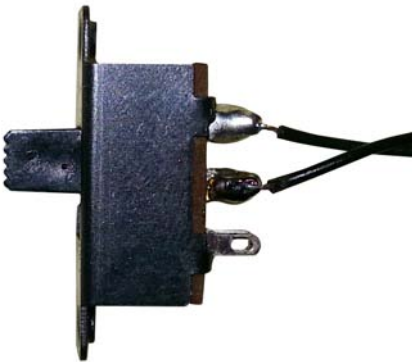

Switch is set to DCS mode.

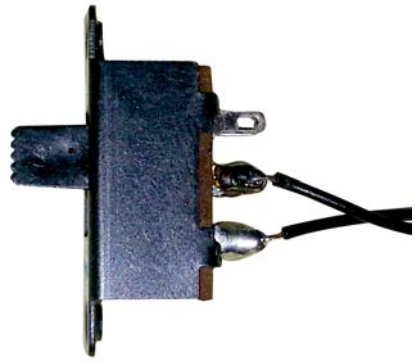

Switch is set to DCC mode.

Troubleshooting Proto-Sound® 3.0 Problems

Although Proto-Sound 3.0 has been designed and engineered for ease of use, you may have some questions during initial operation. The following table should answer most questions. If your problem cannot be resolved with this table, contact M.T.H. for assistance (www.mthtrains.com, e-mail: parts@mthrailking.com, Fax: 410-423-0009, Phone: 410-381-2580, Mail: 7020 Columbia Gateway Drive, Columbia MD 21046-1532).

Starting Up	Remedy
When I first turn the power on, the engine will not begin to run. I have to turn the throttle off and then on again to get the engine to operate.	This is normal behavior. To prevent accidental high-speed start-ups, Proto-Sound 3.0 is programmed to start up in neutral anytime track power has been turned off for several seconds. See the "Basic Operation" section for more details.
Whistle/Horn	Remedy
When I press the whistle/horn button, the bell comes on instead.	Reverse the transformer leads.
I can't get the horn to blow when I press the whistle button.	You may be pressing the button too quickly. Try pressing the whistle/horn button more slowly, taking approximately one full second to fully depress the button.
Bell	Remedy
When I press the whistle button, the bell sounds.	Reverse the transformer leads.
I can't get the bell to ring when I press the bell button.	You may be pressing the button too quickly. Try pressing the bell button more slowly, taking approximately one full second to fully depress the button.
The bell won't work on a separate bell button.	Check the wiring of the separate button.
Coupler	Remedy
When I try to fire the coupler, FYS starts.	You are waiting too long between whistle button presses.
The Proto-Coupler won't let the engine uncouple on the fly.	Try lubricating the coupler knuckle with a dry graphite lubricant. Do NOT use oil.
The coupler does not fire or stay coupled.	The coupler needs to be cleaned. Wipe with denatured alcohol (not rubbing alcohol) and let dry.

Cab Chatter	Remedy
Sometimes the Cab Chatter sounds don't play.	Cab Chatter plays only in neutral at random intervals.
Lock-out	Remedy
I can't get the engine to run after I power up the transformer. It sits still with the engine sounds running.	The engine is locked into the neutral position. Follow the procedure in the "Lock into a Direction" section.
The engine won't lock into forward, neutral, or reverse.	Engine speed must be below 10 scale mph (approx. 10 volts or less in conventional mode).
Volume	Remedy
The sounds seem distorted, especially when the whistle or bell is activated.	Proto-Sound 3.0 volume is set too high. Turn the volume control knob on the bottom of the chassis counter-clockwise to reduce the volume.
Battery	Remedy
The engine will not leave the initial neutral setting.	Check to be sure the battery is installed and fully charged. See the "Self-Charging Battery Back-Up" section.
I get no sounds when the engine shifts between directions.	The battery may be dead or need to be charged. See the "Self-Charging Battery Back-Up" section.
After I turn off my transformer, my engine continues to make sounds before quitting.	Proto-Sound 3.0 is designed to continue to sound for a few seconds after power to the track has been shut off.
FYS	Remedy
The FYS sounds occasionally repeat themselves.	Proto-Sound 3.0 has a built-in random number generator that randomly selects each sound clip to play. Because there are a limited number of sound clips available in each FYS sequence, it is probable that some of these sound clips will be repeated from time to time.

FYS	Remedy
Once in FYS, the engine doesn't go into reverse.	So that FYS effects can be as realistic as possible, Proto-Sound 3.0 disables the reversing unit whenever FYS is enabled. This way the engine remains still at its stop as the operator cycles through the FYS sequences.
When the FYS enters its last sequence the bell automatically comes on.	FYS is programmed to start ringing the bell at that point. After approximately 12 rings of the bell, it will automatically turn off.
When FYS is enabled, pressing the whistle and bell buttons has no effect.	Because FYS must control various effects in each sequence, Proto-Sound 3.0 takes control of these sound effects until you exit FYS.
I push the direction button but the next sound clip in the sequence does not play or the engine does not come out of FYS after fourth press of the direction button.	Each FYS clip must play for approx. 30 seconds before FYS will advance to the next step in the FYS cycle. Wait at least 30 seconds in each FYS sound clip before pressing the direction button.

Service & Warranty Information

How to Get Service Under the Terms of the Limited Warranty

When you suspect an item is defective, please check the operator's manual for standard operation and trouble-shooting techniques that may correct the problem. Additional information may be found on the M.T.H. Website. Should you still require service, follow the instructions below to obtain warranty service.

First, e-mail, write, call or fax the M.T.H. Authorized Proto-Sound 2.0 Conversion Center that installed the kit to obtain Repair Authorization. You can find the list of conversion centers on the M.T.H. Website, www.mth-railking.com. The center that installed the kit will provide service during the warranty period. Should the warranty no longer apply, you may choose either an ASC or NASC retailer to service your M.T.H. Product. A reasonable service fee will be charged.

CAUTION: Make sure the product is packed in its original factory packaging including its foam and plastic wrapping material to prevent damage to the merchandise. There is no need to return the entire set if only one of the components is in need of repair unless otherwise instructed by the Service Center. *The shipment must be prepaid and we recommend that it be insured. A cover letter including your name, address, daytime phone number, e-mail address (if available), Return Authorization number (if required by the service center, a copy of your sales receipt and a full description of the problem must be included to facilitate the repairs. Please include the description regardless of whether you discussed the problem with a service technician when contacting the Service Center for your Return Authorization.*

Please make sure you have followed the instructions carefully before returning any merchandise for service. Authorized M.T.H. Service Centers are independently owned and operated and are not agents or representatives of M.T.H. Electric Trains. M.T.H. assumes no responsibility, financial or otherwise, for material left in their possession, or work done, by privately owned M.T.H. Authorized Service Centers.

If you installed the PS-3 Upgrade Kit yourself, there is no warranty. Contact M.T.H. for replacement parts. Any required parts, plus shipping and handling fees will be charged. If you need assistance at any time email MTH Service at service@mth-railking.com, or call 410-381-2580.

Limited 90-Day Warranty

This product, when installed by an Authorized M.T.H. Proto-Sound 2.0 Conversion Center, is covered by this warranty. See our website at www.protosound2.com or call 410-381-2580 to identify an Authorized M.T.H. Proto-Sound 2.0 Conversion Center near you.

M.T.H. Proto-Sound 3.0 Upgrade Kits are warranted for 90 Days from the date of installation by an Authorized M.T.H. Proto-Sound 2.0 Conversion Center against defects in material or workmanship. We will repair or replace (at our option) the defective part without charge for the parts or labor, if the item is returned to the M.T.H. Authorized Proto-Sound 2.0 Conversion Center who installed the kit within 90 Days of the installation. This warranty does not cover damages caused by improper care, handling, or use. Transportation costs incurred by the customer are not covered under this warranty. This warranty does not cover any installation charges incurred from installing the conversion kit.

Items sent for repair must be accompanied by a return authorization number, a description of the problem, and a copy of the original sales receipt from an Authorized M.T.H. Proto-Sound 2.0 Conversion Center, which gives the date of purchase and installation of the kit. If you are sending this product to an Authorized Proto-Sound 2.0 Conversion Center, contact that Center for their return authorization. This warranty gives you specific legal rights, and you may have other rights that vary from state to state. Specific questions regarding the warranty may be forwarded to M.T.H. directly.

Service Department
M.T.H. Electric Trains
7020 Columbia Gateway Drive
Columbia, MD 21046-1532