

MTH Signal to Lionel ITAD

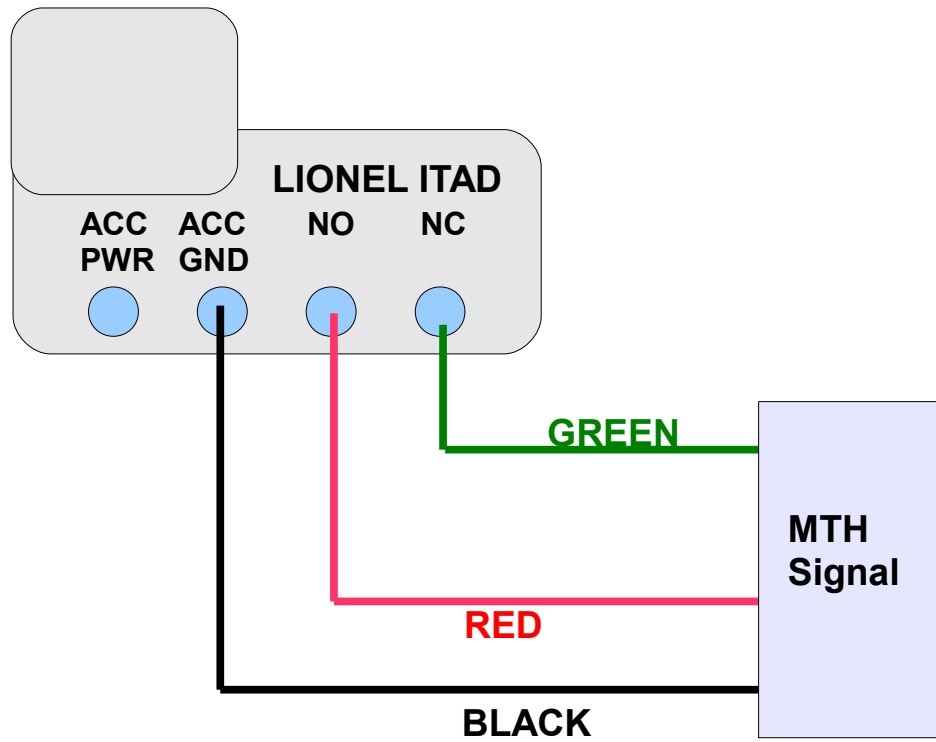

Multiple MTH Signals to Lionel ITAD

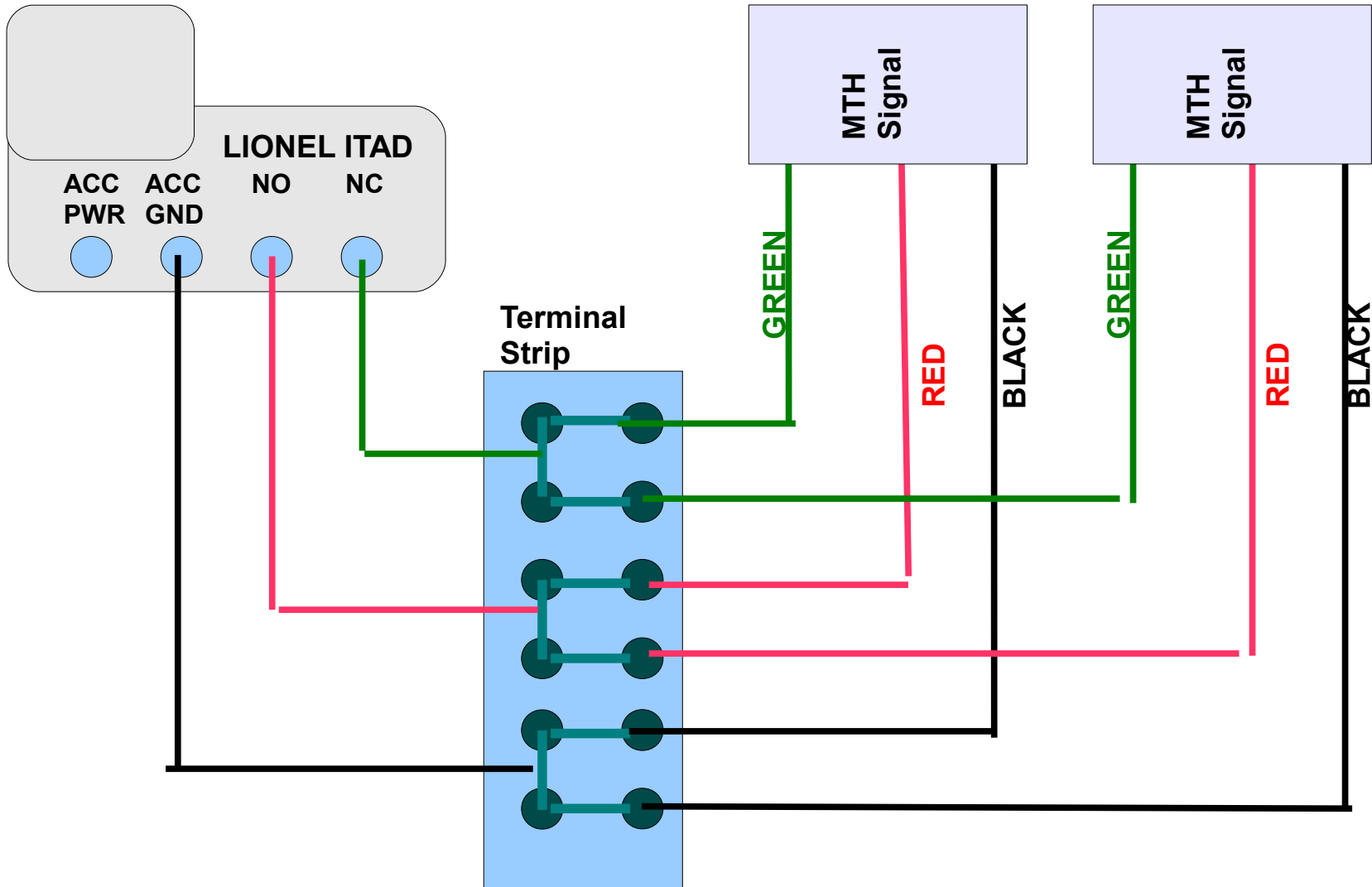

Lionel Signal to Lionel ITAD

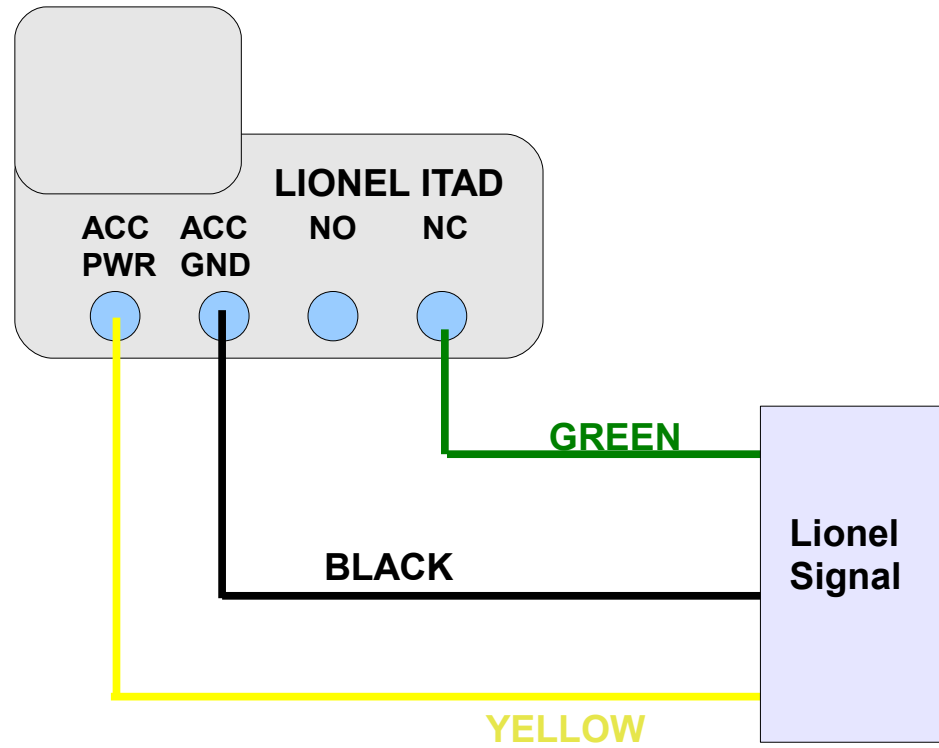

Multiple Lionel Signals to Lionel ITAD

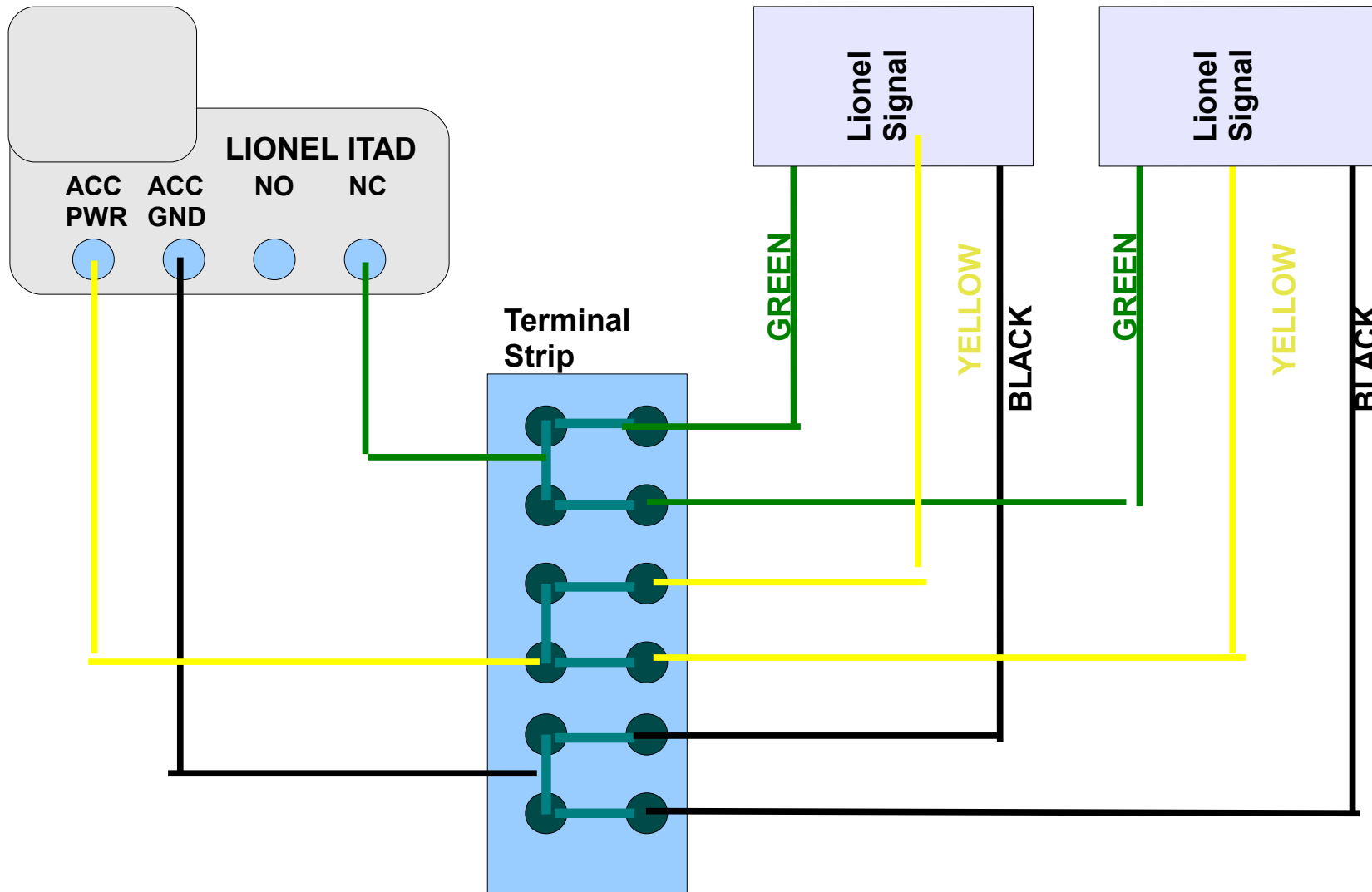

Rule of thumb – it is possible to connect multiple signals to one ITAD but not multiple ITADS to one signal

Lionel and MTH Signals to Lionel ITAD

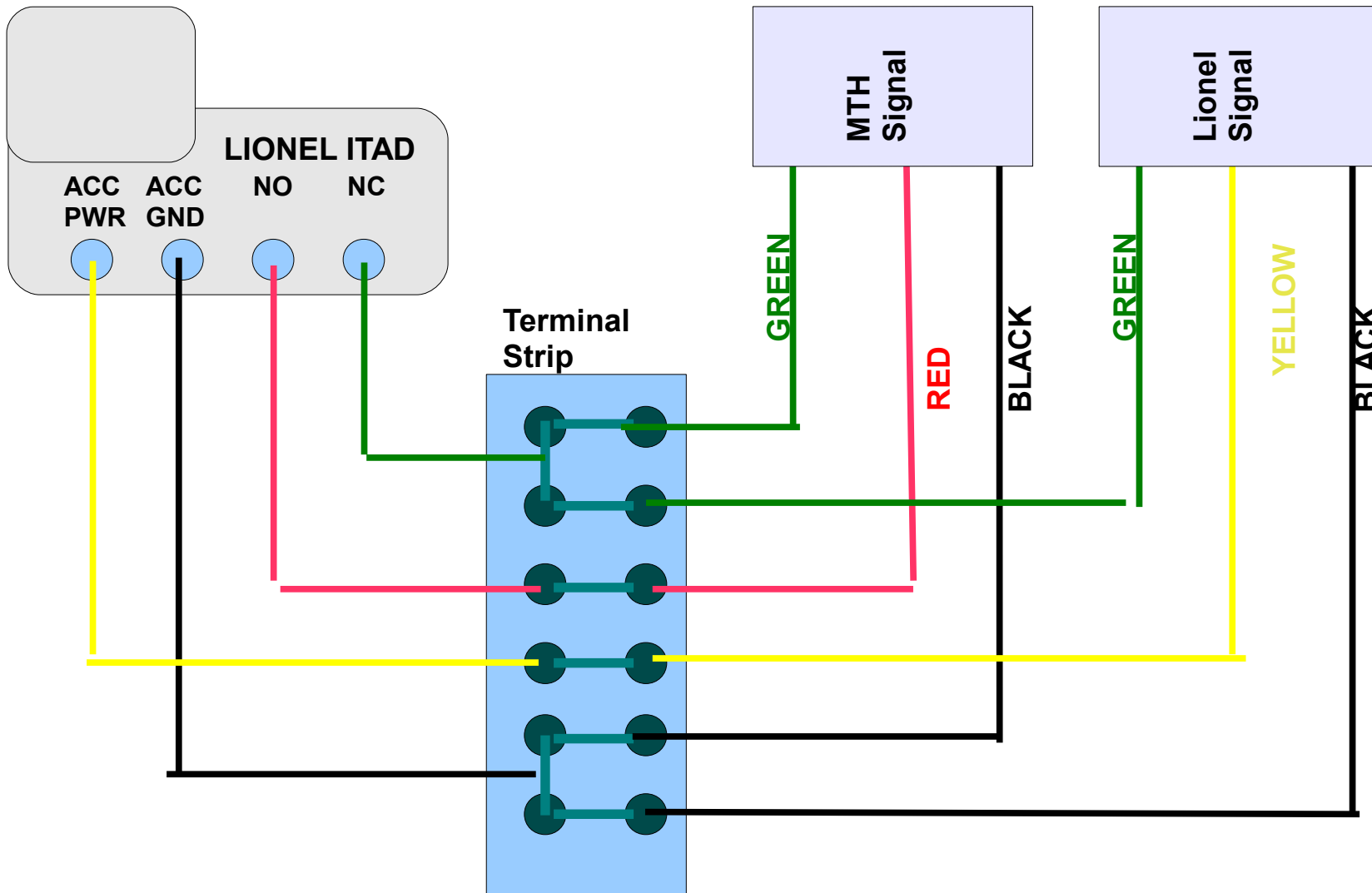

Rule of thumb – it is possible to connect multiple signals to one ITAD but not multiple ITADS to one signal

Lionel Signal to DZ 1075

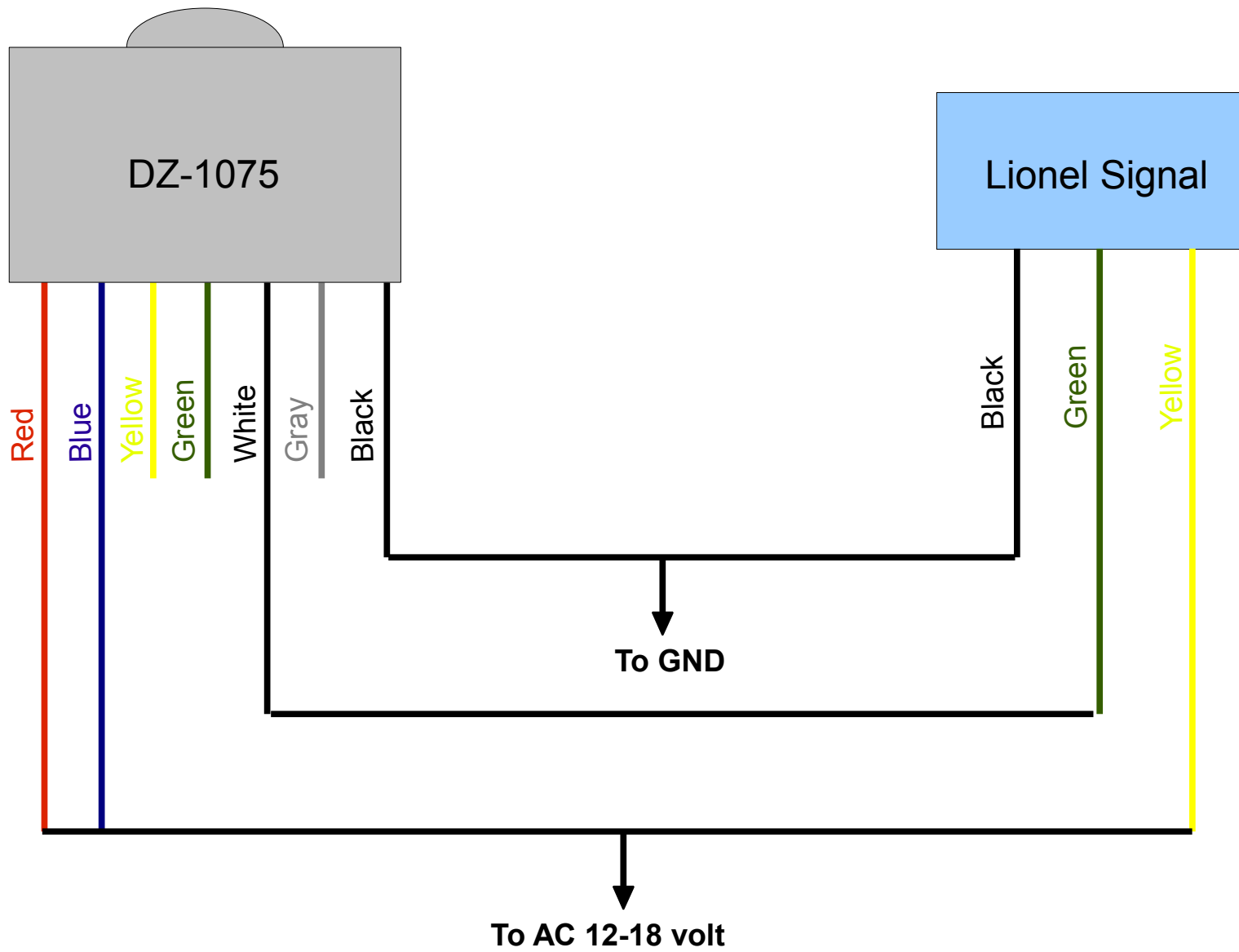

MTH Signal to DZ 1075

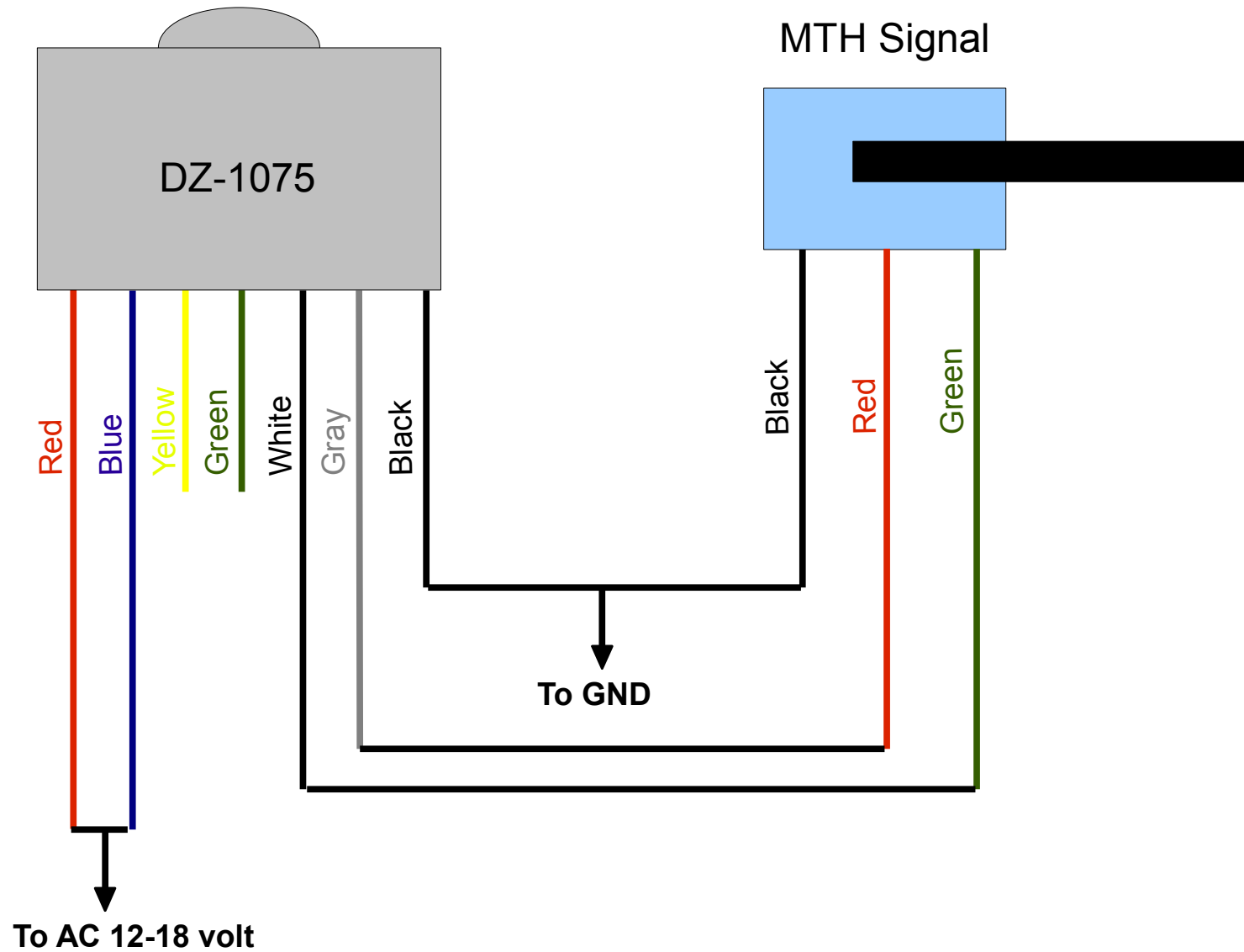

DZ 1060 Signal to DZ 1075

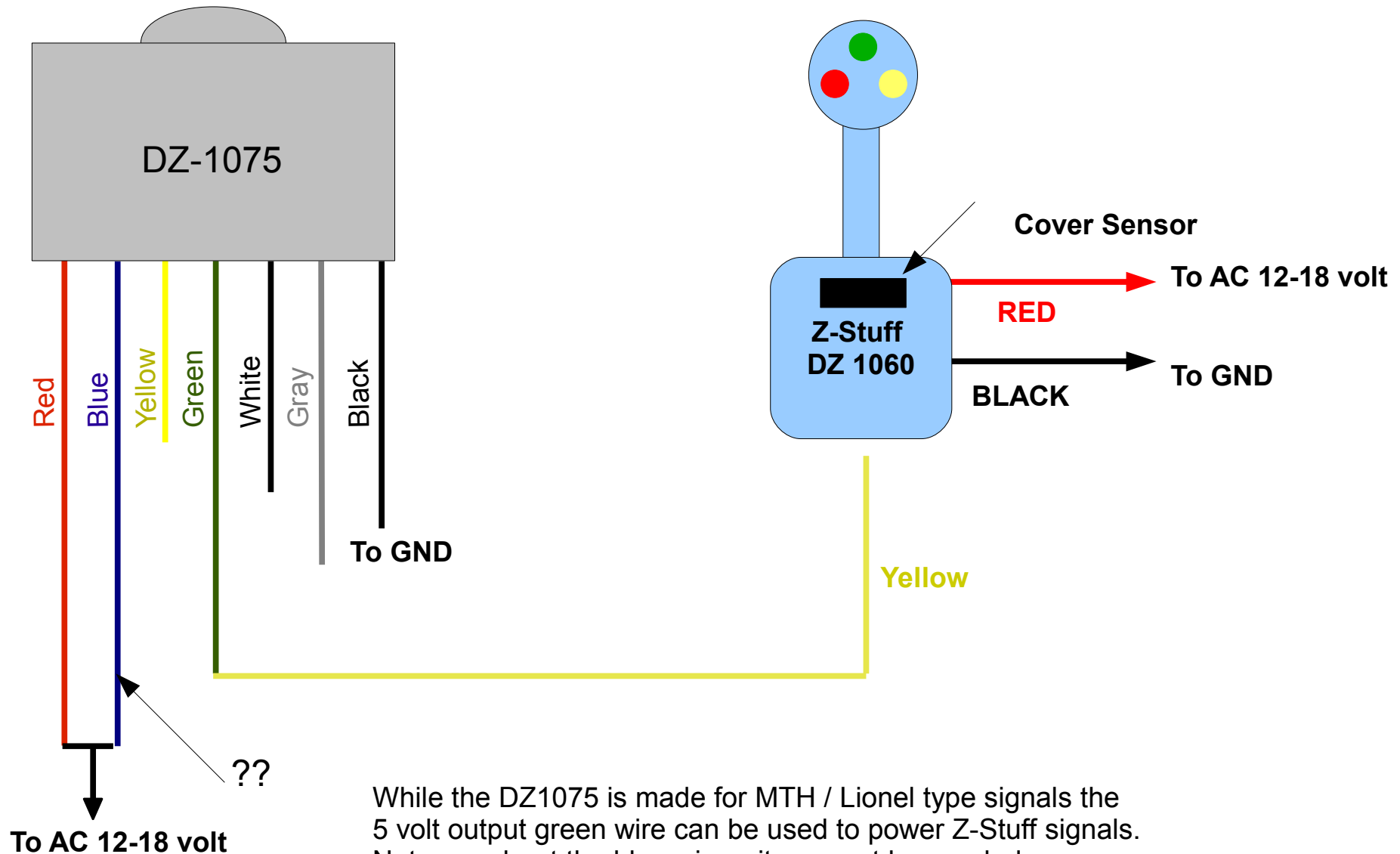

While the DZ1075 is made for MTH / Lionel type signals the 5 volt output green wire can be used to power Z-Stuff signals. Not sure about the blue wire – it may not be needed.

Z-Stuff Standalone DZ 1060

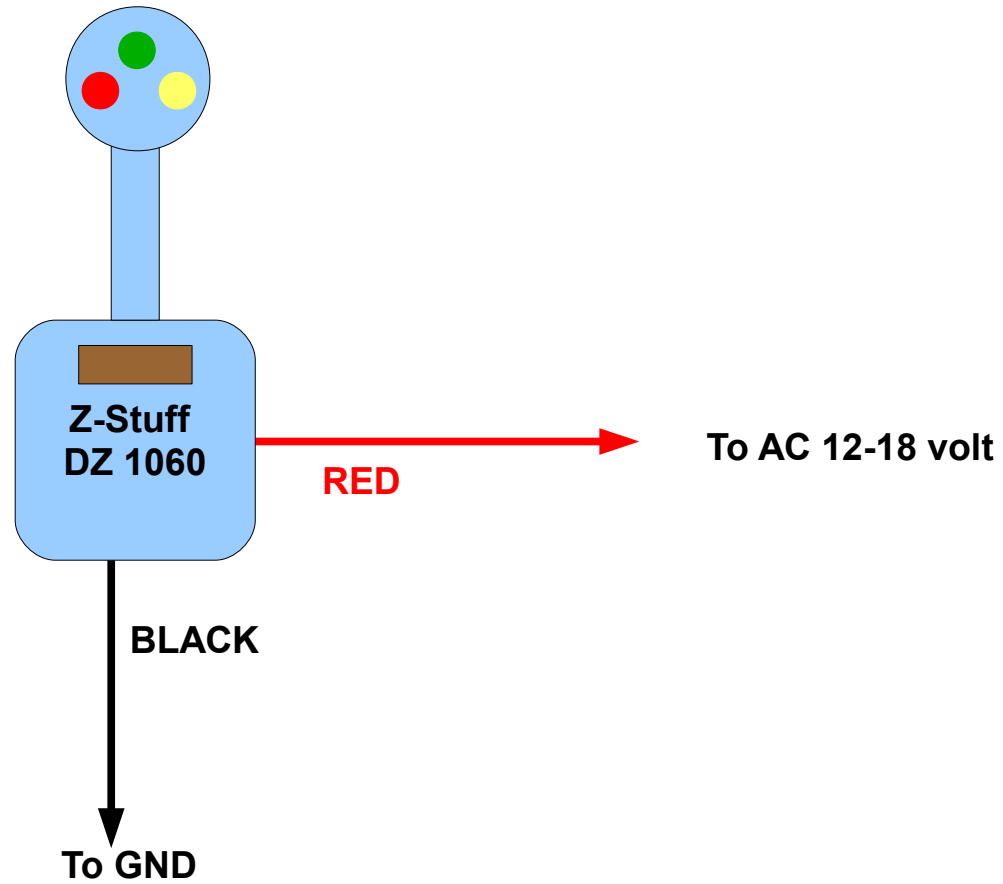

Z-Stuff DZ 1060 Signal Connected to DZ 1070 Detector

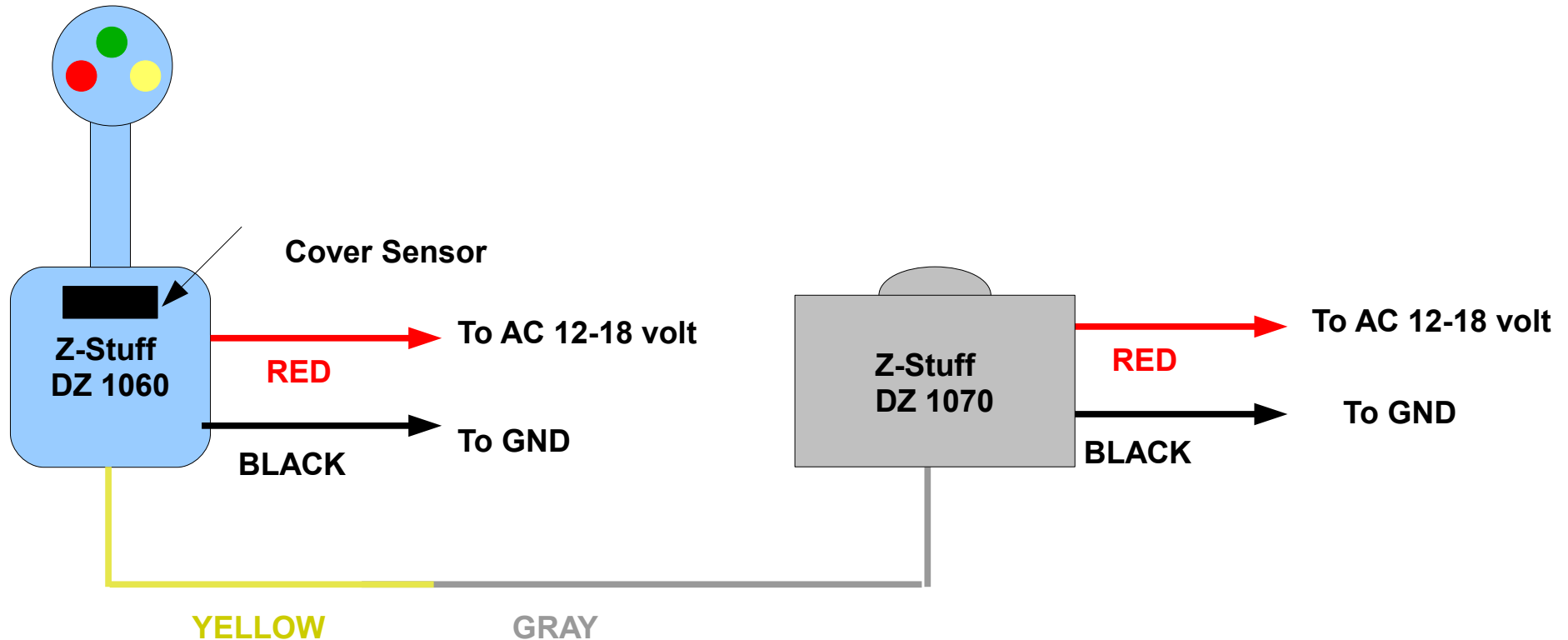

Allows signal to be remotely controlled by the 1070 sensor

Note: the DZ-1070 sensor is wired specifically for Z-Stuff signals. The DZ-1075 sensor must be employed when connecting MTH or Lionel signals.

Z-Stuff DZ 1060 Signal to Signal

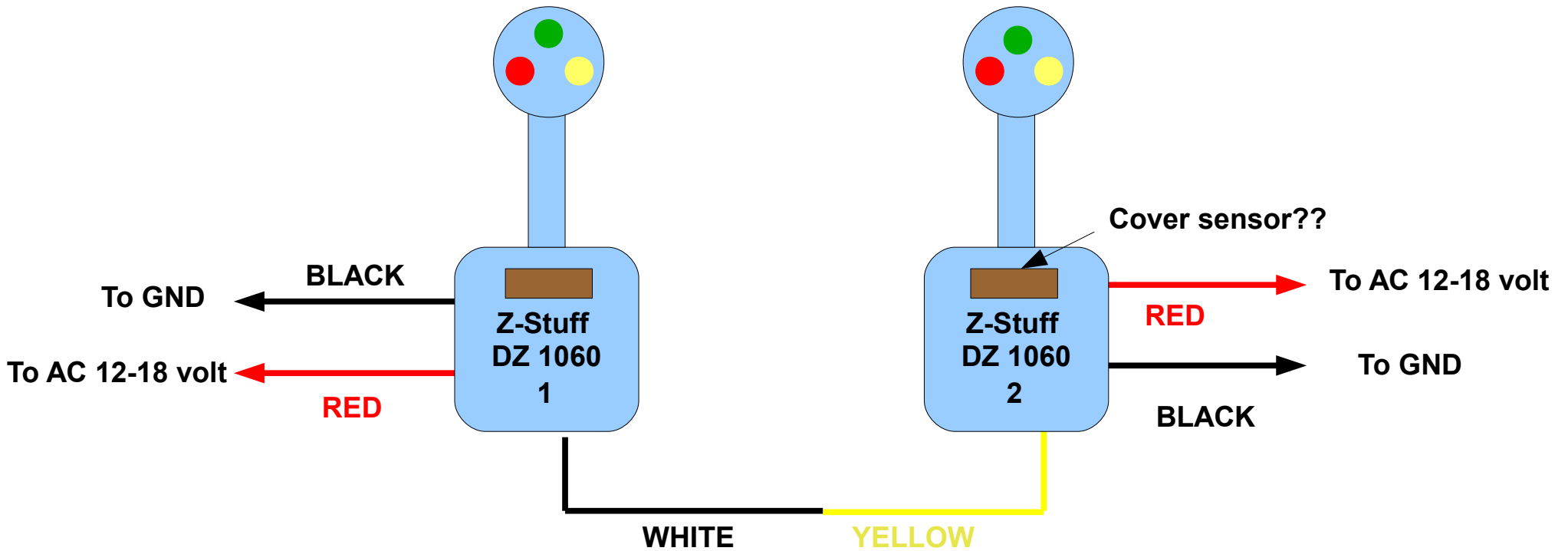

Signal 2 will stay yellow until Signal 1 turns red

Atlas O 21st Century Signals

For those who do not want to use light sensors on top of the train board Atlas O in combination with Custom Signals makes a complete set of signals and crossing gates which make use of track power along with isolated sections of track wired to sensor boards that can be mounted underneath the train table.

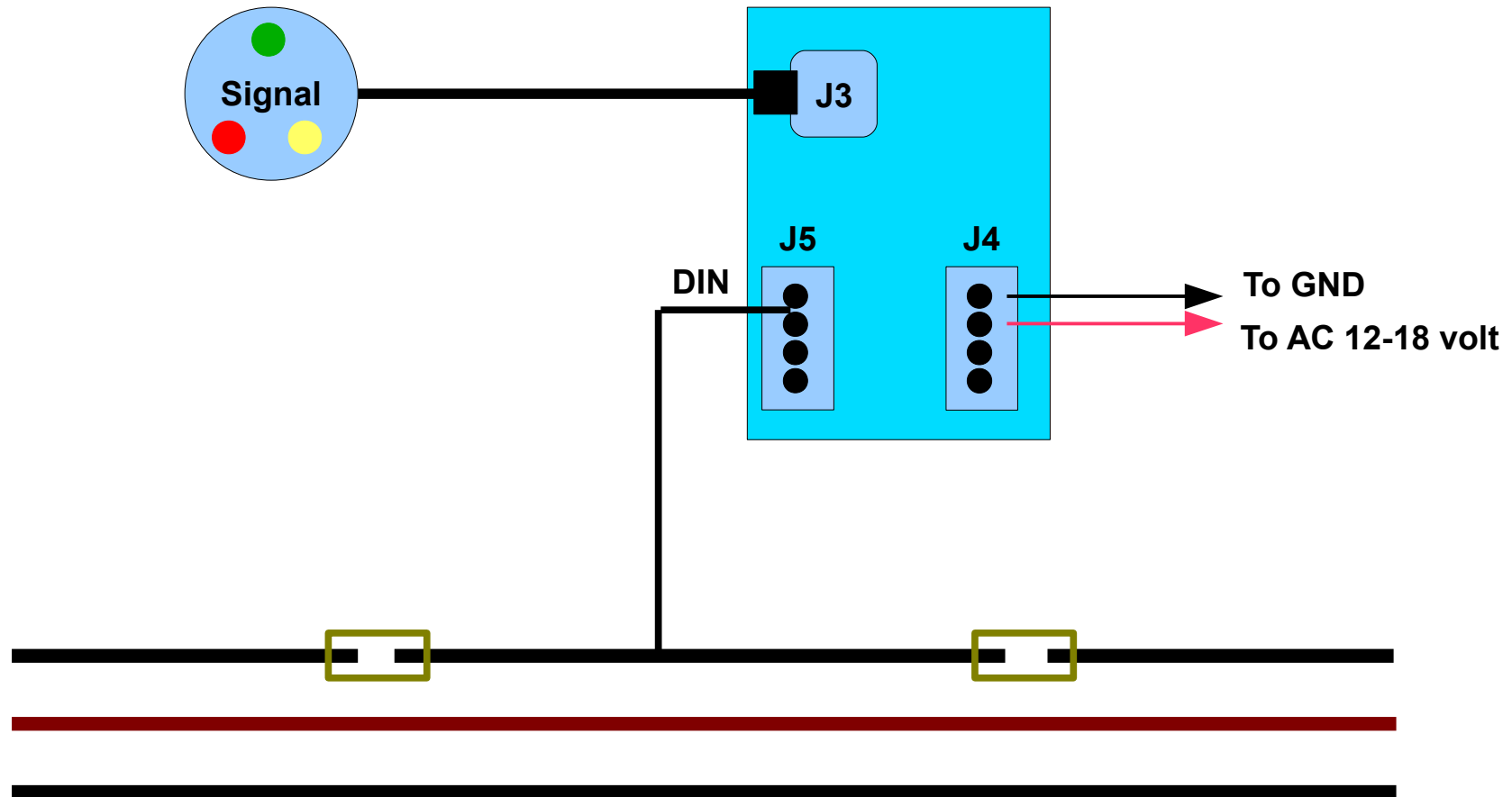

With power connected by this method the signal lights go through a timed sequence

Atlas O 21st Century Signal to Signal

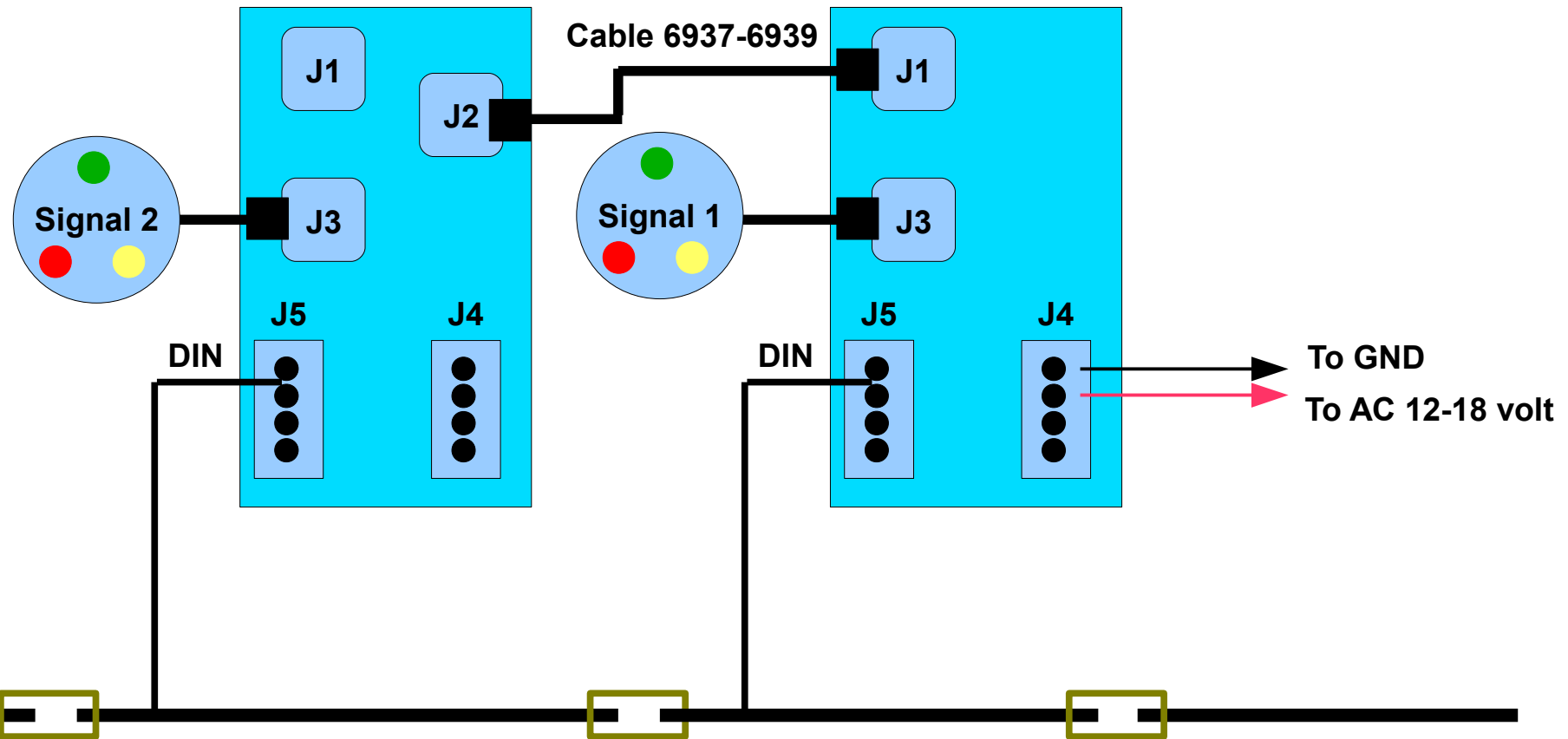

The timing mechanism controlling the lights is now disengaged and the track controls the signals.