

# Ross Double Crossover Wiring for Non-Derail and Power Diamond Rails

## Turnout Toggle Switches – Control Board

Atlas O is 1-15  
Ross is 16-31

All toggle switches now have ground connected to center post.  
Atlas O and ross switch machines now have power connected to center post

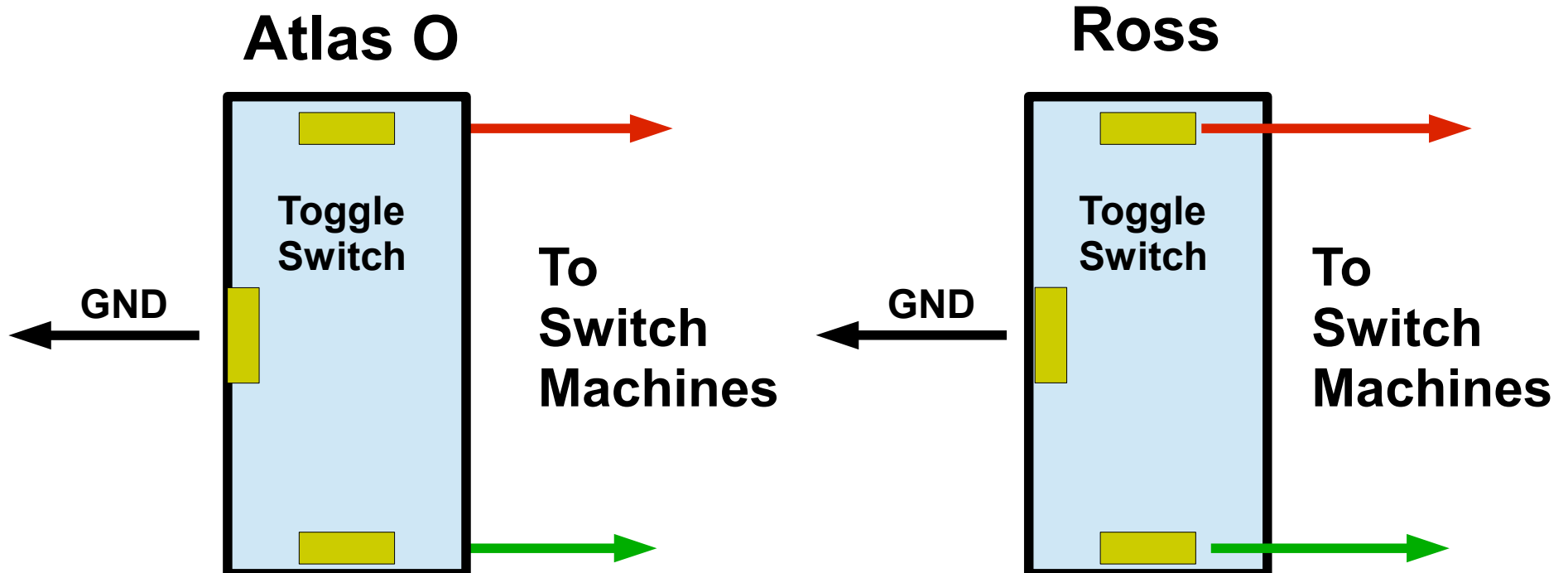

# Connecting Turnouts

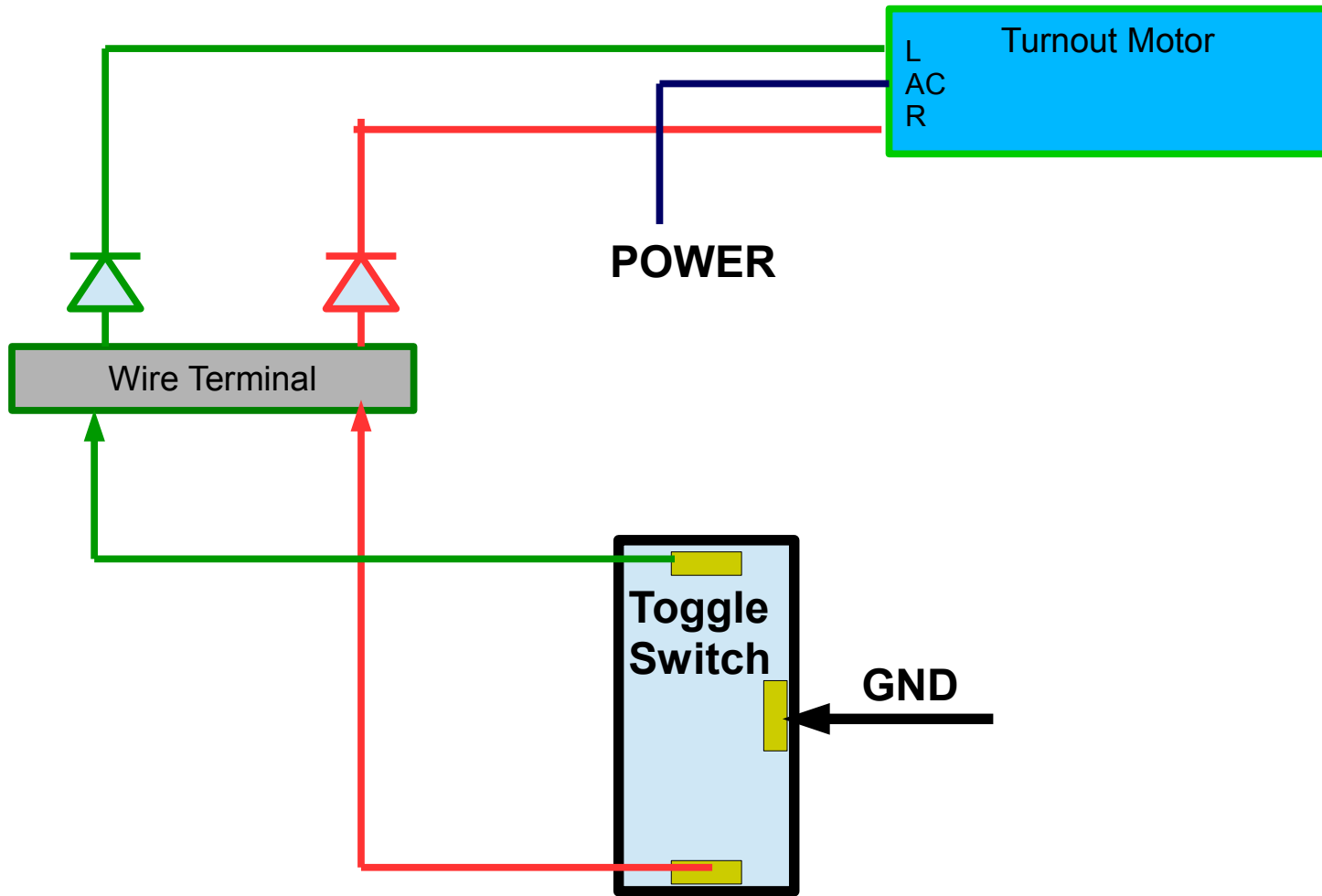

# Ross Double Crossover Wiring for Non-Derail and Power Diamond Rails

From inner rail of isolated track to “L” terminal of opposite switch machine

## Non-Derail

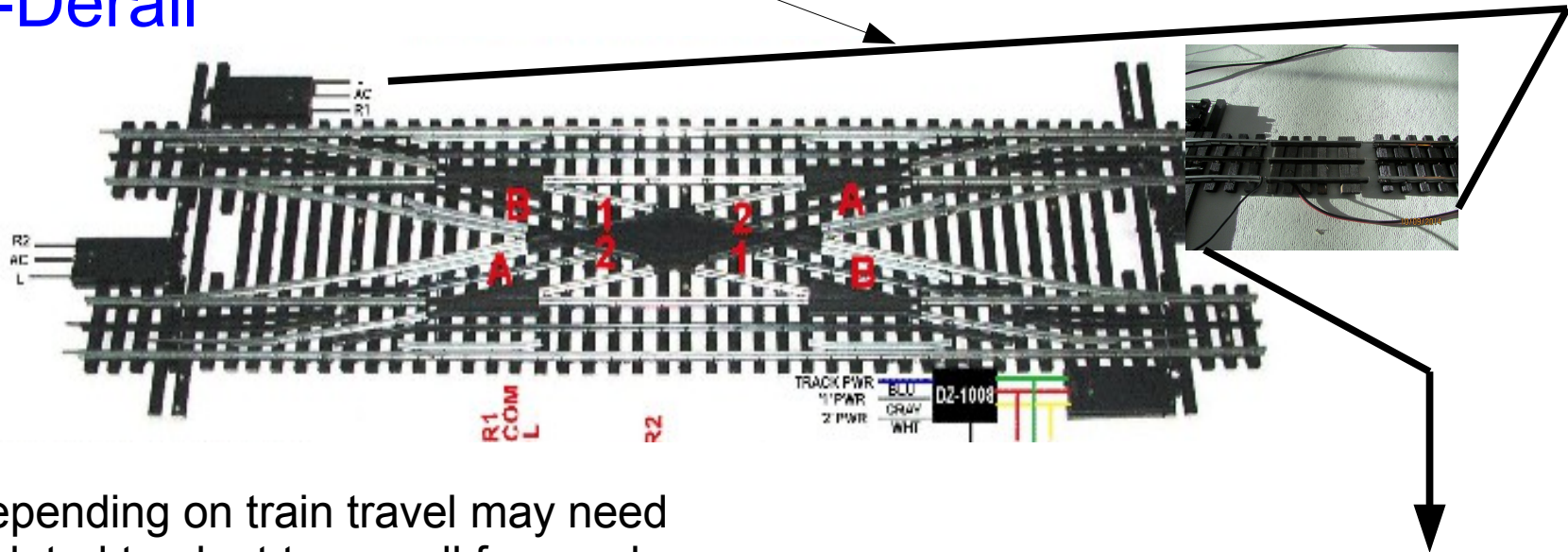

Depending on train travel may need isolated track at two or all four ends

To switch common ground

Wiring non-derail is very easy. A track with the inner common rail isolated from track common (rail is isolated on both ends) is connected in front of the turnout. A wire is connected from the isolated rail to the “L” through terminal of the DZ 1000 switch machine for the turnout on the opposite end. A second wire is connected from the inner rail of the crossover to common ground for the switch controllers (see next page)

# Ross Double Crossover Wiring for Non-Derail and Power Diamond Rails

## Non-Derail

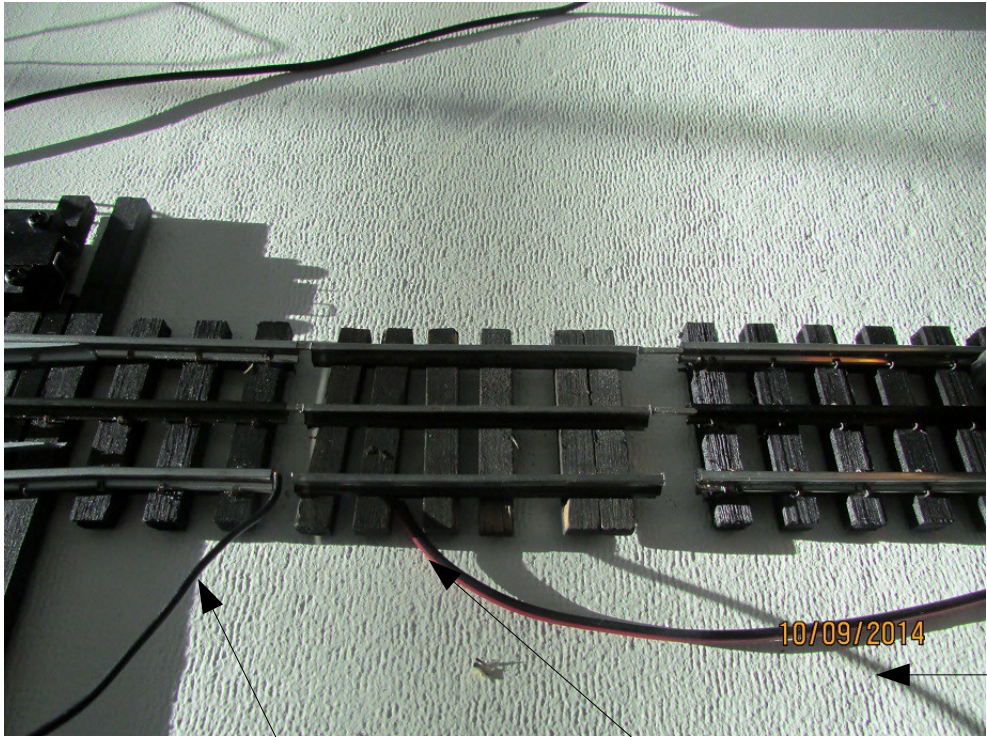

Wire to common ground

Wire to Switch machine

This is a shadow

# Ross Double Crossover Wiring for Non-Derail and Power Diamond Rails

## Non-Derail

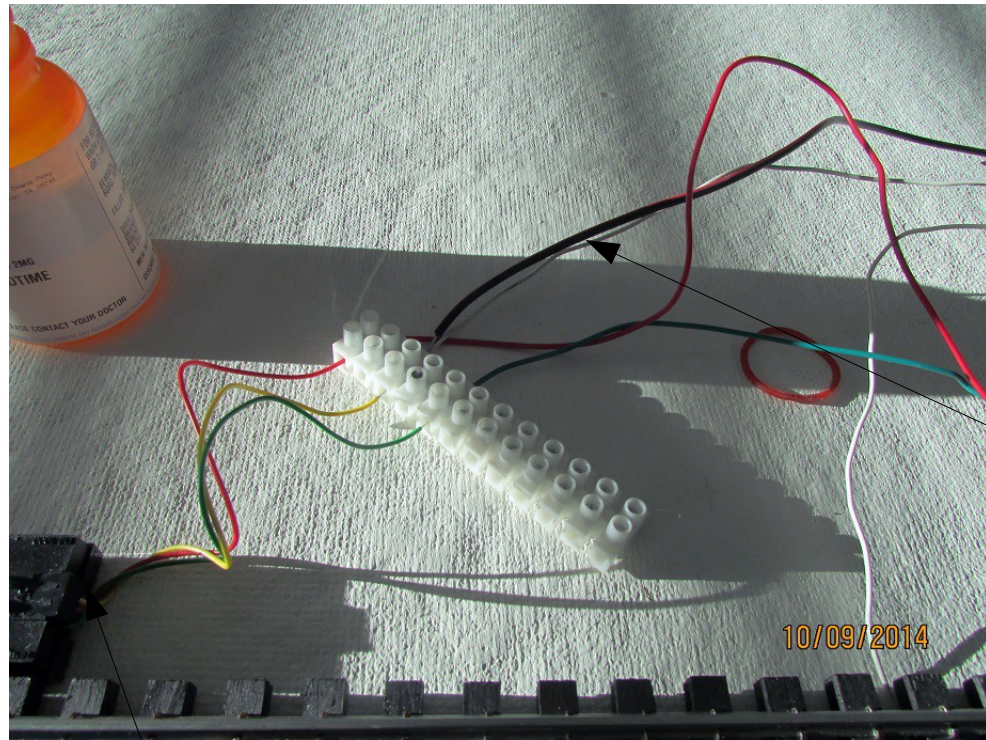

Wire from isolated rail

Switch machine (yellow wire is L terminal)

# Ross Double Crossover Wiring for Non-Derail and Power Diamond Rails

## Powering Diamond Rails

The RossReady double crossover is already wired underneath the switch so that power will continue through without interruption for most equipment. (It is isolated from track to track). However, it may be necessary to power the diamond rails (rails 1 & 2) using a relay if you are running equipment with rollers on only one set of trucks (i.e. Lionel's Gp-9)

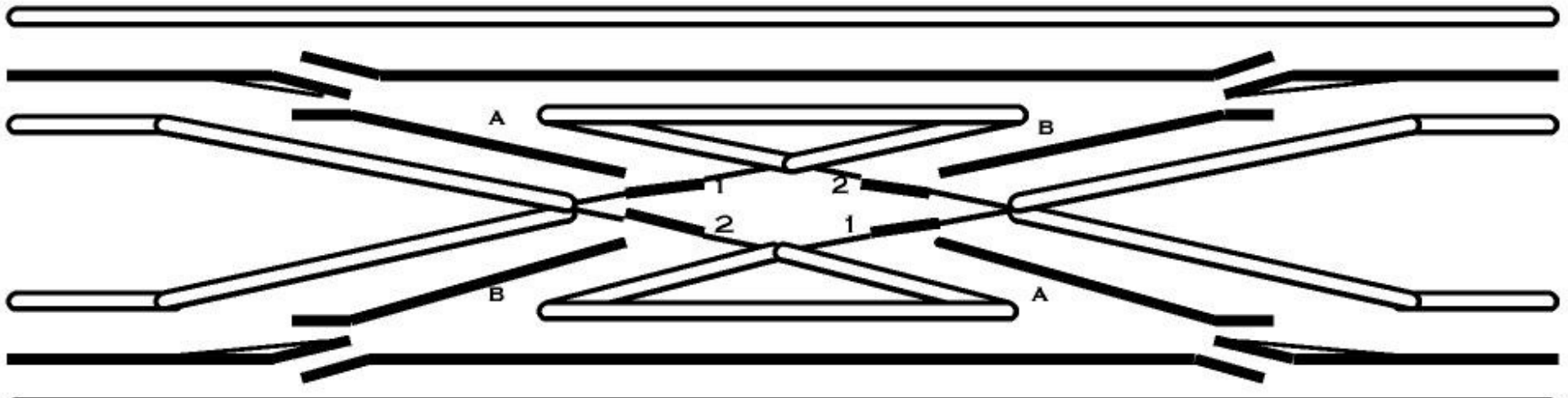

Use the DZ 1008 relay (could also use Atlas O Snap Relay) to power rails 1 and 2 in the diamond. Diamond is non-conductive. All four rails are isolated from each other and normal track. Therefore each rail will need its own wire.

# Ross Double Crossover Wiring for Non-Derail and Power Diamond Rails

## Powering Diamond Rails

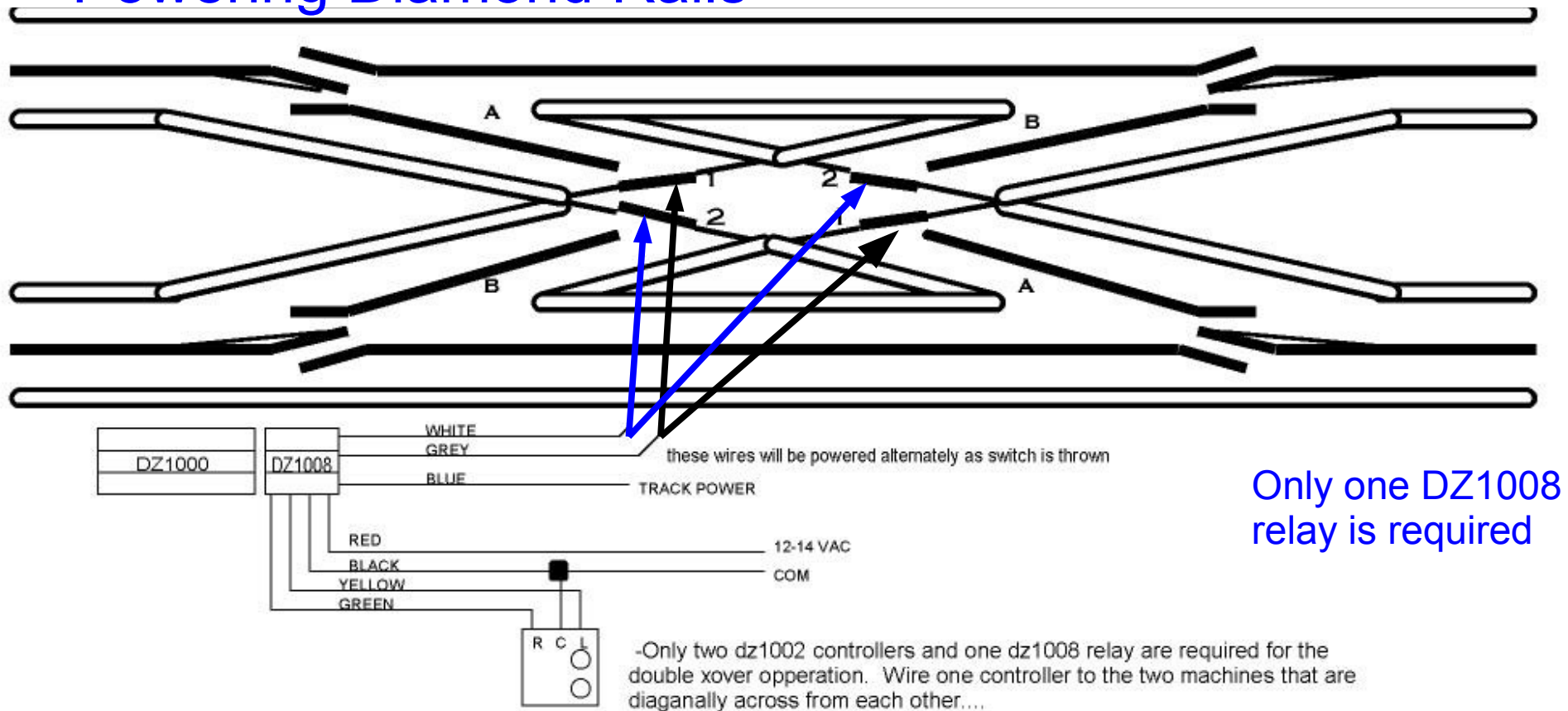

Only one DZ1008 relay is required

General wire scheme for the DZ 1008 relay (could also use Atlas O Snap Relay) to power rails 1 and 2 in the diamond. When the DZ1008 is connected power to the gray wire is always on unless the relay is activated for route "B". Then the gray wire is turned off and the white wire is turned on. When activated route "A" the gray wire is powered. Having the gray wire powered when the crossover is set for through (straight) is ok since the pick up rollers do not go near the diamond rails.

# Ross Double Crossover Wiring for Non-Derail and Power Diamond Rails

## Turnout Wire Scheme Including DZ 1008 Relay

