

SUNCOAST COALING TOWER

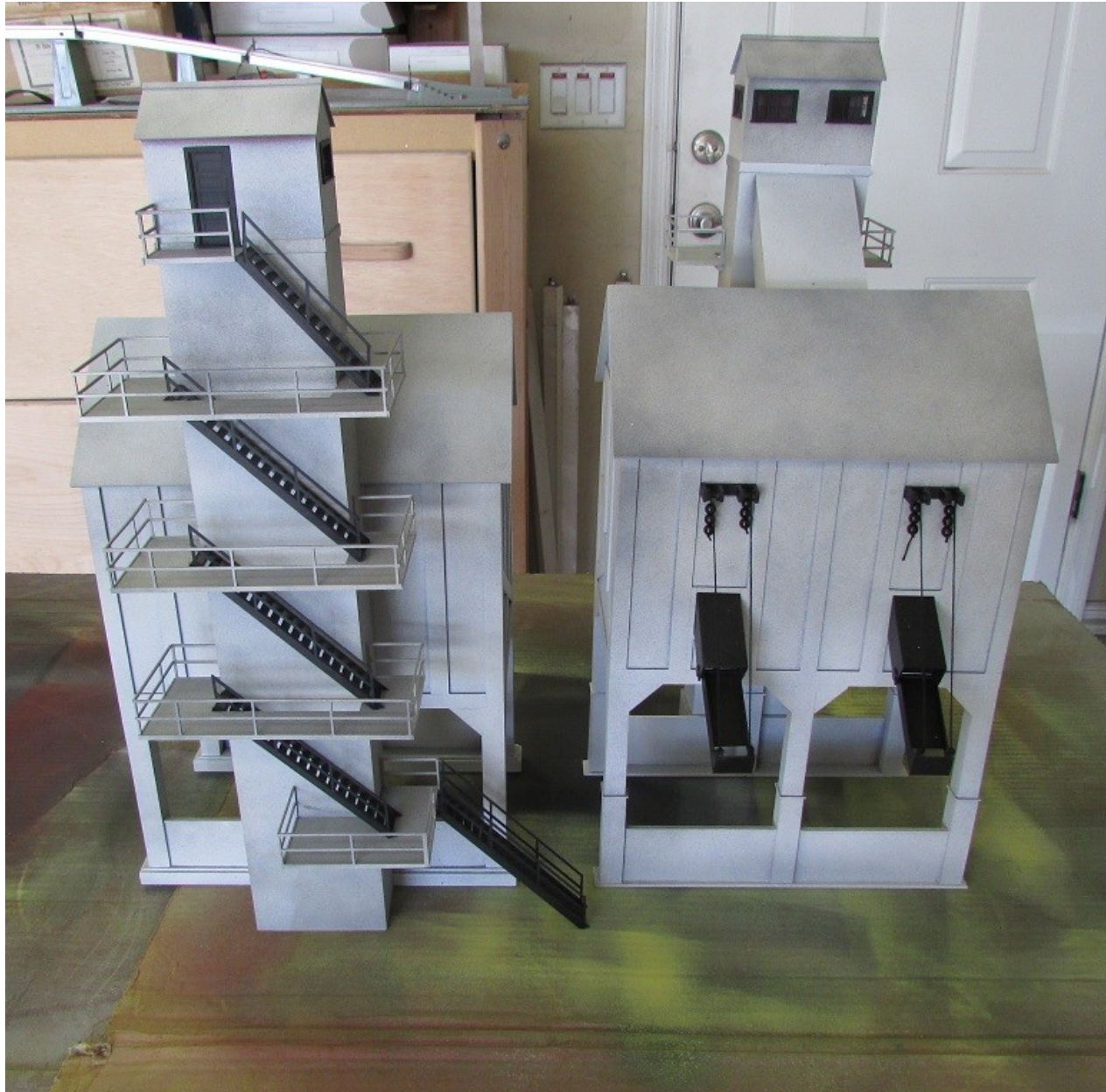

SUNCOAST COALING TOWER

The basic issue with the Suncoast 200 Ton Tower kit is that if built to instructions the pass through is too low for some of today's scale steam locomotives. The designed height of the pass through is ~ 4 ½ inches. As shown below place a scale locomotive on track on top of roadbed and the smoke stack tends to the bottom of the coal bin



SUNCOAST COALING TOWER

The redesign is shown next to the kit design. The legs have been made taller and broken up by a mid level sectional piece. The wood base has been deleted making this a 100% plastic construction.

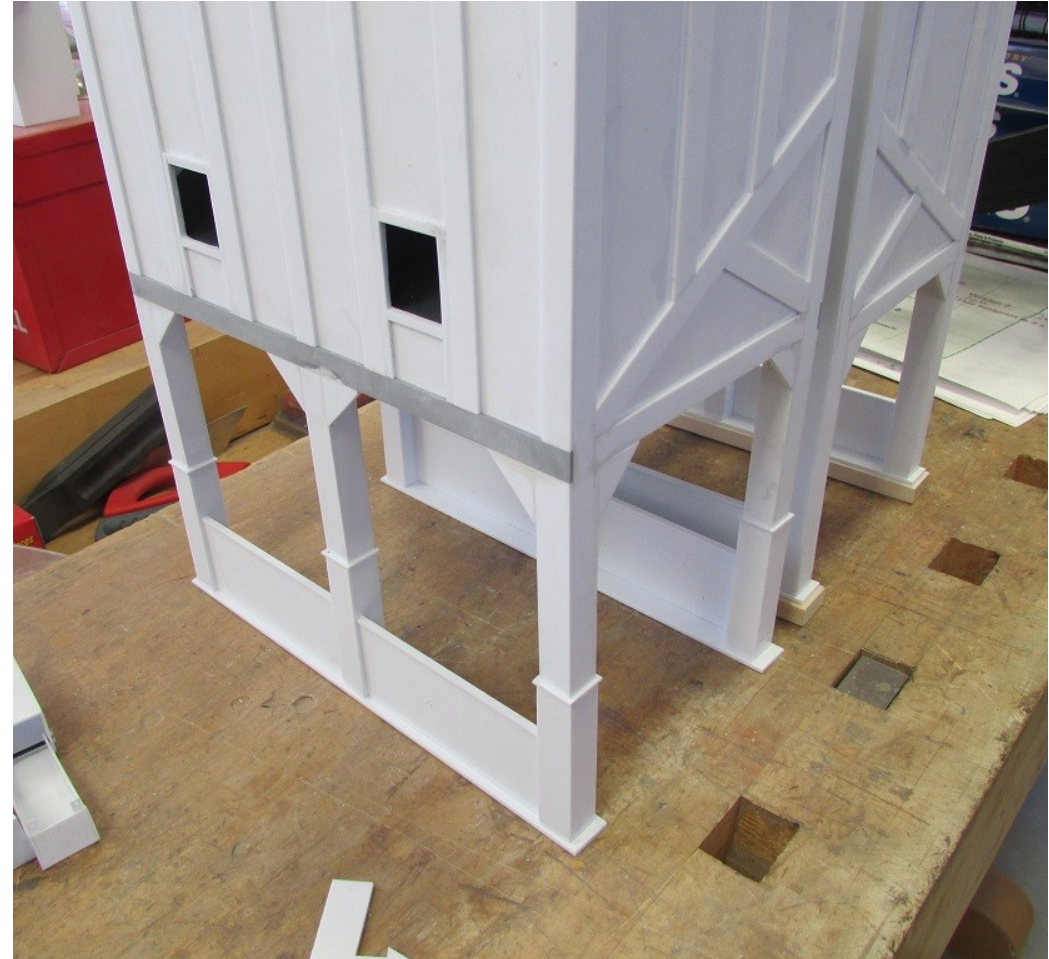

SUNCOAST COALING TOWER

Coal Chute

I did not like the kit design for the coal aprons so search the internet and found pictures of the design shown above. This is much more 'substantial' and pivots up and down. The chutes are made with 40 mil styrene stock. Build chutes and aprons first so you can size holes in wall. It is much easier to use nibbler before walls are glued in place.

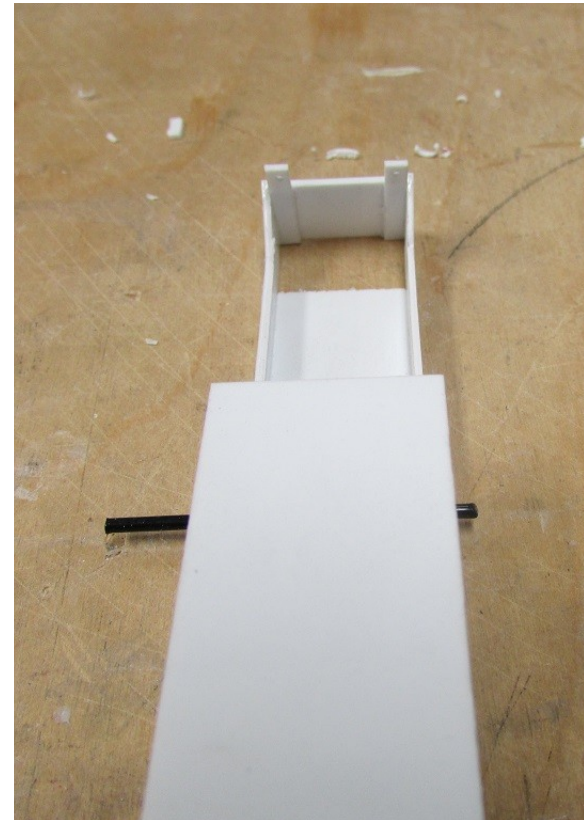
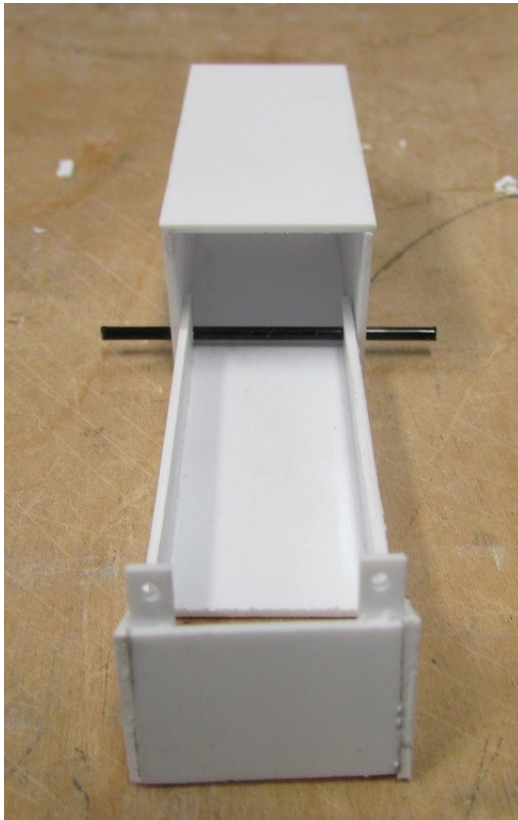

SUNCOAST COALING TOWER

Coal Chute

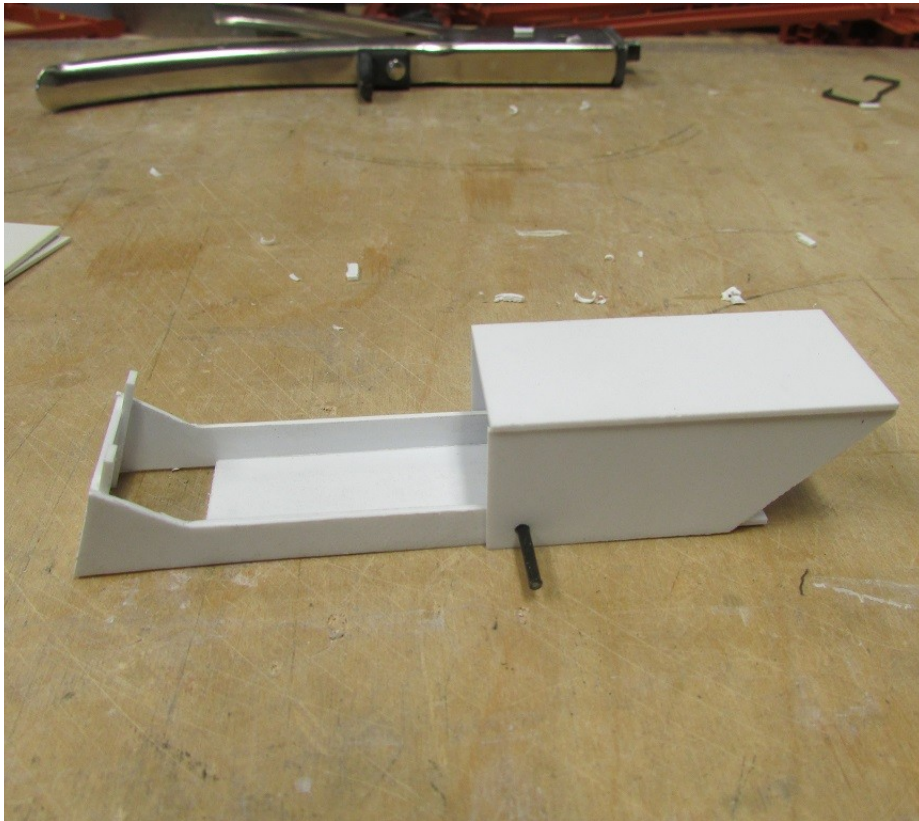

If available use round punch to cut discs to cover holes otherwise cut small styrene squares

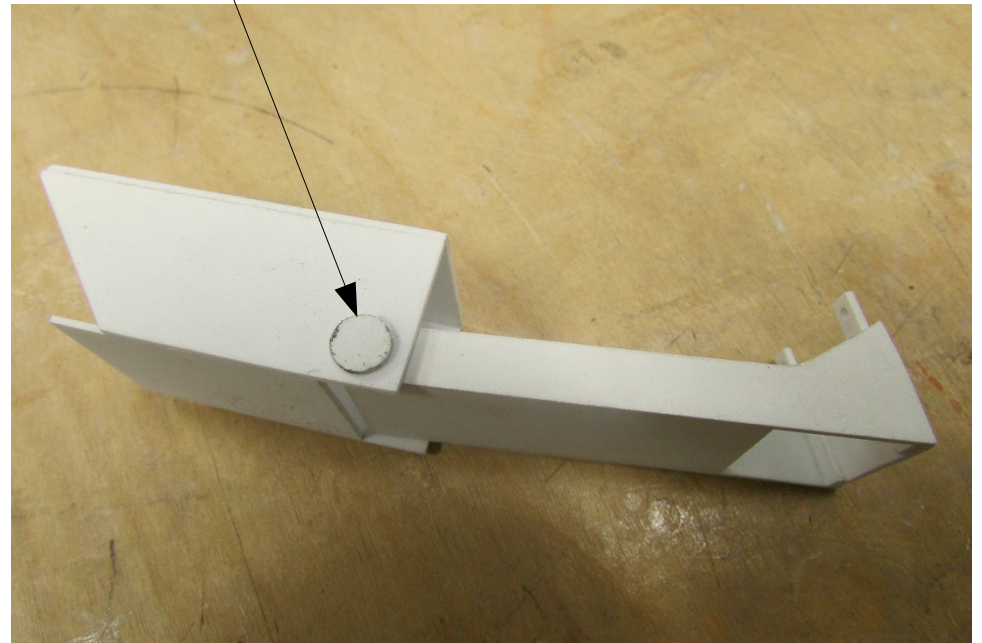

SUNCOAST COALING TOWER

Coal Chute

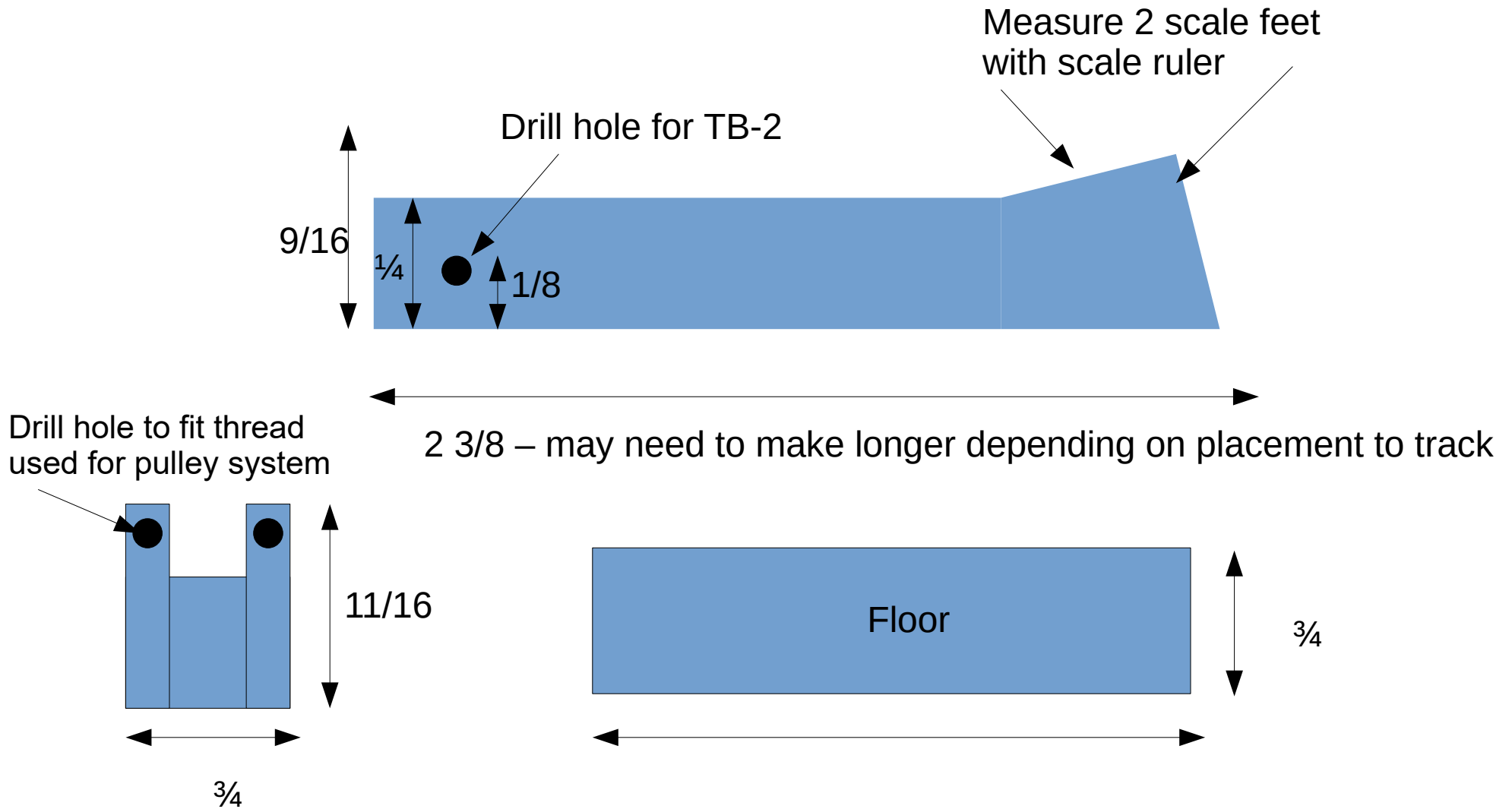

SUNCOAST COALING TOWER

Coal Chute

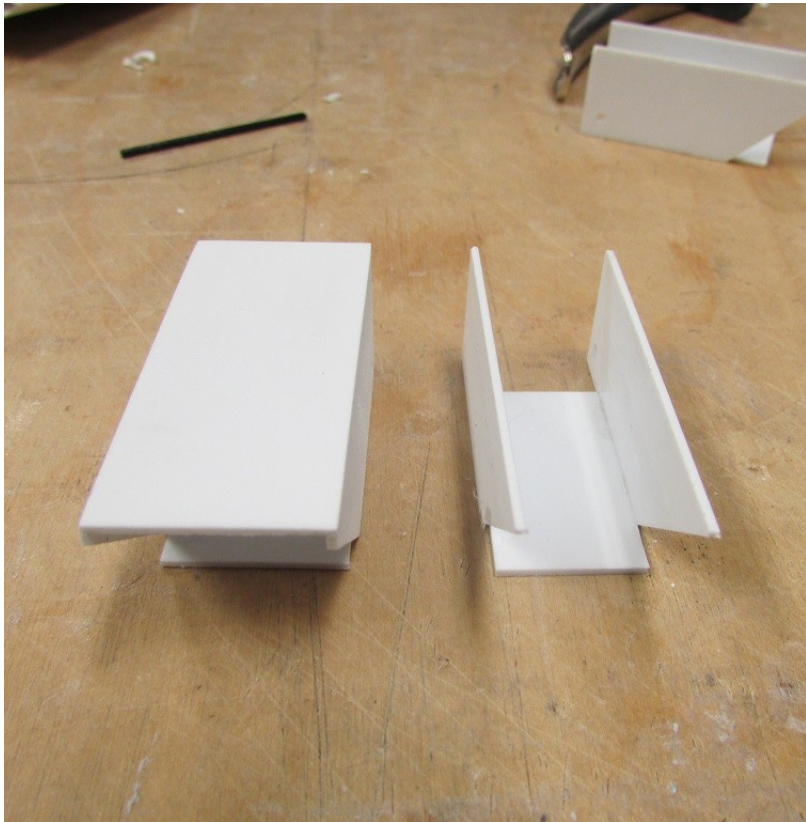

Chute must fit inside apron

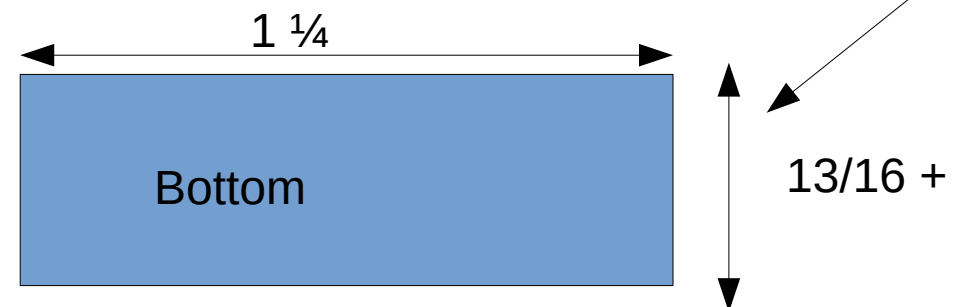
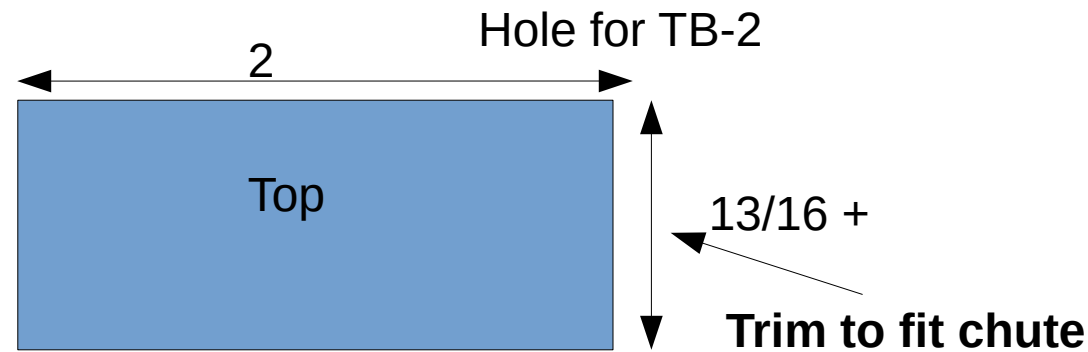
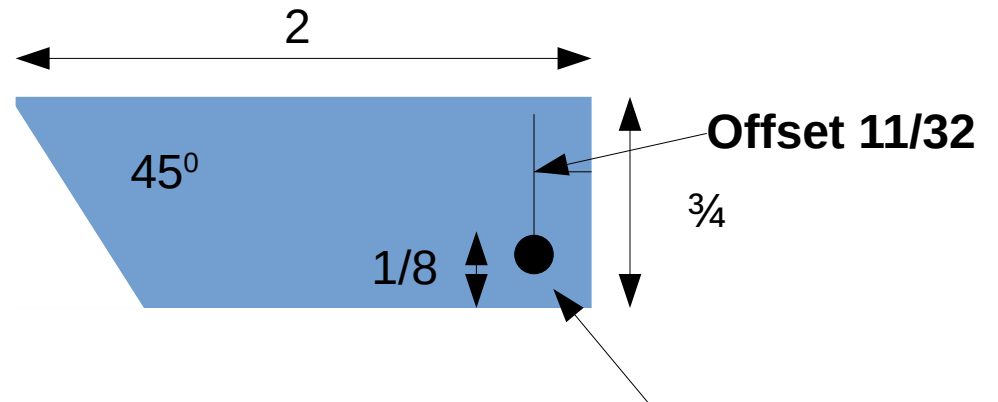

SUNCOAST COALING TOWER

Coal Bin

The coal bin is made from 80 mil white styrene sheet stock. 60 mil stock can also be used. The main coal bin. The kit has both wood and plastic components. The wood is used for bracing and the inside of the square legs. I don't much much like gluing plastic to wood so replaced almost all the wood with plastic pieces from Plastruct.

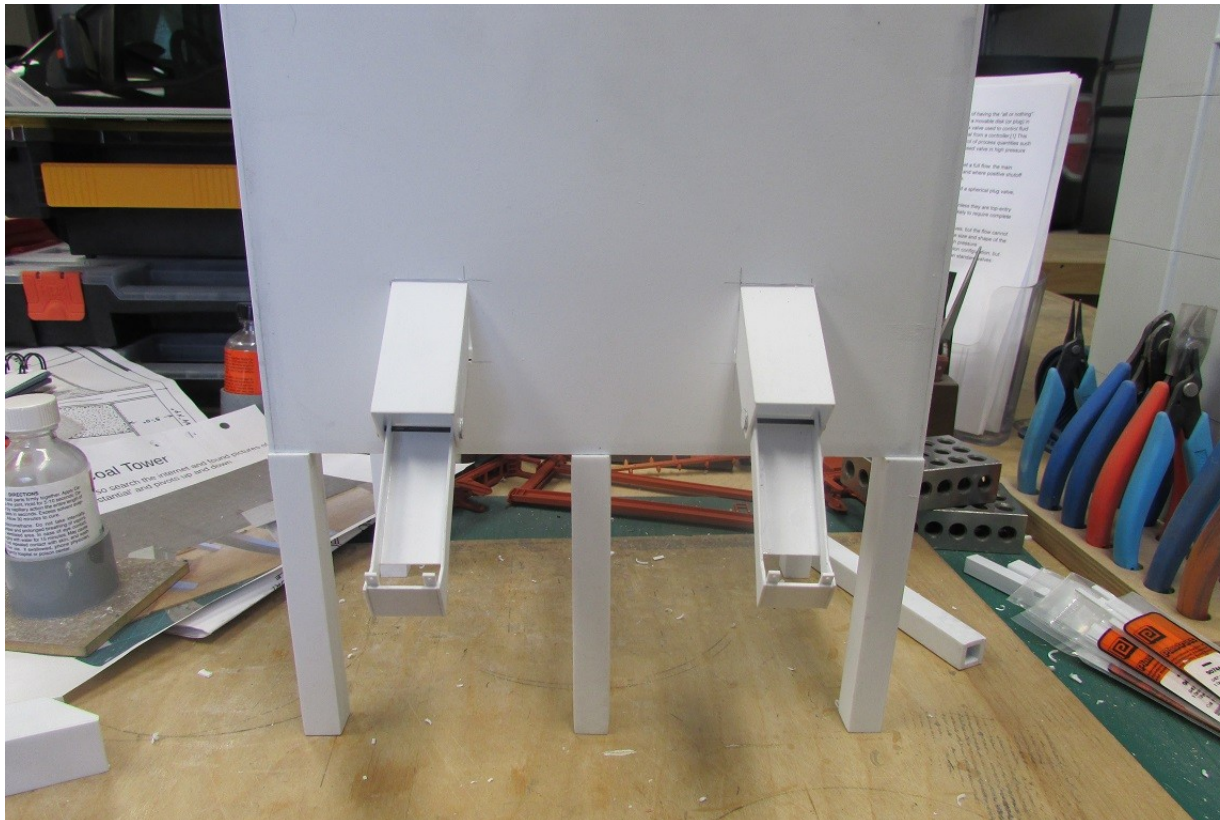

SUNCOAST COALING TOWER

Coal Bin

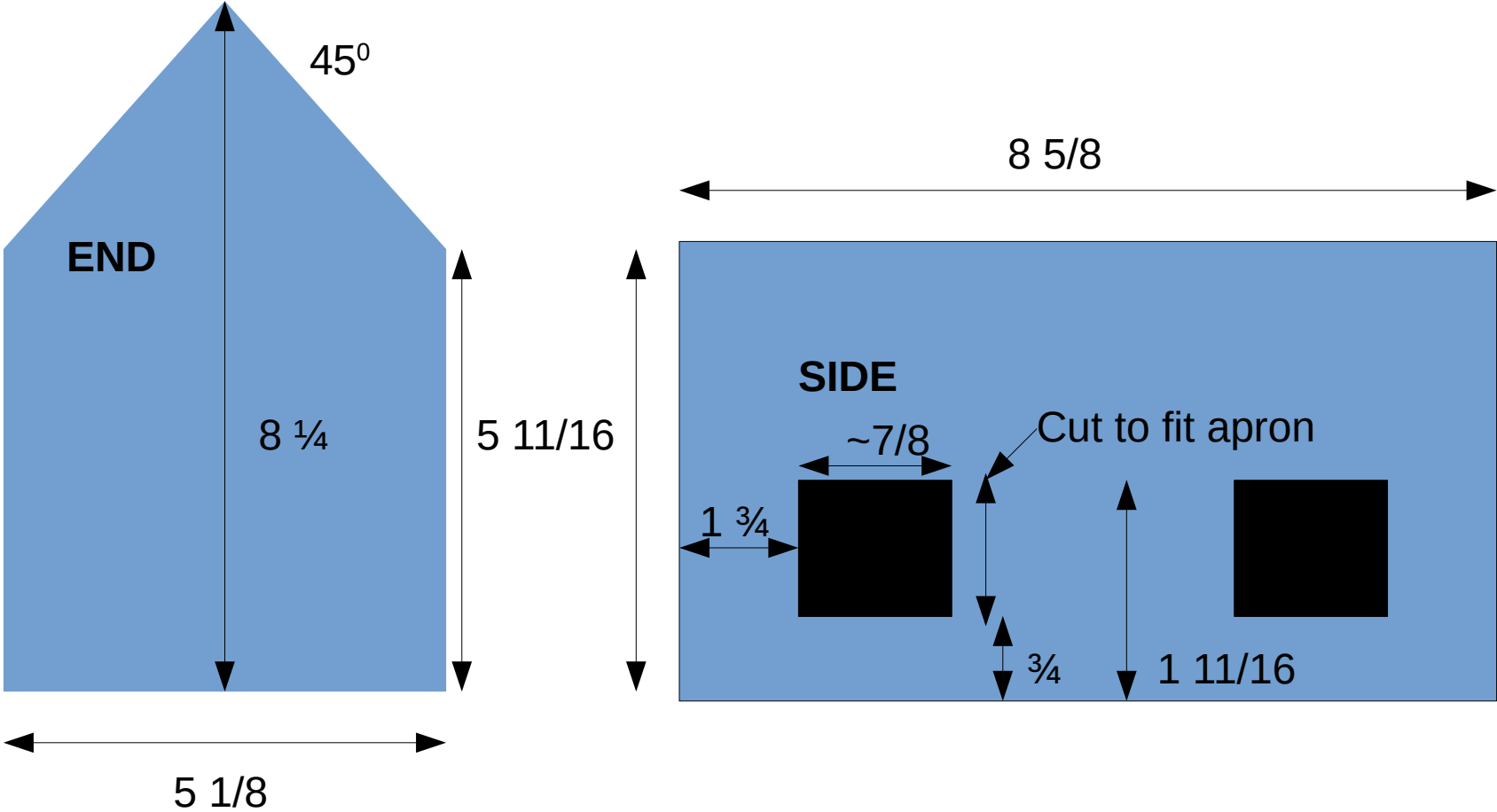

SUNCOAST COALING TOWER

Coal Bin

Plastruct MS-190 square rods are used as corner and roof supports.

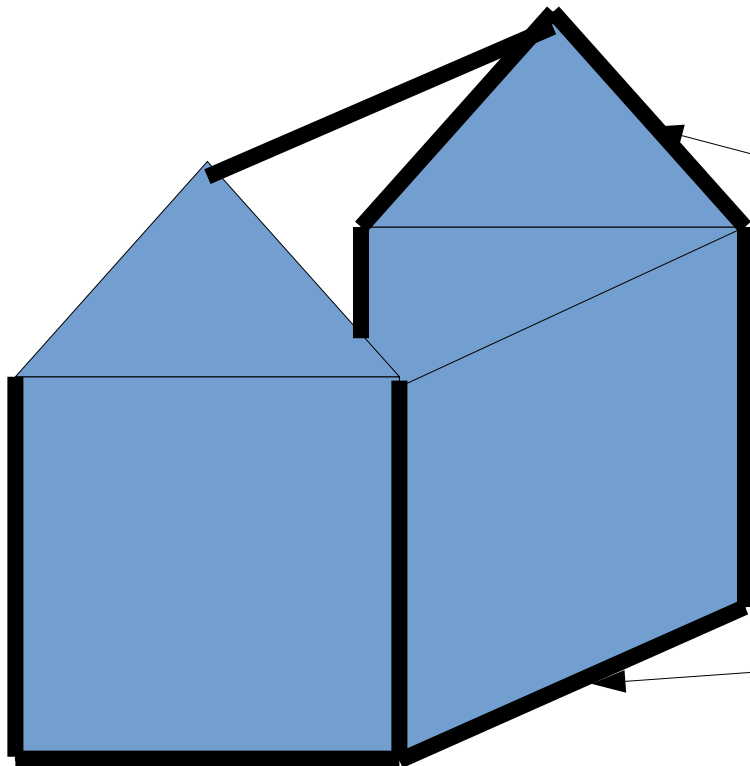

MS-190 on all inside corners

On bottom MS-190 – don't place until legs are glued in

SUNCOAST COALING TOWER

Coal Bin

The legs can be made with 3/8 square basswood with 20 mil flat styrene laminated on each side. I prefer Plastuct ST-12 square tubing laminated with 80 milk stock. Build legs and sand flat before gluing to bin. Legs on chute side are cut to length so that they are about 20 mils below the bottom of the cutout for the chutes. The legs on the opposite side are cut to length so that the bin floor will fit at a 45 degree angle.

SUNCOAST COALING TOWER

Coal Bin

Glue legs to coal bin first then laminate ST-12 on two sides only (end pieces) and three sides for middle pieces. Glue to coal bin wall then laminate the outside with with SSS-108 or -106 depending on the wall thickness.

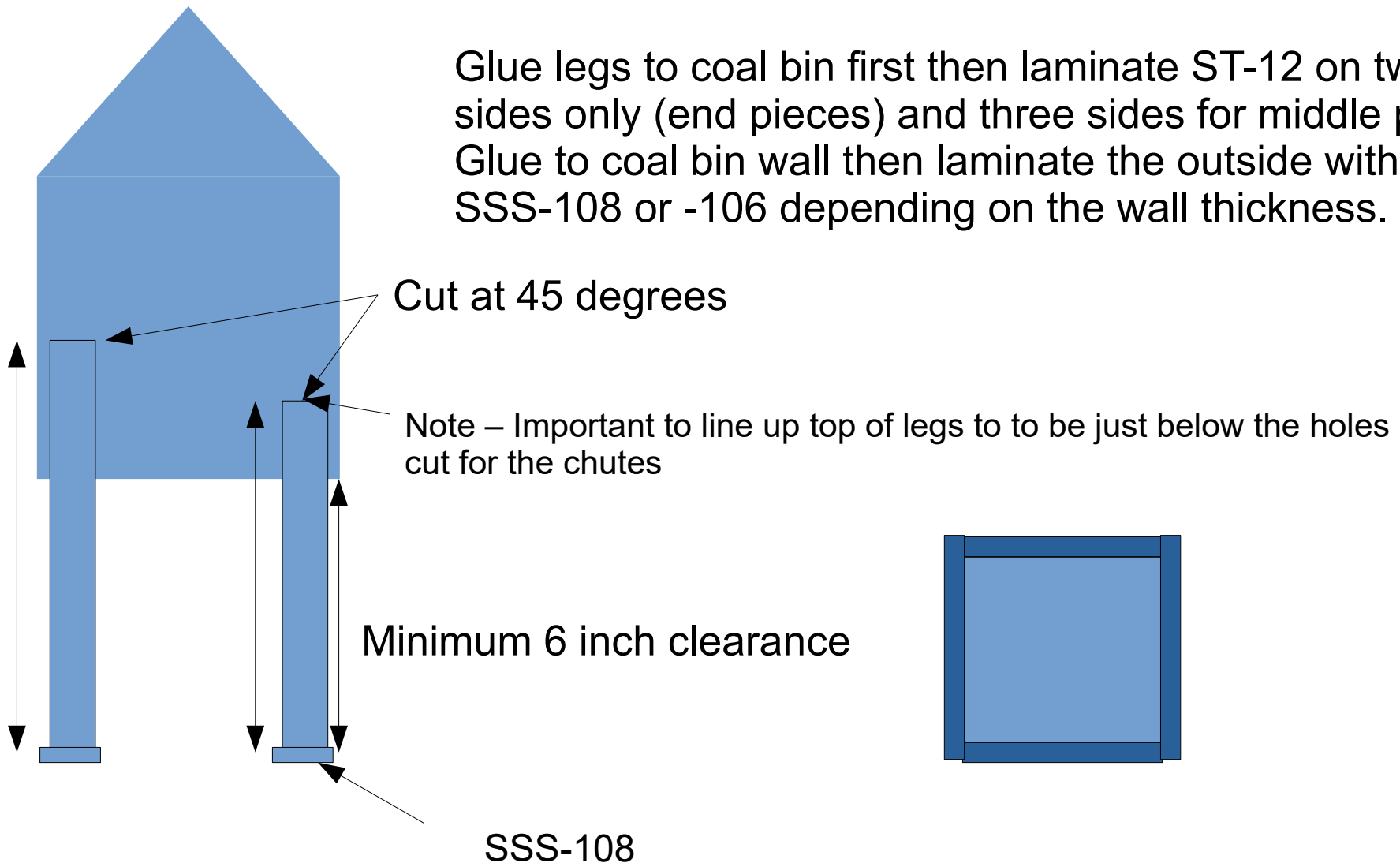

SUNCOAST COALING TOWER

Coal Bin

The bin floor can now be added. If available use black styrene minimum thickness 40 mil. If white styrene is used laminate with thin 20 mil black styrene. Once the roof is glued on it will be impossible to paint the interior

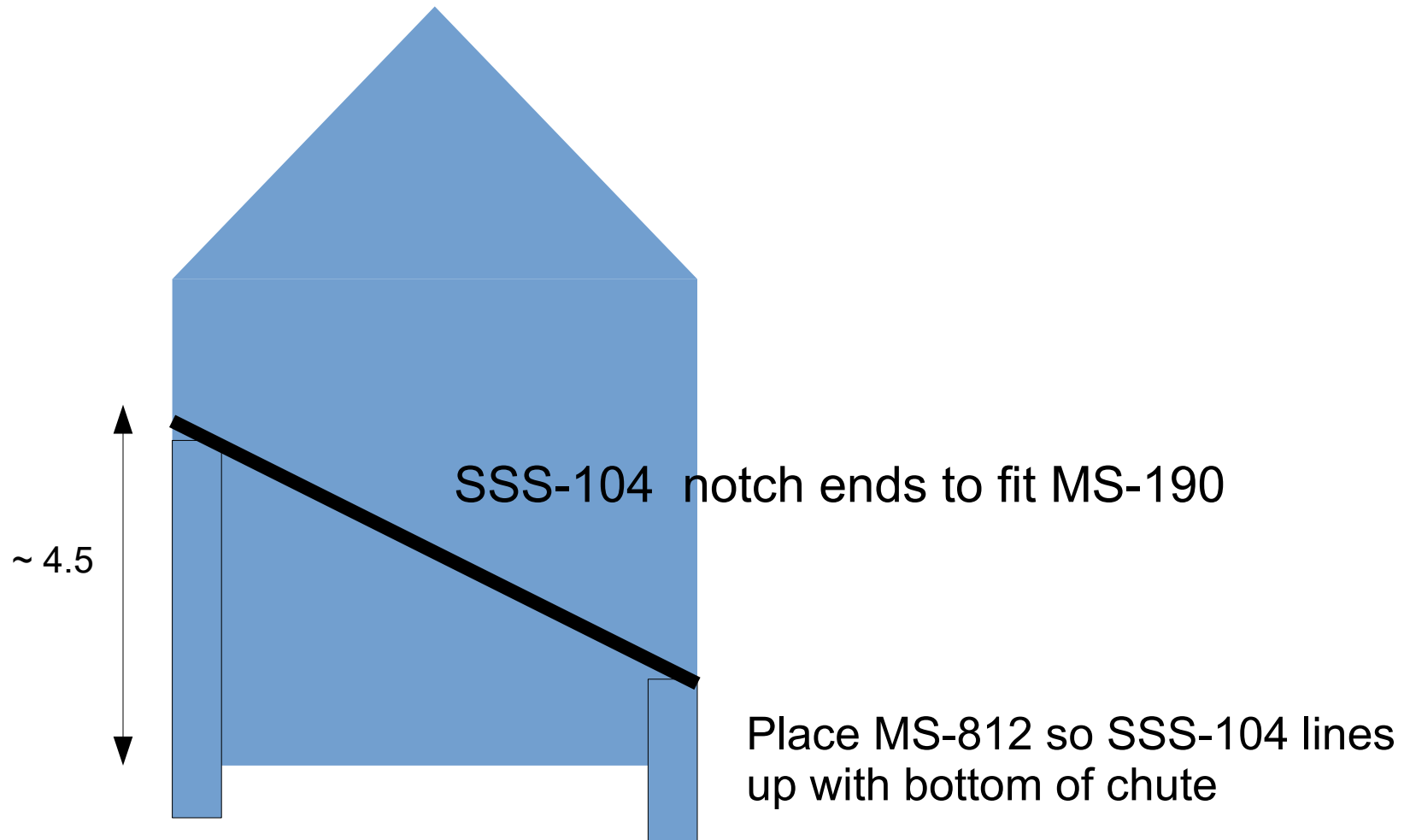

SUNCOAST COALING TOWER

Coal Bin

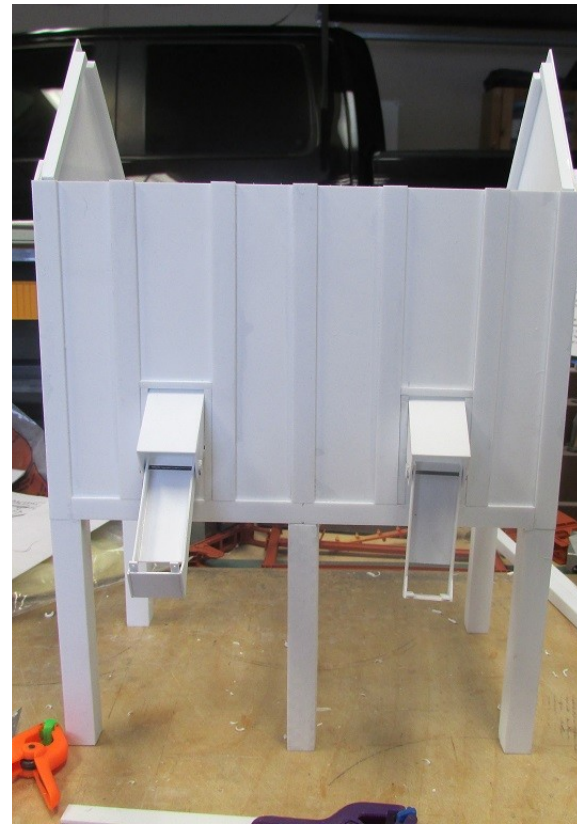
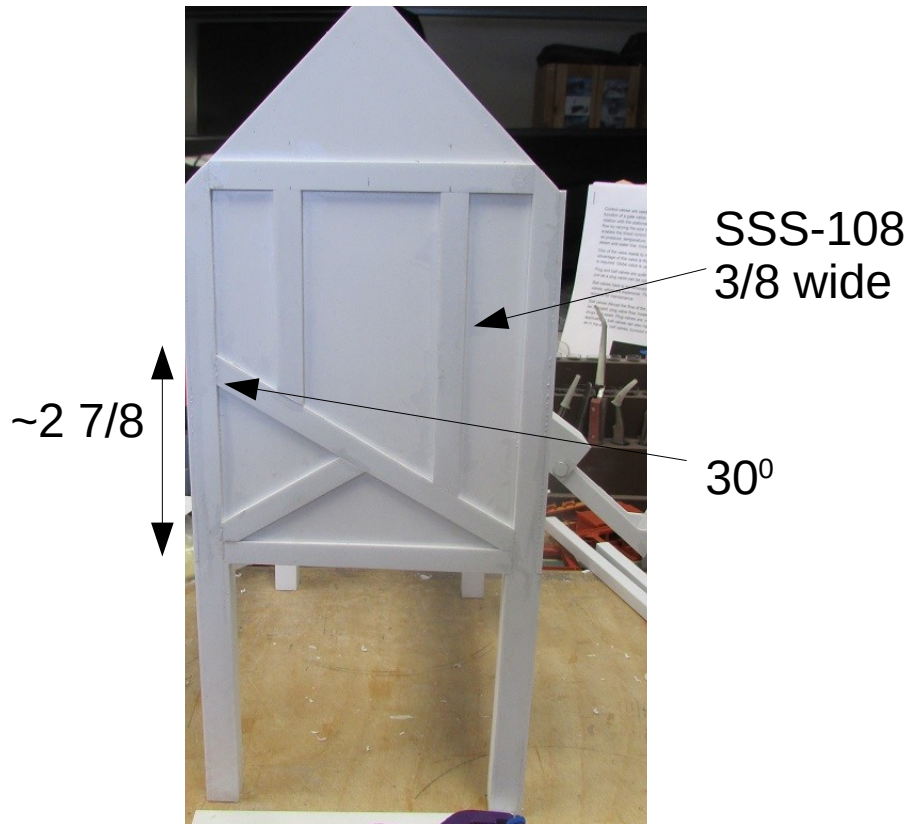

Glue on 3/8 wide strip on bottom
then enclose apron with MS-812
Then glue on remaining 3/8 wide
strips

SUNCOAST COALING TOWER

Coal Bin

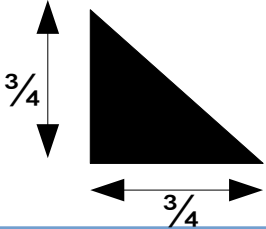
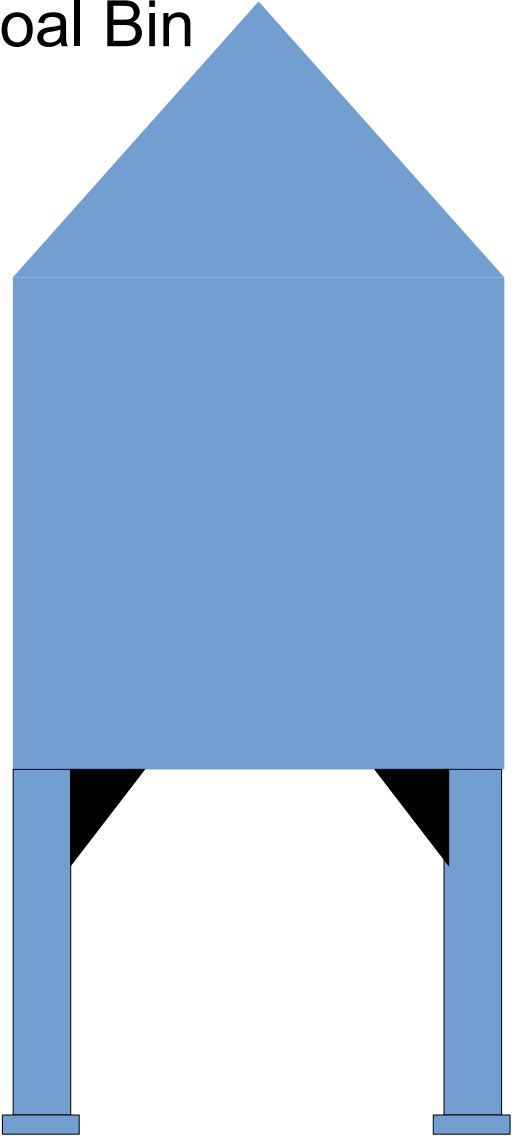

SSS-108 right triangles

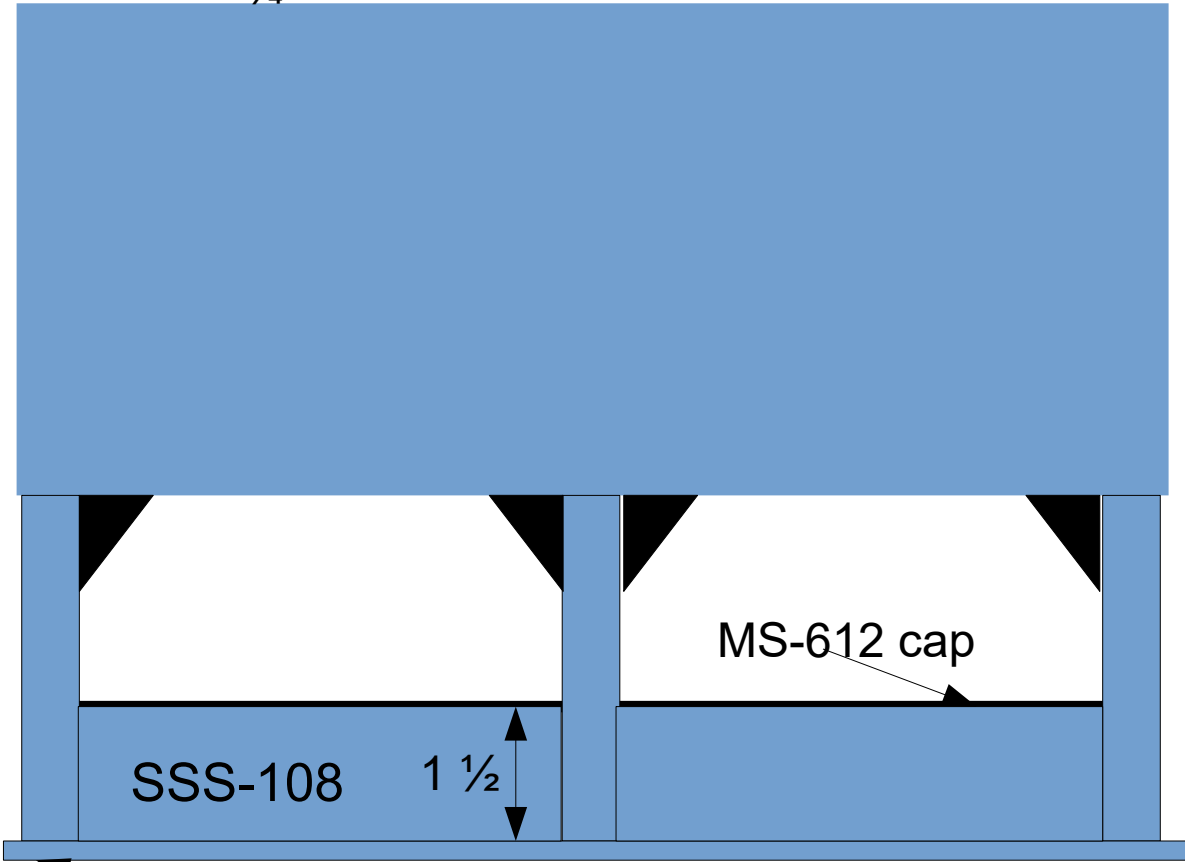

SSS-108 base $\frac{3}{4}$ inch wide – $\frac{3}{16}$ inch reveal on ends

SUNCOAST COALING TOWER

Elevator

Tower – 80 mil stock

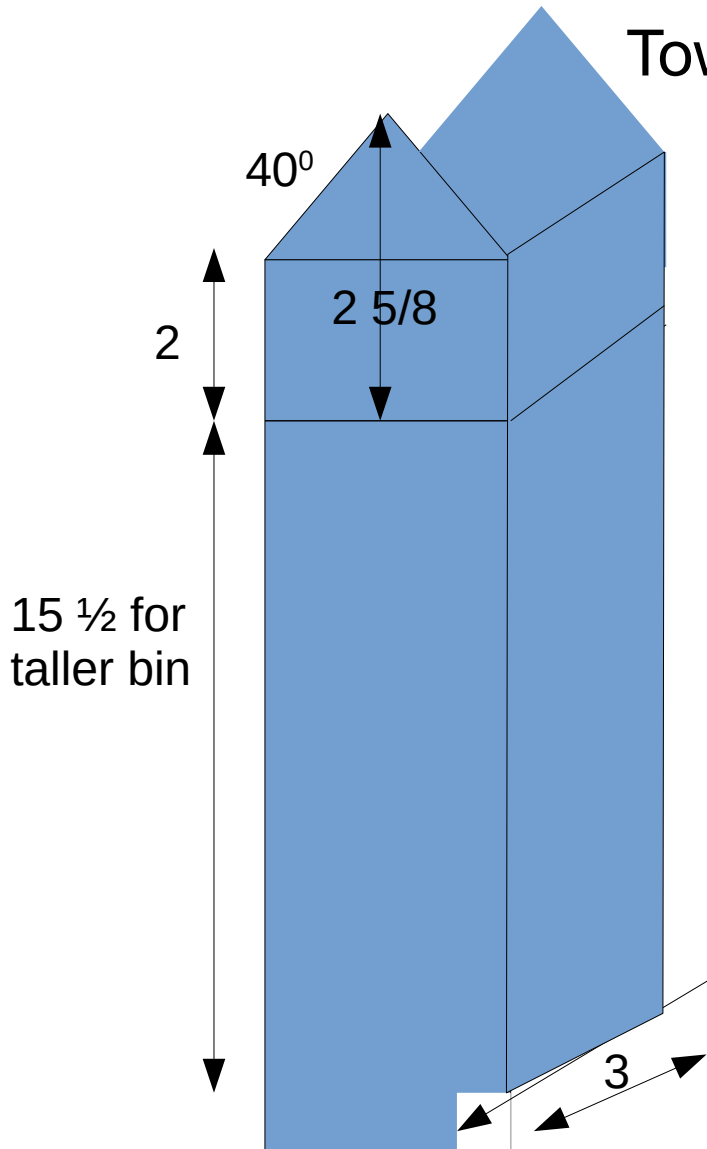

Notch for base

Before cutting the notch add the base to the legs

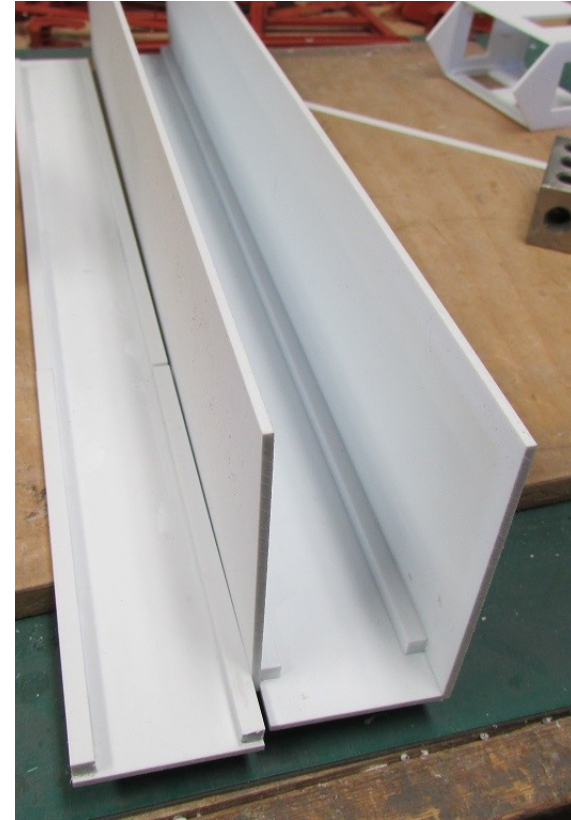

Use MS-190 on corners

SUNCOAST COALING TOWER

Elevator

MS-425



Make the top piece removable to allow changing put door lamp

SUNCOAST COALING TOWER

Stairways

The kit calls for 'build your own stairs'. I made the jig previously for wood stairs used with Suncoast's Ice Platform but this kit called for plastic stairways with small diameter wire for railings. I substituted Plastruct stairways and railings.

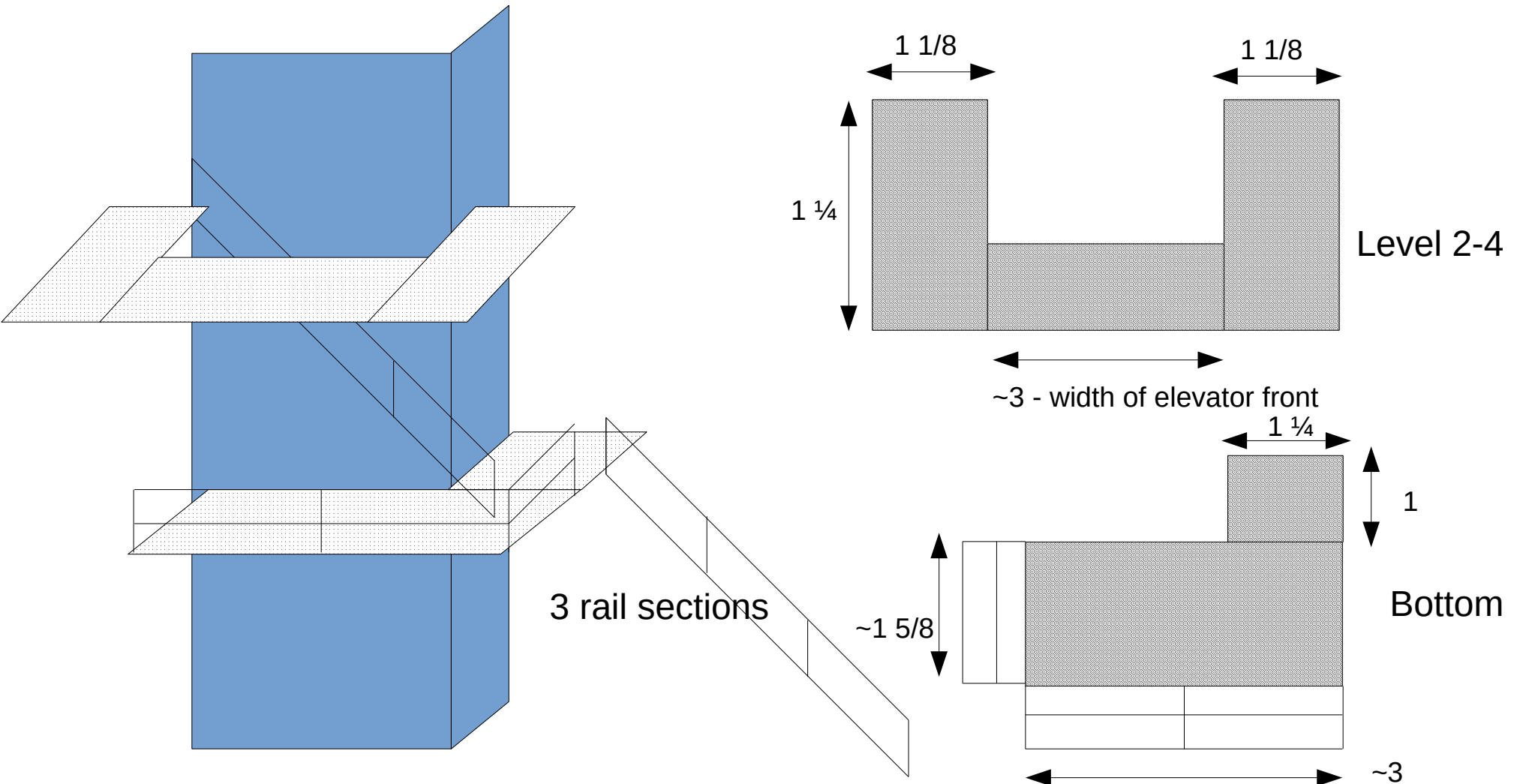

SUNCOAST COALING TOWER

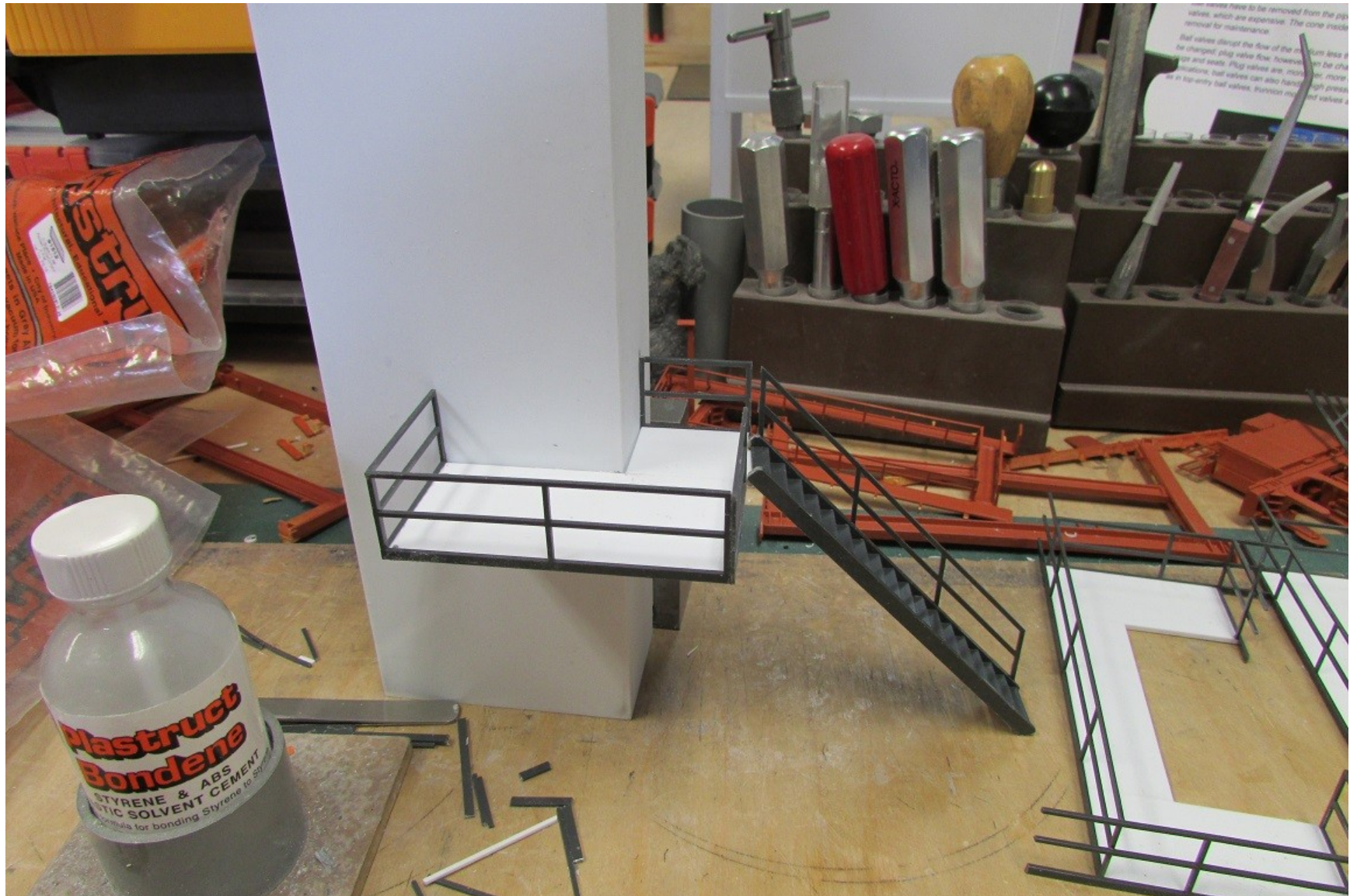

SUNCOAST COALING TOWER

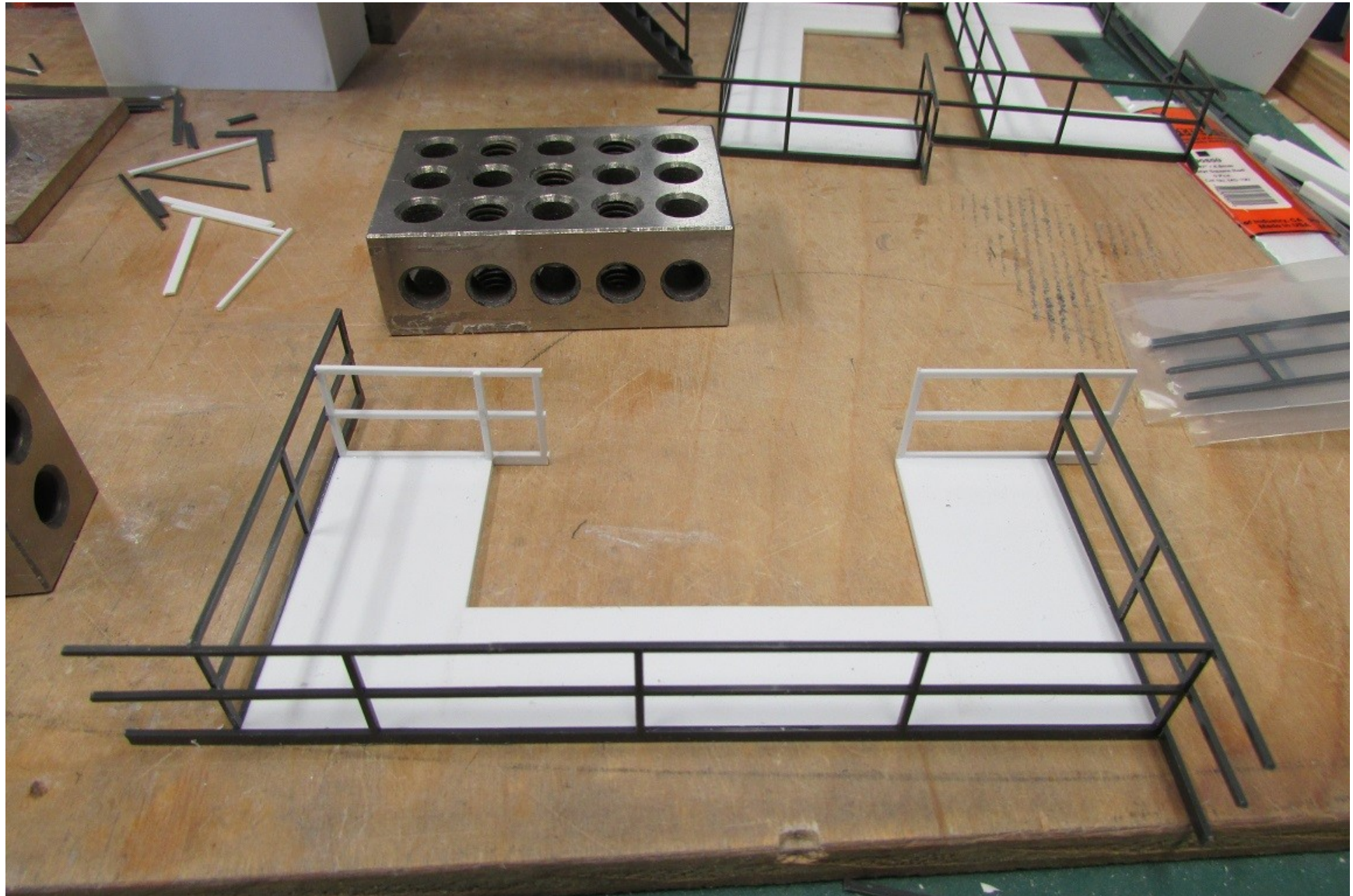

SUNCOAST COALING TOWER

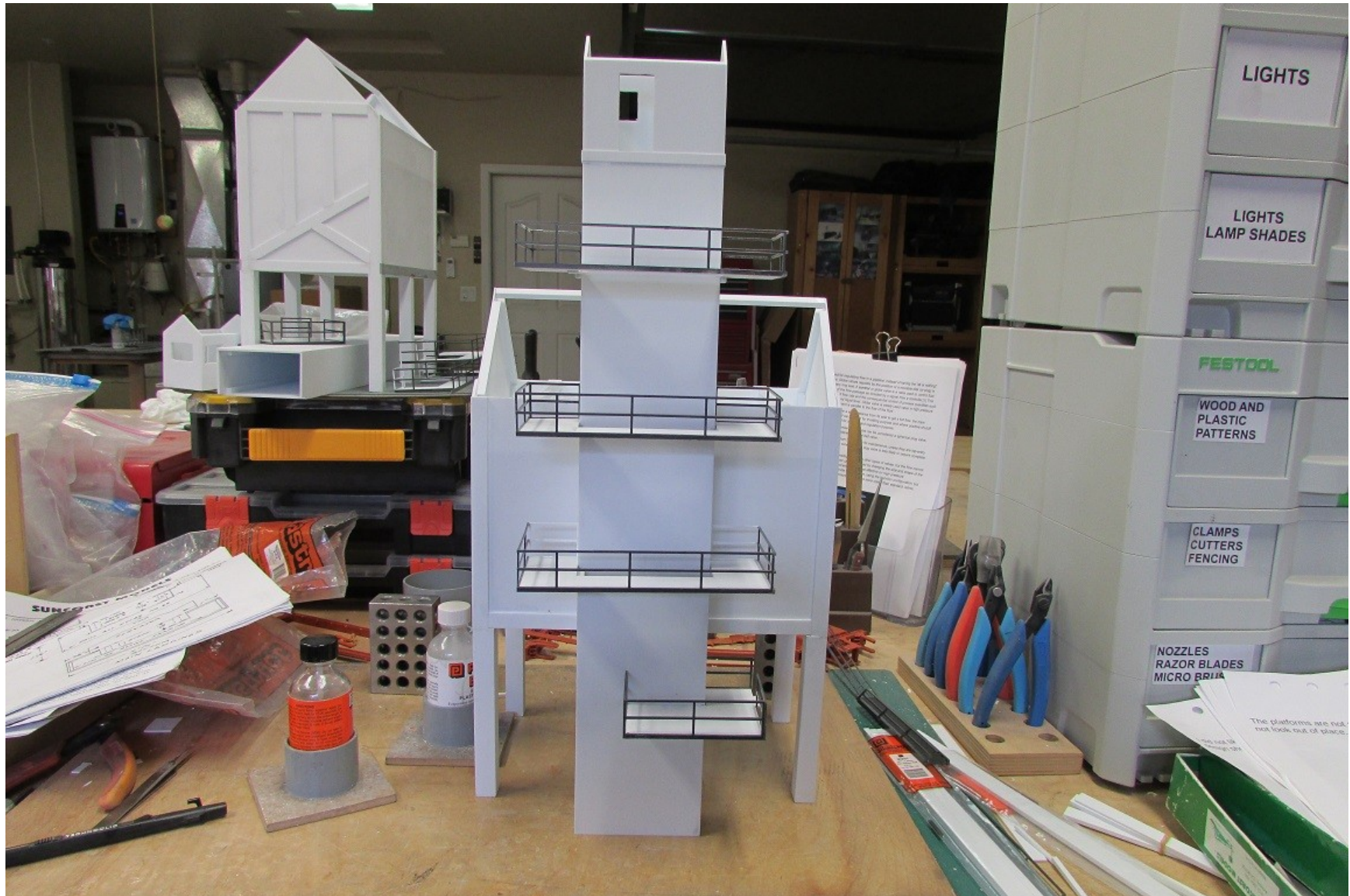

SUNCOAST COALING TOWER

Stairways

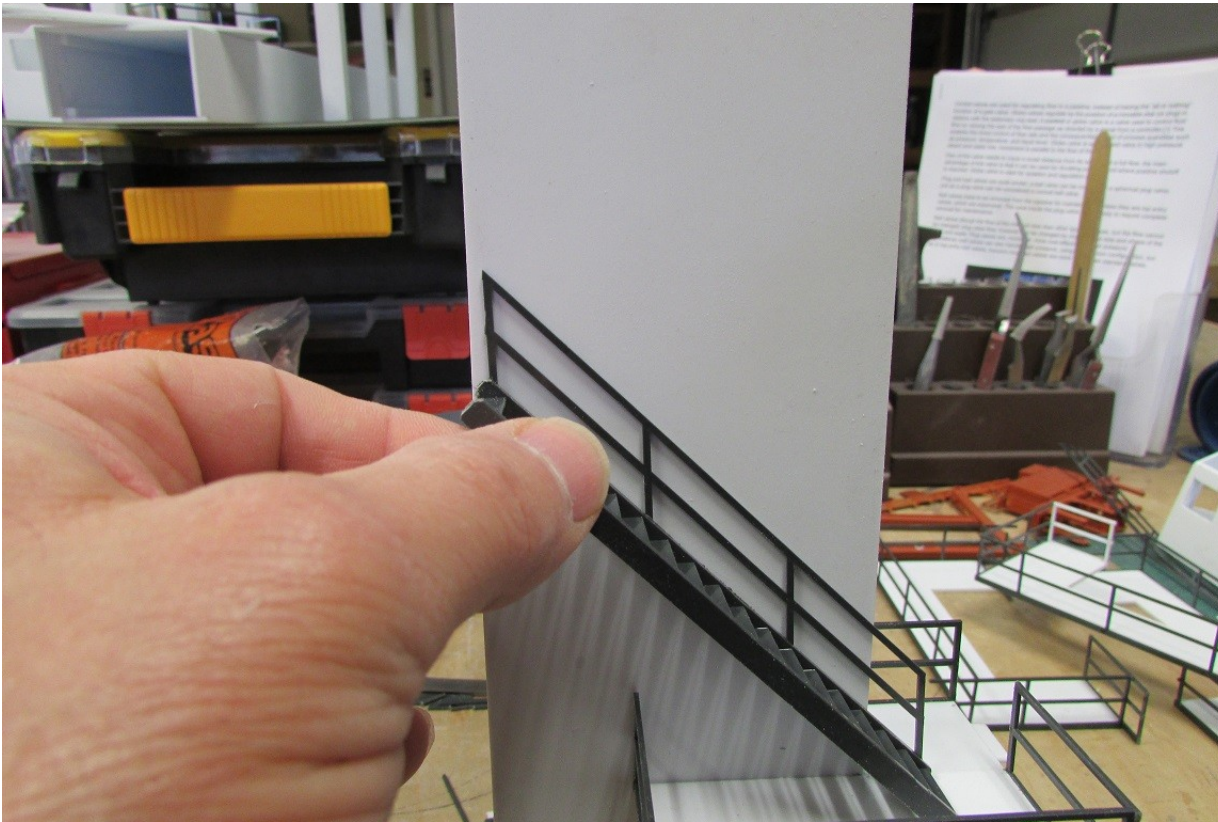

All floors except top floor get a stairway that has 3 sections of slanted railing.

Place the railing so that the vertical post is parallel to the edge of the conveyor house and mark where the top step is. This will give a pretty accurate place for the top of the next platform

SUNCOAST COALING TOWER

Stairways

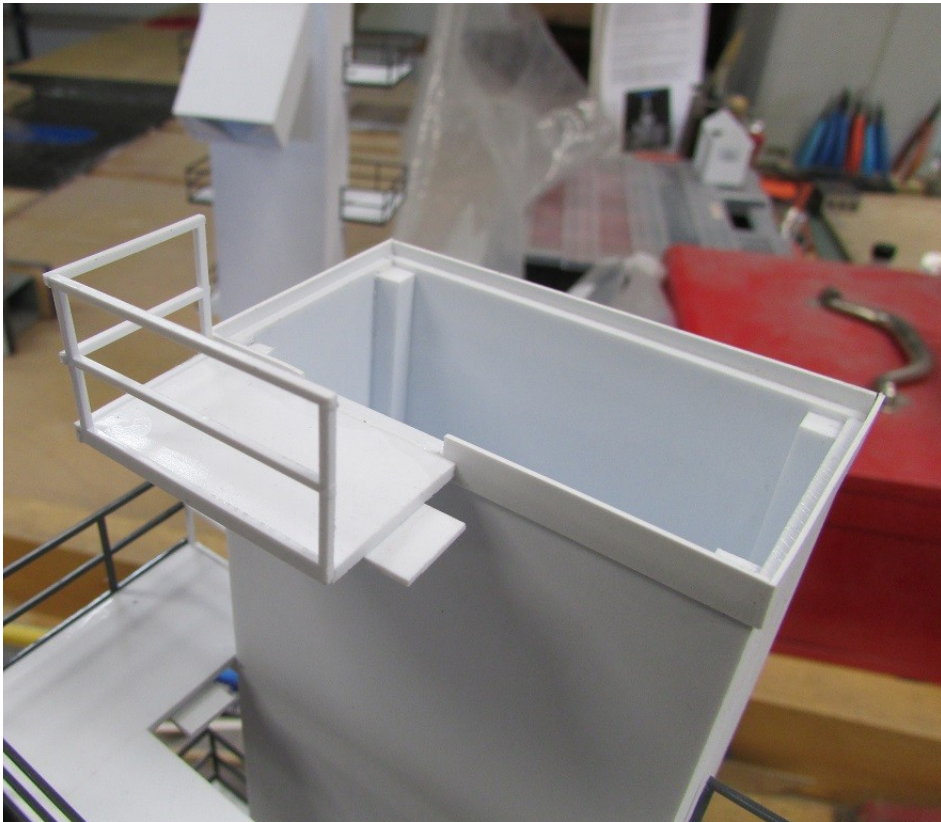

Top floor



Wide enough for
stairway

Make one rail section long

SUNCOAST COALING TOWER

Conveyor

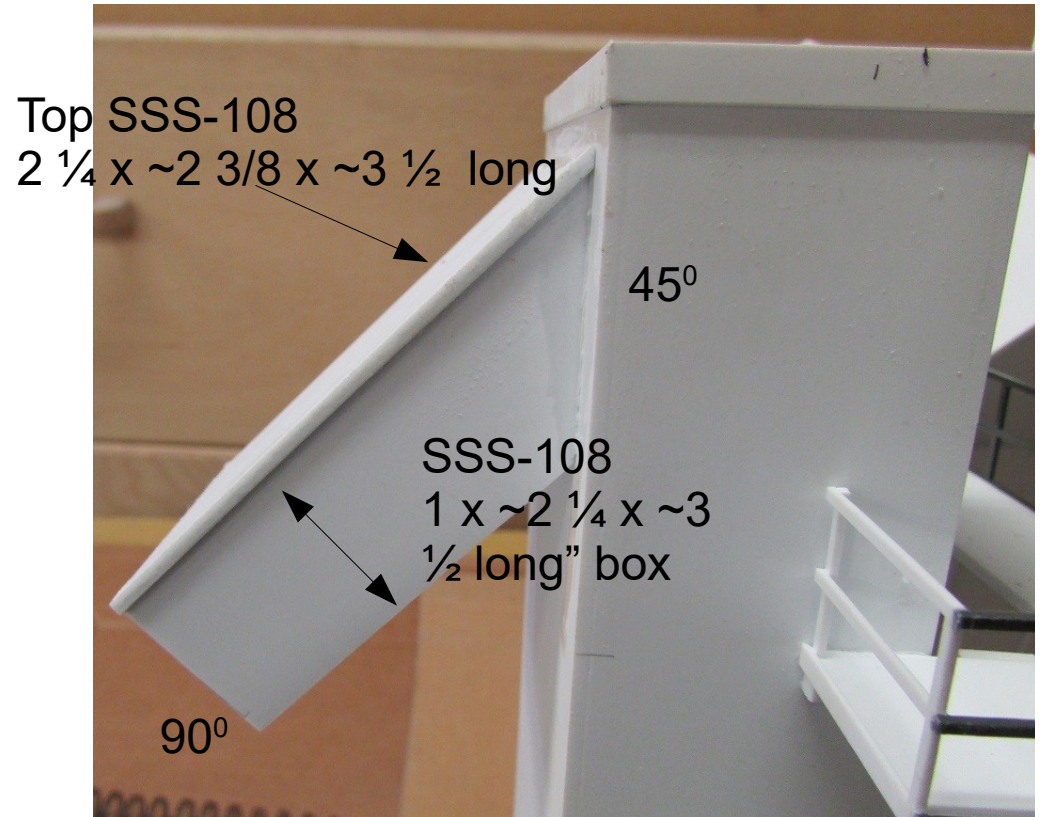

Build conveyor long and trim 90 degree end to fit – note top overhangs case. Glue conveyor to elevator but not to bin until after paint. Mark position on bin and tape area.

SUNCOAST COALING TOWER

Coal Chute Lift Mechanism

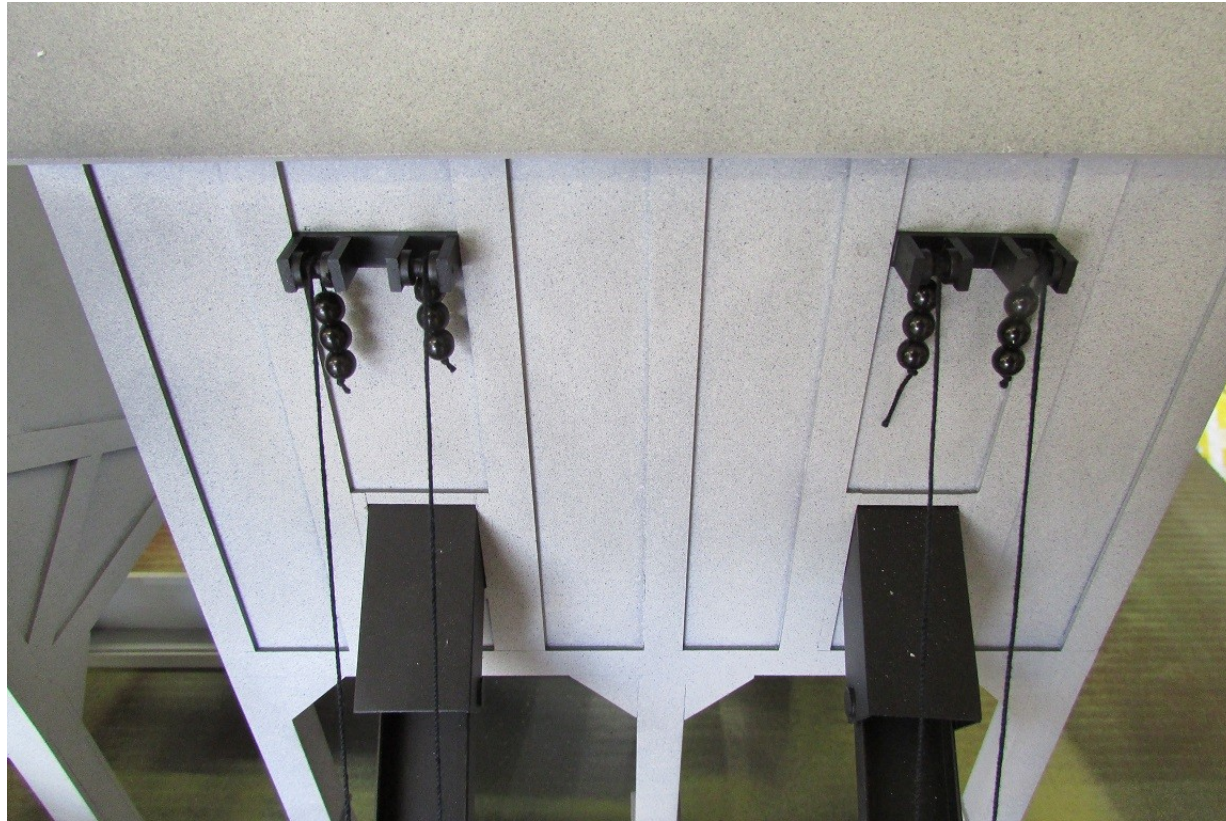

SUNCOAST COALING TOWER

Coal Chute Lift Mechanism

Two SX-2 end to end

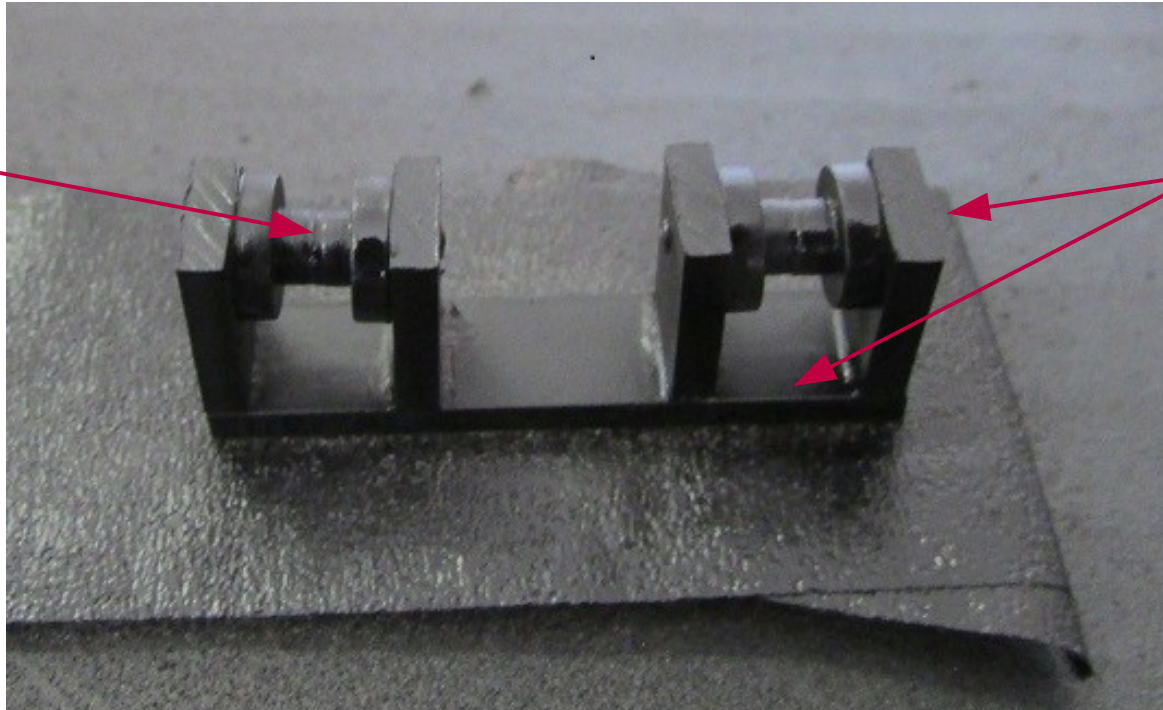

MS-825 brace

Drill holes in MS-825 to accept TB-2 tubing. TB-2 is plastic coated wire so will hold up to wear and tear. Set up each assembly and glue to MS-825 base as a unit. The SX-2 can be glued in place or left loose.

SUNCOAST COALING TOWER

Dump pit

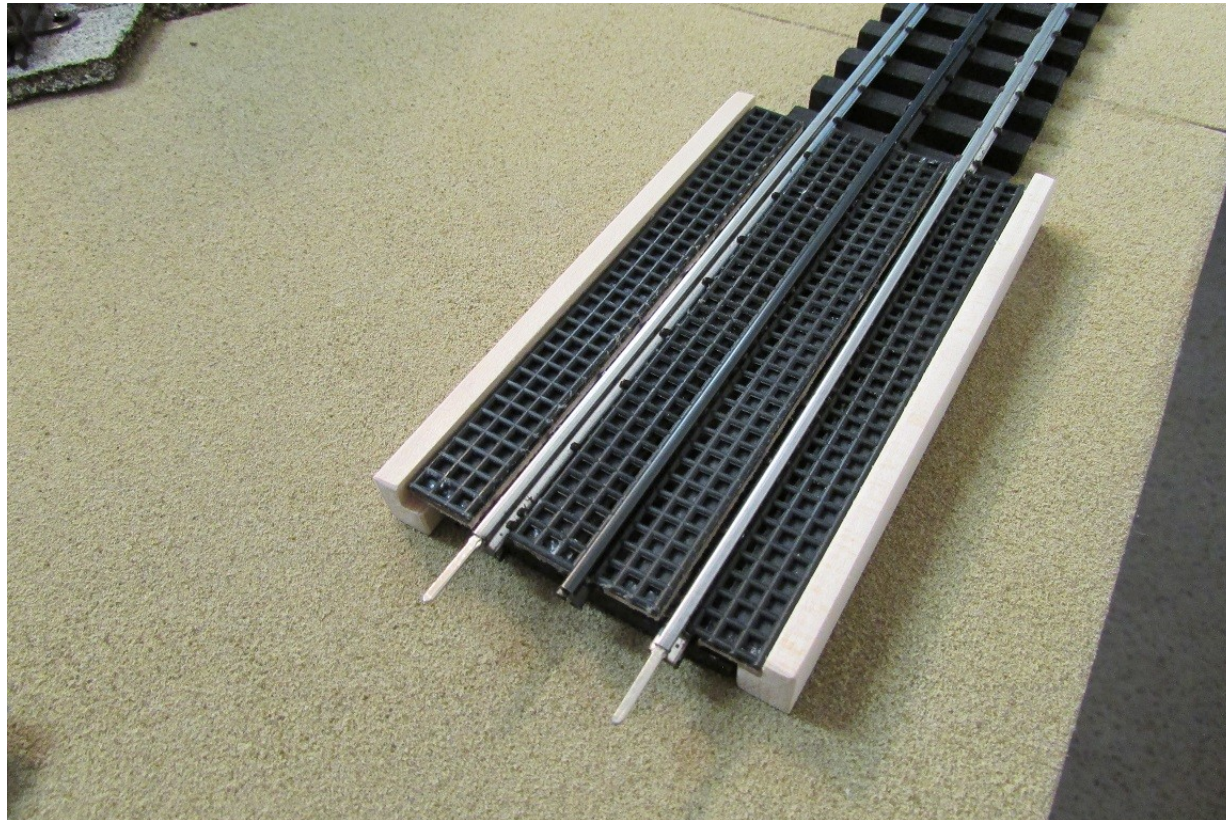

SUNCOAST COALING TOWER

Dump pit

Though the base can be made from gluing styrene strips together it was easier to make the bases out of basswood.

The grating is 7 mesh yarn plastic canvas such as Yarnology 77 3515 that was cut to fit the space between the rails allowing room for truck flanges to run smoothly over the inside of the outer rails. To raise the grating to a proper height shims are needed. One can use black styrene plastic or card board as shown.

The grating can also be glued on top of the track pins if you don't want to use shims.

Whether one uses Atlas O, Ross or Gargraves track there are track pins (plastic or metal) that the grating must fit over so the shim on the two inside positions is cut to fit between these pins.

SUNCOAST COALING TOWER

Dump pit

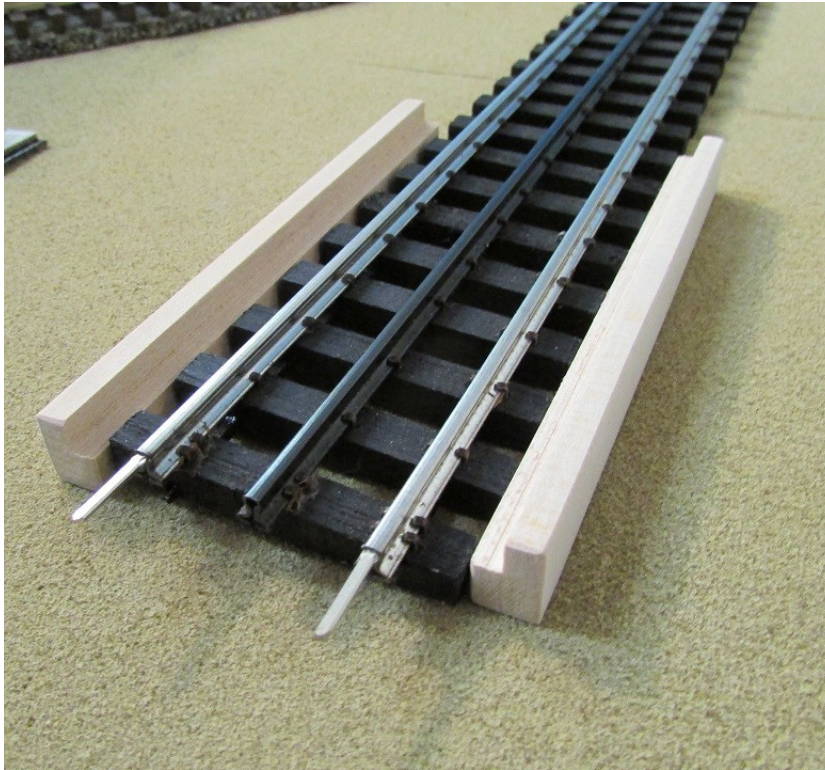

Bottom of grating for
two outside positions

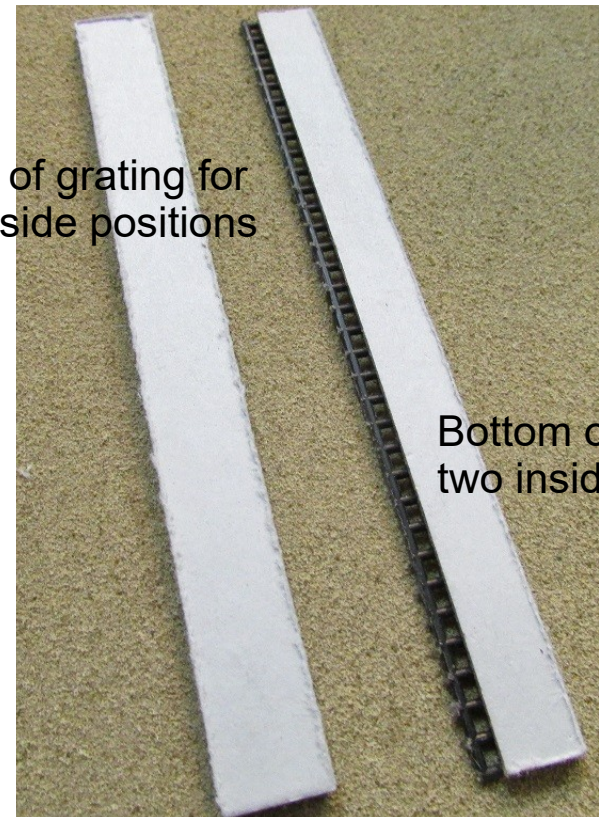

Bottom of grating for
two inside positions

Paint wood concrete color. Paint grating black.

SUNCOAST COALING TOWER

Paint

The formula for 'concrete' is:

Base coat flat black ~80% coverage

Second coat red oxide ~80%

Third coat dark gray

Final coat light gray

to the point where you like the color.

This 'formula' is no where near precise.



SUNCOAST COALING TOWER

Paint



Flat Black base coat



Red Oxide over coat

SUNCOAST COALING TOWER

Paint



Dark Gray over coat



Light Gray final coat